

MITEL

Solutions Alliance (MSA)



General Information Guide
Release 6.0



NOTICE

The information contained in this document is believed to be accurate in all respects but is not warranted by Mitel Networks™ Corporation (MITEL®). The information is subject to change without notice and should not be construed in any way as a commitment by Mitel or any of its affiliates or subsidiaries. Mitel and its affiliates and subsidiaries assume no responsibility for any errors or omissions in this document. Revisions of this document or new editions of it may be issued to incorporate such changes.

No part of this document can be reproduced or transmitted in any form or by any means - electronic or mechanical - for any purpose without written permission from Mitel Networks Corporation.

TRADEMARKS

Mitel, SX-200, SX-2000, 3300 ICP, 5000 CP, Superset, Superconsole 1000, MiTAI are trademarks of Mitel Networks Corporation.

Other product names mentioned in this document may be trademarks of their respective companies, including Mitel Networks Corporation, and are hereby acknowledged.

This document and the products mentioned within are supported by the [Mitel Solutions Alliance \(MSA\) Developers and Integrators Program](http://www.mitel.com/DocController?documentId=9971) (<http://www.mitel.com/DocController?documentId=9971>).

For Developer Support (requires Technical Support ID), contact the MSA program at: MSASupport@mitel.com

Mitel Solutions Alliance General Information Guide
Release 6.0
December 2011

® ™ Trademark of Mitel Networks Corporation
© Copyright 2011, Mitel Networks Corporation
All rights reserved

| | |
|---|-----------|
| ABOUT THIS DOCUMENT | 1 |
| MSA PROGRAM FOR DEVELOPERS | 1 |
| Overview | 1 |
| Which Mitel Suppliers Should Consider Joining MSA?..... | 2 |
| MSA Membership Benefits to Mitel Vendor Partners and Solution Providers | 2 |
| How Does MSA Help Mitel End-Customers? | 3 |
| MSA Membership Options..... | 3 |
| How to Join MSA | 7 |
| APPLICATION DEVELOPMENT AND INTEGRATION | 8 |
| The Application Development Process | 8 |
| Planning | 8 |
| Development | 8 |
| Interoperability Testing & Certification | 9 |
| Roll Out..... | 10 |
| Support..... | 10 |
| MITEL DEVELOPMENT ENVIRONMENTS | 10 |
| Mitel 3300 ICP | 10 |
| 3300 ICP Application Development | 11 |
| Mitel SX-200 ICP | 13 |
| SX-200 ICP Application Development | 13 |
| Mitel 5000 Communications Platform | 14 |
| Mitel 5000 Application Development..... | 14 |
| Inter-Tel Axxess Converged Communications Platform | 14 |
| MSA ADVANCED LEVEL INTERFACES | 15 |
| API Licensing..... | 15 |
| Software Development Kit (SDK) | 16 |
| MiTAI | 16 |
| MiTAI and 3300 ICP Resiliency | 17 |
| MiTAI and MiAUDIO..... | 18 |
| MiAUDIO..... | 18 |
| Supported Environments..... | 19 |

| | |
|--|-----------|
| Secure Recording Connector | 19 |
| System OAI..... | 20 |
| Customer Service Manager (CSM) SDK | 21 |
| MSA BASIC LEVEL INTERFACES..... | 21 |
| Data Interfaces for the 3300 ICP and SX-200 ICP Platforms | 21 |
| SMDR | 21 |
| SNMP..... | 22 |
| Property Management System | 23 |
| Automatic Call Distribution Real Time Events | 24 |
| HTML Toolkit..... | 25 |
| SIP | 26 |
| Axxess/5000 CP Data Interfaces..... | 27 |
| SMDR | 27 |
| Other MSA Interfaces | 28 |
| Live Business Gateway | 28 |
| Mitel Contact Center CTI Developer Toolkit..... | 29 |
| Unified Communicator Advanced (UCA) Software Development Kit | 30 |
| TAPI Integration..... | 30 |
| IMAP/SMTP | 31 |
| DOCUMENTATION INDEX | 31 |
| Accessing the MSA Web Portal on Mitel OnLine..... | 32 |
| Accessing the Mitel Knowledge Base..... | 32 |
| MSA Interfaces Documentation | 33 |
| Advanced Interfaces Documentation..... | 34 |
| Basic Interfaces Documentation | 35 |
| Other Interfaces Documentation..... | 35 |
| Controller/PBX Documentation..... | 35 |
| Other Documentation..... | 37 |
| LIST OF ACRONYMS..... | 38 |

About this Document

Welcome to the Mitel® Solutions Alliance (MSA). MSA is a comprehensive program enabling a wide range of Third-Party Partners (3PPs) to successfully create products and services that integrate and/or interoperate with Mitel's core business communications portfolio, and to create awareness of these products and services among Mitel retail channel sales partners and end-customers.

To extend the many telephony devices and applications that Mitel markets, we provide a collection of interfaces. We invite 3PPs to develop their own applications to interact with these Mitel products. In this way, all of our customers benefit from the efforts of a large base of software development teams. We also encourage our end customers to customize their Mitel products.

This guide is intended for application developers, solution and service providers, end customers, resellers, sales and marketing teams, and anyone interested in the development of applications or services that interface with Mitel communications controller/PBXs, including the 3300 ICP, the 5000 CP, and the SX-200® ICP.

Readers of this document will obtain general information about all of the interfaces available from Mitel. For more detailed information about each interface, refer to the individual documents referenced in each section and in the Documentation Index on page 31.

This guide provides an overview of the MSA Program for prospective MSA members, covering the following topics:

- General Information about the MSA Program (see below)
- The Application Development Process (see page 8)
- Mitel Development Environments (see page 10)
- MSA Advanced Level Interfaces (see page 15)
- MSA Basic Level Interfaces (see page 21)
- Other MSA Interfaces (see page 28)
- Documentation Index (see page 31)

MSA Program for Developers

Overview

The Mitel Solutions Alliance (MSA) offers 3PP vendor partners, solution and service providers (Mitel Suppliers), and Mitel end-customers access to software development tool kits and related support services for enabling integration with our award-winning range of IP communication devices. Mitel Suppliers may join the program at one of several levels of MSA Commercial Developer membership, while Mitel end customers may join at one of two MSA Corporate Developer membership levels. MSA Commercial members are listed in our online MSA Global Solutions Catalogue (GSC), as are their products that meet minimum interoperability requirements.

Which Mitel Suppliers Should Consider Joining MSA?

Maintaining close ongoing and mutually beneficial relationships with our 3PP vendor partners and service providers is an essential element of Mitel's corporate strategy for growth and success. A primary purpose of the MSA program is to facilitate expansion of our 3PP product and application portfolio or ecology through MSA membership, specifically to enhance the value of core Mitel business communication products for our customers.

These 3PP vendors and providers include:

- **Commercial Off-The-Shelf (COTS) Product and Solution Vendors:** Partners using Mitel APIs and interfaces to develop their products, including integrations between partner products and Mitel products.
- **Interoperability Partners:** Partners using Mitel interfaces, protocol documentation and test resources to test interoperability between their products and Mitel products, e.g., for SIP interoperability.
- **VARs, Custom Solutions Providers and Systems Integrators:** Partners using Mitel APIs and interfaces to develop custom applications, implement Communications Enabled Business Processes (CEBP), and carry out systems integration for end-customers. This category includes dedicated service companies as well as those channel sales partners that do integration work.
- **Strategic/OEM Partners:** These relationships are managed through the Mitel Strategic Partners group. MSA supports these efforts by facilitating the necessary API fulfillment and developer support to ensure strategic and OEM relationships are productive and efficient.

MSA Membership Benefits to Mitel Vendor Partners and Solution Providers

To achieve the goal of a rich ecology, MSA membership offers a structured program and suite of tools and services for 3PPs and developers working with Mitel, including:

- **Developer Tools:** Application and Programming Interfaces (APIs), protocols, lab systems, toolkits and documentation, to enable rapid development and integration of products and services with the range of Mitel PBX and desktop products.
- **Developer Support:** Centralized access with incident tracking, to maximize the value of APIs and speed development.
- **Access to Interoperability Test Resources and Certification:** To lower the cost-of-entry and speed access to the Mitel channel, improve 3PP product quality, and encourage customer confidence in 3PP offerings.
- **Technical and Market Intelligence:** On Mitel's product portfolio and the market segments we serve.
- **Marketing Support:** Via the Mitel Global Solutions Catalog (GSC), other web content, and regular reseller communication to advertise available products and services to Mitel's channel sales partners and end users.
- **Return On Investment:** Partners investing more substantially in the Mitel channel will reap better rewards through MSA than those who meet minimum requirements. Commitment to the Mitel sales channel will be apparent in the information provided through the GSC, in terms of product certification levels, partnership levels, and pre-sales support tools. Partners who groom their product features and pricing strategies to complement Mitel products will accrue returns beyond those seen by partners utilizing our channel as part of a more generalized (non-Mitel-specific) marketing strategy.

The MSA program membership structure, with corresponding features, benefits, and benchmarks, also provides a roadmap for Mitel 3PPs to see the possibilities for growth and increased channel penetration and business success with Mitel over time.

How Does MSA Help Mitel End-Customers?

MSA is a key resource for prospective and existing Mitel end customer Buyers, offering these benefits:

- **Information:** A place to research the Mitel ecology of compatible and approved 3PP products and solutions, in support of pre-sale due diligence (for example, to confirm Mitel support for a customer's existing or proposed product and solution infrastructure), as well as a means to help existing end-customers meet new business requirements with vetted 3PPs and confirmed interoperable products. This information is assembled and managed by MSA, but is accessible to anyone (regardless of MSA membership) through the Global Solutions Catalog (GSC).
- **Developer Tools and Documentation:** To enable rapid in-house custom application development, and integration of internal business processes and applications, with their Mitel PBX and desktop products. These materials are available to Mitel end-customers that join MSA.
- **Developer Support:** To minimize and speed in-house integration efforts, and help ensure the resulting work performs properly and reliably. Support is available to Mitel end-customers that join MSA.

MSA Membership Options

Mitel's MSA program recognizes that every member has crafted their own business strategy, and this strategy must fit with the program. That is why MSA members need options: options that provide for simple product interoperability issues, options that enable product resale, and options that provide for the middle ground.

MSA membership is organized into three primary categories as outlined below. All MSA partners receive the benefits associated with the MSA Developer program level. MSA Gold Preferred and MSA Platinum Preferred (MPP) memberships involve a closer relationship with Mitel and confer additional benefits, and these Preferred Partner options can be reviewed with an MSA Program Manager after the initial MSA Developer membership is approved.

MSA Developer Partners

This level is the entry point into the MSA program for all members, enabling both the Mitel partner ecology as well as end-customer integration projects. MSA Developer Membership features:

- Minimal partner or product vetting.
- Access to APIs, technical documentation, training, and Developer Support.
- MSA-on-MOL (Mitel OnLine internal web portal) access credentials
- Access to integration/interoperability test resources.
- Steep discounts on Mitel core products purchased for in-house development/lab/test purposes, and the ability to manage these products via the Mitel AMC licensing portal.
- Global Solutions Catalog listing (subject to appropriate test completion).

Within the MSA Developer Level, membership options are further organized as follows:

- **MSA Corporate Developer Level:** For End-Customers performing in-house integration projects (not for resale).
- **MSA Commercial Developer Level:** For vendors and other partners selling products, solutions or services directly to Mitel resellers and End-Customers.

Both End-Customers and Suppliers can join the program at either the “Basic” or “Advanced” Developer level, depending upon the type of APIs and interfaces required.

- **Developer Basic:** For members seeking basic interoperability with Mitel products, using Mitel’s standard protocol interfaces, or simply seeking to use information generated by the Mitel products. The MSA program includes a cost- effective and responsive ‘Basic’ membership option tailored specifically for these members.
 - This option serves integration needs that do not require our advanced API suite (MiTAI, MiAUDIO, and SRC for the 3300 ICP or OAI for the 5000 CP). Interfaces and documentation included with this partnership level includes Data Interfaces (SMDR (for both 3300 and 5000 platform), ACD, Hotel/Motel Logs, Property Management System, Maintenance/Software Logs, and SNMP), SIP, and the HTML toolkit for the 3300 platform.
- **Developer Advanced:** For members seeking to leverage Mitel’s advanced programming and call control interfaces, in order to deliver complementary products that present an integrated customer experience. MSA serves these members with an ‘Advanced’ membership option, which offers more support, more documentation, and access to a complete suite of Mitel programming interfaces.

This option serves the full range of integration requirements via our Developer level APIs or protocols. Interfaces included at this level include all the Basic level interfaces and a rich set of developer tools that includes:

- Universal Software Development Kit (SDK), which contains client libraries for our cornerstone MiTAI and MiAUDIO interfaces (for the 3300 platform).
- OAI and CSM (formerly CCS) SDKs (for the 5000 CP).
- Secure Recording Connector (SRC).

An overview of the interfaces available by MSA Member level is shown in Table 1 below:

Table 1. MSA API Portfolio Summary by Member Level

| | | | |
|----------------------------|-----------------|--|---|
| Preferred | | Advanced API's | |
| | | <ul style="list-style-type: none"> • MiTAI • MiAudio • OAI | <ul style="list-style-type: none"> • Secure Recording Connector • CSM (CCS/CV) |
| Developer | Advanced | | |
| | Basic | Basic API's | |
| | | <ul style="list-style-type: none"> • SMDR (2 flavors) • ACD Real-time events • SW/MTCE Logs • Hotel / Motel Logs | <ul style="list-style-type: none"> • SNMP • HTML Toolkit • SIP |
| Unrestricted Access | | Open API's | |
| | | <ul style="list-style-type: none"> • IMAP • Call Director | <ul style="list-style-type: none"> • HTML Toolkit (no support) • SIP (no support) |

- **MSA Gold Preferred Partners:** For vendors and other partners whose products, solutions or services are resold by Mitel. They require sponsorship by a Mitel resale organization (e.g., CommSource), and receive all Developer Partner benefits plus

additional benefits including greater channel visibility. In addition, because solutions from these partners are sold and supported by Mitel into our channel sales organizations, additional business and technical requirements apply, as determined by the internal Mitel sponsor.

- MSA Platinum Preferred (MPP) Partners:** Members at this level bring strategic or specialized value to Mitel. They require sponsorship by one or more Mitel stakeholders, and receive all Developer Partner benefits plus additional benefits including extensive collaboration and go-to-market support from Mitel Product Line Management (PLM).

Table 2 (below) shows a comparison of features and benefits for each of the MSA levels.

Table 2. MSA Program Level Features & Benefits Summary

| Category | Feature | Type | Developer Corporate | Developer Corporate | Developer Commercial | Developer Commercial | Gold Preferred Commercial | Platinum Preferred Commercial |
|------------|---|-------|---------------------|---------------------|----------------------|----------------------|---------------------------|-------------------------------|
| | | Level | Basic | Advanced | Basic | Advanced | Advanced | Advanced |
| Membership | Initial and Annual Renewal Fee | | \$1000 ¹ | \$2000 ¹ | \$1000 | \$3000 | \$3000 | Waived |
| | Mitel Sponsorship & Approvals Required | | MSA Only | MSA Only | MSA Only | MSA Only | MSA & Resale Org | MSA & PLM |
| | Type of Partner Member | | End Customers | End Customers | VARs/Vendors | VARs/Vendors | Sponsored VARs/Vendors | Strategic VARs/Vendors |
| | Membership Term | | 1 year ¹ | 1 year ¹ | 1 year | 1 year | 1 year | 1 year |
| Technology | Basic API and Documentation Package | | Yes ² | Yes ² | Yes ² | Yes ² | Yes ² | Yes ² |
| | Advanced API and Documentation Package | | No ² | Yes ² | No ² | Yes ² | Yes ² | Yes ² |
| | License Resale/Redistribution | | No | No | Yes ³ | Yes ³ | Yes ³ | Yes ³ |
| | Development/Lab System Equipment Discount | | No | No | Yes | Yes | Yes | Yes |
| Marketing | Global Solutions Catalog Listing | | No | No | Yes ⁴ | Yes ⁴ | Yes ⁴ | Yes ⁴ |
| | Corporate Logo Usage | | No | No | Yes | Yes | Yes | Yes |
| | Self Assessment Test (SAT) program access | | No | No | Yes | Yes | Yes | Yes |
| | Mitel-Compatible Test (MCT) Logo Usage | | No | No | Yes ⁵ | Yes ⁵ | N/A | N/A |
| | Mitel-Approved Test (MAT) Logo Usage | | No | No | No | No | Yes ⁵ | Yes ⁵ |
| | GSC Test Status Annotation (SAT/MCT/MAT) | | No | No | Yes ⁴ | Yes ⁴ | Yes ⁴ | Yes ⁴ |
| | Go-to-Market & Channel Strategy Development | | No | No | No | No | Yes | Yes |
| | Marcomm & Preferred MOL | | No | No | No | No | Yes | Yes |

Mitel Solutions Alliance General Information Guide

| Category | Feature | Type | Developer Corporate | Developer Corporate | Developer Commercial | Developer Commercial | Gold Preferred Commercial | Platinum Preferred Commercial |
|------------|--|-------|---------------------|---------------------|----------------------|----------------------|---------------------------|-------------------------------|
| | | Level | Basic | Advanced | Basic | Advanced | Advanced | Advanced |
| | Content | | | | | | | |
| | BPC/Forum Exhibit Option | No | No | No | No | No | Yes | Yes |
| | Gold Package | No | No | No | No | No | Yes | Yes |
| | Platinum Package | No | No | No | No | No | No | Yes |
| | Mitel Price Book & Sales Workbench Listing | No | No | No | No | No | Limited | Yes |
| Support | Priority Access to Interop Certification Program | No | No | No | No | No | Yes | Yes |
| | Developer Support Credits (DSC) | 1 | 3 | 1 | 5 | 5 | 5 | 5 |
| | New Release Notifications | Yes | Yes | Yes | Yes | Yes | Yes | Yes |
| | Additional DSCs (each) | \$250 | \$250 | \$250 | \$250 | \$250 | \$250 | \$250 |
| Web Portal | Access to MSA Portal at MOL | Yes | Yes | Yes | Yes | Yes | Yes | Yes |
| | Technical Product Bulletins (via MOL) | Yes | Yes | Yes | Yes | Yes | Yes | Yes |
| | Downloadable API SW & Updates | Yes | Yes | Yes | Yes | Yes | Yes | Yes |
| | Downloadable Platform SW Updates/Upgrades | No | No | Yes | Yes | Yes | Yes | Yes |

Notes:

1. Renewal fees waived for Corporate Members who maintain uninterrupted coverage under approved TotalSolution or SWA offering.
2. See separate API table for itemized list of included APIs and documentation. License and/or royalty fees may apply.
3. Licensing is vendor product-specific and maybe defined in terms of specific geographic territories and/or markets.
4. Product listings approved only after completion of SAT and/or MCT. All Commercial members can get a base listing.
5. Logos authorized for use only upon appropriate test result approval by MSA & Mitel Interop groups.

Key: MCT = Mitel-Compatible Test MAT = Mitel-Approved Test SAT = Self-Assessment Test GSC = Global Solutions Catalog

How to Join MSA

Joining the MSA Program is a simple four-step process:

1. Program Review and Online Application
2. All companies interested in joining the MSA Program must submit an online application for one of the following levels:
 - MSA Corporate Developer (Basic APIs)
 - MSA Corporate Developer (Advanced APIs)
 - MSA Commercial Developer (Basic APIs)
 - MSA Commercial Developer (Advanced APIs)

Partners planning to supply multiple products/solutions/services to the Mitel channel require a membership discussion with an MSA Program Manager. All such products/solutions/services should be identified in the Product Information section of the application form.

The online application process generates an automated confirmation email. After you apply online you'll need to follow through with the confirmation in order for MSA to see your application (i.e., responding in accordance with the instructions given in the confirmation email). Note that these automated confirmations sometimes end up in the recipient's spam folder, so we recommend checking there if you don't get the confirmation email within a few hours of submitting your application. We also recommend that you separately send us an email to MSAInfo@mitel.com after you've completed the online application, so we can follow up with you if we don't see your response to the confirmation.

3. Application Review. Within 5 days, an MSA Program Manager will review the application and send out the formal Membership Agreement forms or, if necessary, you will be contacted for a follow-up discussion.
4. Application Processing. After the ratified Membership Agreement forms are returned to MSA, you will be provided with instructions for making the membership payment. After payment has been received, the membership enrollment process is complete.
5. Membership Begins. You can now begin to enjoy the benefits of the MSA program. You will receive a welcome email with information about your MOL logon credentials, obtaining Developer Support, and other MSA membership details.

To apply for a MSA membership online:

1. Visit the Mitel Partners & Resellers MSA web site at <http://www.mitel.com/msa>.
2. Click the **Join MSA Now** link.
3. Complete and submit the online application.
4. Respond to the email acknowledgment.

After you become a member, the MSA web site at Mitel Online (MOL) provides instructions for downloading MSA software, and obtaining up-to-date information, documentation, sample code, and software fixes related to MSA software.

Application Development and Integration

The following sections of this document are designed to get you started with the development and integration process.

The Application Development Process

The application development process consists of five stages:

Planning

- Consider the features and functionality your application requires.
- Consider any restrictions associated with your targeted Mitel platform.
- Research the Mitel interfaces using the documents listed in the [Documentation Index](#) on page 31 and select the one that best meets your needs.
- Research our Mitel partner product categories, how your product will fit, and the minimal requirements we place on products with the matching categories. In many cases, MSA can provide you with modular sets of integration test plans to facilitate full test coverage, and ultimately to facilitate high product quality.¹
- Plan your test environment. Depending on which Mitel platform you target, you will have different options. We offer remote access to some of our Mitel platforms, and also discounted platform purchase options that facilitate low cost testing within your facility.
- Determine what Mitel channels, programs, countries, or other variables affect your product manager's strategy, and consult with MSA to get prior approval for your product plans. This is typically a formality, but we do screen products that compete with our own core products.

Development

- Use the appropriate Installation and Maintenance Guide to install your selected interface.
- Use the appropriate Developer Guide for reference.
- Complete the appropriate Mitel training programs. Mandatory training programs are offered as on-line tutorials², while other training may involve travel to our facilities.
- Install and configure the Mitel platform and supporting products necessary for your testing environment.
- Create and unit test your application.
- Create interoperability test plans based on Mitel's minimum requirements, your product's feature set, and the test report that you will submit to Mitel.

¹ Before your product is listed within the MSA Global Solutions Catalog, we review your test report and format it for publication as reference material for our channel. This review process checks that your product testing declares that your product meets our minimum requirements.

² Our support staff cannot help you unless these training programs are completed.

Interoperability Testing & Certification³

MSA members and their products are listed and categorized within the Mitel Global Solutions Catalog (GSC). The GSC listing provides both company and contact information, and is intended to communicate a clear picture of 3PP product description and Mitel testing / interoperability status through useful search features and interfaces.

Test guidelines, resources, and requirements are essential in helping ensure that 3PP products work reliably for our end customers and minimize Mitel support burdens. The product classification process is modeled as follows:

- Products step through the test program, achieving “Levels”
- Levels are communicated to channel sales partners with a “Logo”
- The GSC lists products along with appropriate logo, as well as partner membership status (MSA Developer; MSA Gold Preferred; MSA Platinum Preferred)
- A product ‘Fact Sheet’ is published (e.g., versions, geographies, languages)

Key MSA integration / interoperability test and certification program features and requirements are summarized in the table below:

Table 3. MSA Member Test & Certification Levels

| | Interoperability Tested by | Business Case Sponsor | Supported by | Sold by |
|----------------------------------|----------------------------|-----------------------|--------------|---------|
| Global Solutions Catalog Listing | Partner | No | Partner | Partner |
| Mitel Compatible | Mitel | No | Partner | Partner |
| Mitel Approved | Mitel | Yes | Partner | Partner |
| | | | Mitel | Mitel |

Key steps in the MSA integration / interoperability test and certification process can be summarized as follows. See also “Interop Certification - MSA Developers and SIP Service Providers” overview document – available for download from the MSA-on-MOL web portal:

- Provide self-assessment test plans to facilitate rapid testing and deployment.
- Optionally, work with MSA or other internal Mitel sponsor to submit products to Mitel for formal execution of interoperability tests, carefully documenting configuration requirements, limitations, product version numbers, and pass/fail results. Mitel certification testing is required for products resold by Mitel.
- Assess performance and capacity for publication to our channel.
- Complete Mitel’s product test report, and attach any traces or recordings necessary to support our MSA review process.
- Optimally, work with a Mitel customer directly, to deploy your product in a ‘beta’ site.

³ See also “Interop Certification - MSA Developers and SIP Service Providers” overview document – available for download from the MSA-on-MOL web portal.

Roll Out

- Submit test report to MSA program, requesting that your product be listed in our Global Solutions Catalog.
- Complete any product-specific contractual agreements.
- Complete an MSA 'Fact Sheet' for your product. This Fact Sheet is your voice to our channel, and is the basis of your product descriptions, our product search features, channel compatibility information, and sales/support contact information.

Support

- Work with our retail channel sales partners and their end customers to complete order fulfillment, installation, and configuration.
- Work with our retail channel sales partners to offer end customer training, if appropriate.
- Take responsibility for the interoperation and support of your product and the Mitel product. Your support staff may call upon our Mitel support staff according to the features of your MSA partnership agreement.
- Watch for MSA notifications of API changes, version upgrades, or problem reports.
- Submit product Fact Sheet errata/addendums when your product software versions change. MSA will use this information to keep the Global Solutions Catalog up to date.

Mitel Development Environments

Mitel markets a large array of products. This guide provides an overview of Mitel's four communications platforms from an application developer's or service provider's point of view. These are:

- [Mitel 3300 ICP](#) (see page 10)
- [Mitel SX-200 ICP](#) (see page 13)
- [Mitel 5000 Communications Platform](#) (see page 14)
- [Inter-Tel Axxess Converged Communications Platform](#) (see page 14)

Detailed information about Mitel controllers is available at MOL. See the [Documentation Index](#) on page 31.

Mitel 3300 ICP

Mitel Communications Director (MCD) software integrates the analog Private Branch Exchange (PBX) world and digital Voice over IP (VoIP) world. It is deployed on the Mitel 3300 ICP hardware, composed of a main controller, optional digital network service units (NSU), and analog service units (ASU). These devices manage a rich portfolio of peripherals and applications including Mitel IP telephones, wireless IP telephones, and digital telephones. Applications include voice mail, speech-enabled auto attendant, and unified messaging, as well as a full line of call center options, all easily managed by web-based applications. The system also supports a wide range of analog and digital trunks for connection to the Public Switched Telephone Network (PSTN), and for connecting multiple sites or systems together. In addition, the 3300 ICP with MCD software provides IP networking, enabling multiple sites to be connected via a LAN/WAN infrastructure, and offers:

- Robust call control services, functionality and applications associated with a traditional PBX, including multiple levels of call forwarding, message waiting, advisory messages, conference calling, account codes, call barring, least cost routing, and night service.

- Integrated applications and a converged infrastructure that delivers lower total cost of ownership.
- Operability on a stand-alone basis and the ability to cluster multiple systems together over IP or Time Division Multiplexed (TDM)-based infrastructures.
- Support for thousands of users, whether co-located or geographically dispersed.
- Ability to manage clustered systems as a single network from any authorized location.

3300 ICP Application Development

Application developers can access a wide array of interfaces to tap into the 3300 ICP and its supported devices and services. These include:

- Advanced-level interfaces such as the Software Development Kit (SDK) (including MiTAI and MiAUDIO), and Secure Recording Connector (SRC).
- Basic-level interfaces such as ACD, SMDR, SNMP, PMS, HTML Toolkit, and SIP.
- Through these APIs, the following ICP-managed devices are available to application developers:
 - Mitel 5xxx-series IP Phones (except those model numbers ending with '1', '5', or '7') and Conference Units
 - Mitel IP Paging Unit
 - Symbol MiNET Wireless Phone
 - Symbol NetVision Phone
 - Spectrum24 Access Points
 - Mitel SUPERSET® 4000-series Telephones
 - SUPERCONSOLE 1000®
 - Analog telephones

 **Note:** Not all devices are supported by each Mitel API/interface. See API-specific developer documentation for API-specific device support.

Figure 1 on page 12 represents the architecture of a converged 3300 ICP environment:

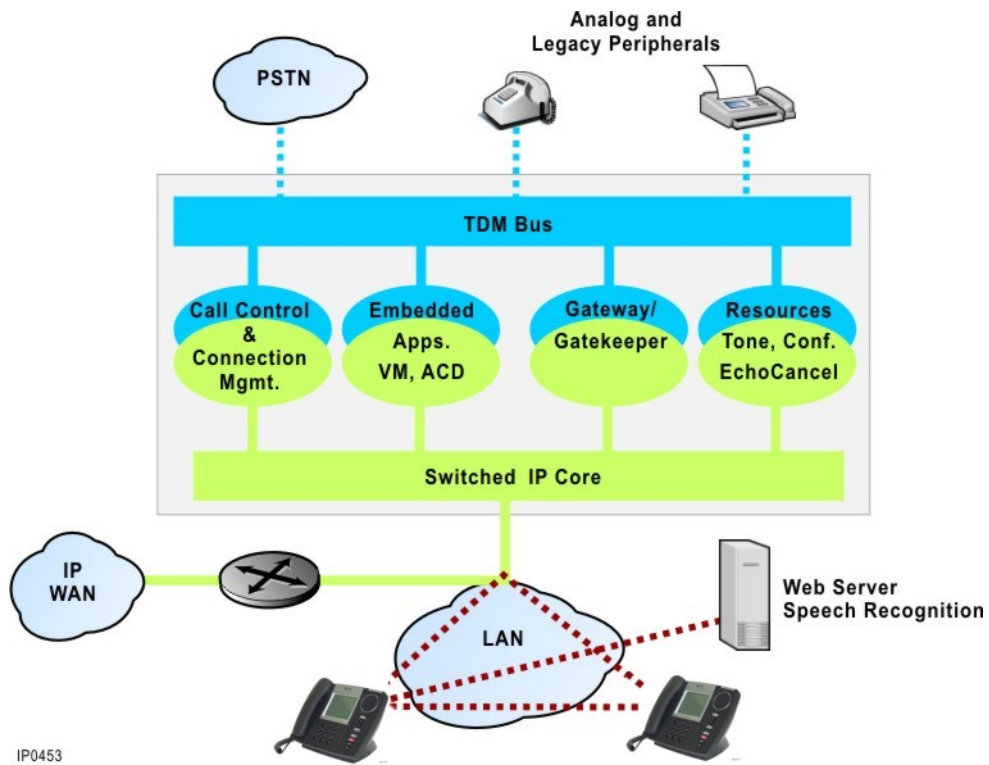

Figure 1. Converged 3300 ICP Environment

More information about Mitel Communications Director is available in the Mitel Communications Director General Information Guide available at Mitel OnLine. See the [Documentation Index](#) on page 31.

Mitel SX-200 ICP

Tailored for small enterprise, the SX-200 ICP offers VoIP, LS/CLASS, ONS/CLASS and DNIC solutions. It is composed of a main controller, optional digital network service unit (NSU) and optional analog services unit (ASU). These devices manage a rich portfolio of peripherals and applications including Mitel IP phones and digital phones. Applications include voice mail, speech-enabled auto attendant, and unified messaging, as well as a full line of call center options. The system also supports a wide range of analog and digital trunks for connection to the Public Switched Telephone Network (PSTN), and for connecting multiple sites or systems. The SX-200 ICP also provides IP networking, enabling multiple sites to be connected via a LAN or WAN infrastructure. The SX-200 ICP offers:

- Robust call control services, functionality and applications associated with a traditional PBX, including multiple levels of call forwarding, message waiting, advisory messages, conference calling, account codes, call barring, least cost routing, and night service.
- Integrated applications and a converged infrastructure.
- Operability on a stand-alone basis and the ability to cluster multiple systems together over IP or Time Division Multiplexed (TDM)-based infrastructures.
- Support for hundreds of users, whether co-located or geographically dispersed.
- Ability to manage clustered systems as a single network from any authorized location.

SX-200 ICP Application Development

Application developers can access many APIs to tap into the SX-200 ICP and its devices and services. These APIs include:

- Development interfaces such as MiTAI.
- Data interfaces such as ACD, SMDR, and PMS.

Through these APIs, the following ICP-managed devices are available to application developers:

- Mitel 5000-series IP phones and Conference Units (except the 5235)
- Mitel IP Paging Unit
- Symbol NetVision Phone
- Spectrum24 Access Points
- Mitel SUPERSET 4000-series Telephones
- SUPERCONSOLE 1000
- Analog telephones

 **Note:** Not all devices are supported by each Mitel API/interface. See API-specific developer documentation for API-specific device support.

More information about the SX-200 ICP is available in the SX-200 ICP General Information Guide available at Mitel OnLine. See the Documentation Index on page 31.

Mitel 5000 Communications Platform

The Mitel 5000 CP enables organizations to blend their voice system into their data network, creating a cost-effective, efficient communications environment. The 5000 CP offers an IP-centric communications platform, which allows businesses to network geographically-dispersed associates and locations, whether they're connecting offices and applications together over a data network, or deploying IP endpoints to on-site employees.

5000 CP solutions support multiple software applications, resulting in operational efficiencies and a foundation for a more flexible infrastructure. Software has been built on a platform that efficiently combines the best of both data network and TDM (switching) architectures. It provides a complete solution for pure IP deployments.

The 5000 CP suite includes applications that enhance value delivered to the end customer. These applications provide opportunities for integration, as well as the core 5000 servers.

Mitel 5000 Application Development

Application developers can access many APIs to tap into the 5000 CP and its devices and applications such as:

- Development interfaces such as OAI
- Data interfaces such as SMDR
- Messaging interfaces such as IMAP
- Network interface such as CT Gateway

The following is a list of applications that offer integration interfaces:

- 5000 Network Servers
- Contact Center Suite Customer Service Manager (CSM)
- Unified Messaging/Open Standards Edition

Inter-Tel Axxess Converged Communications Platform

Axxess is a highly flexible, scalable and integrated infrastructure, delivering a feature-rich solution that is migration-friendly and Internet-ready. Our converged system combines analog, digital, wireless and Internet Protocol (IP) into a single platform - giving your customers the choice of deploying traditional, IP telephony or a combination of both when and where it's right for their organization. Whether an enterprise needs to connect several phones in an office, hundreds of phones in a building or on a campus, remote and telecommuting associates, or even geographically dispersed offices, the Axxess Suite unifies communications.

The Axxess Suite and the 5000 CP solutions share the same set of application interfaces. Partners and customers who develop for one suite will generally not face portability issues when they choose to develop for the other suite.

As the 5000 CP continues to evolve, it will maintain a superset of Axxess functionality.

MSA Advanced Level Interfaces

Mitel is a leader in providing one of the most varied and robust portfolios of application toolkits and developer systems. Mitel’s portfolio allows companies to develop and rapidly integrate private applications to Mitel communication platforms and voice-enabled technologies.

MSA advanced level interfaces include:

| 3300 ICP and SX-200 ICP Platforms | 5000 CP Platform |
|--|--|
| <ul style="list-style-type: none"> • Software Development Kit (SDK) | <ul style="list-style-type: none"> • OAI Toolkit |
| <ul style="list-style-type: none"> • Secure Recording Connector (SRC) | <ul style="list-style-type: none"> • Customer Service Manager (CSM) SDK – formerly Contact Center Suite |

API Licensing

Some Mitel APIs available through MSA require purchased licenses and/or royalties. The licensing and other fee considerations are defined in the MSA membership agreements, and are summarized in detail as follows:

- All Mitel developer partners who wish to do any of the following must maintain an active membership in MSA at the Commercial Developer Advanced level:
 - Access Mitel proprietary APIs (e.g., MiTAI; OAI; SRC; CCS/CSM; etc.)
 - Sell/deploy applications enabled with Mitel APIs
 - Obtain Mitel Developer Support
 - Access technical resources via the MSA-on-MOL web portal
 - Maintain their company and product(s) listing in the Mitel Global Solutions Catalog (GSC)
- All MSA Commercial Developer Advanced members must file quarterly API license/royalty reports to MSAInfo@mitel.com, documenting all new field deployments of MiTAI and/or MiAUDIO-enabled applications. MSA then invoices the MSA member for MiTAI/MiAUDIO licensing fees incurred, in accordance with member’s royalty report.
- With regard to license and royalty calculations: The MiTAI Desktop Edition port license (USD\$15/seat) permits a single MiTAI client port connection to the Mitel switch from a single client PC, and the MiTAI Server Edition license (USD\$500/server) permits an unlimited number of port connections to one or more Mitel switches from a single PC. For example, if a single customer site has two servers running a member’s MiTAI-enabled application, each of which is connecting to one or more 3300 switches, the member would owe a one-time MiTAI Server Edition royalty of 2 x USD\$500 = USD\$1000.
- Unless otherwise agreed to in writing with Mitel, Members using the MiTAI API are assumed to be licensing via the MiTAI Server Edition model.
- Members who wish to use the Secure Recording Connector (SRC) API require one MiTAI Edition license per SRC-enabled PC server.
- MiTAI and MiAUDIO are the only APIs offered through MSA for which royalty obligations are incurred by the MSA member and reported via the Quarterly Report. Other Mitel APIs or interfaces (e.g., OAI; SRC; CCS/CSM; SIP, etc.) are licensed and paid for by the end-customer, so the member's only fees for using these latter APIs/interfaces are the annual MSA membership fee.

- All API licensing fees and obligations (whether paid by the MSA member or end-customer) are one-time (non-recurring).

Software Development Kit (SDK)

The MSA Software Development Kit (SDK) is a set of software, testing tools, and documentation that provides developers what they need to effectively develop applications for the 3300 ICP and SX-200 ICP Platforms.

The SDK application contains the following software options:

- **MiTAI:** Enables switch-to-application server communication for multiple switches. This software interface applies to the Mitel 3300 ICP and the Mitel SX-200 ICP.
- **MiAUDIO:** Enables applications to process voice on multiple Mitel hard- or softphones (3300 ICP only).

The SDK offers the following troubleshooting tools:

- **MiTAI Browser Tool** (and mtaix Tool for Linux): Used to ensure the connection is functioning properly, to make function calls and to view events from the API.
- **MiTAI Server Logger Tool:** Used to connect to the 3300 ICP and download log files, and to capture all 3300 MiTAI server incoming and outgoing messages for debugging purposes.
- **MiTAI Client Logger Tool:** Used to access MiTAI application information, to collect MiTAI API information in a log file, and to capture MiTAI client data about incoming and outgoing messages for debugging.
- **MiAUDIO Test Tool:** Used to verify that MiAUDIO has been correctly installed and that all connections allow proper communication between the MiAUDIO application and the 3300 ICP.

MiTAI

Mitel Telephony Application Interface (MiTAI) is a powerful telephony API designed for applications requiring sophisticated call- and PBX-control functionality. MiTAI offers a full suite of capabilities from simple third-party call control to contact center monitoring and control.

How it Works

MiTAI follows the client-server model. The server component resides in the call control engine, in this case, the Mitel 3300 ICP or the SX-200 ICP. The client component is co-resident with the application. A MiTAI application accesses the controller/PBX via a LAN connection.

In Figure 2 on page 17, a single MiTAI Server supports a number of applications, most likely resident on a number of client PCs on the network. This would be the case for desktop applications such as screen pops, which are intended to monitor just one phone on one ICP.

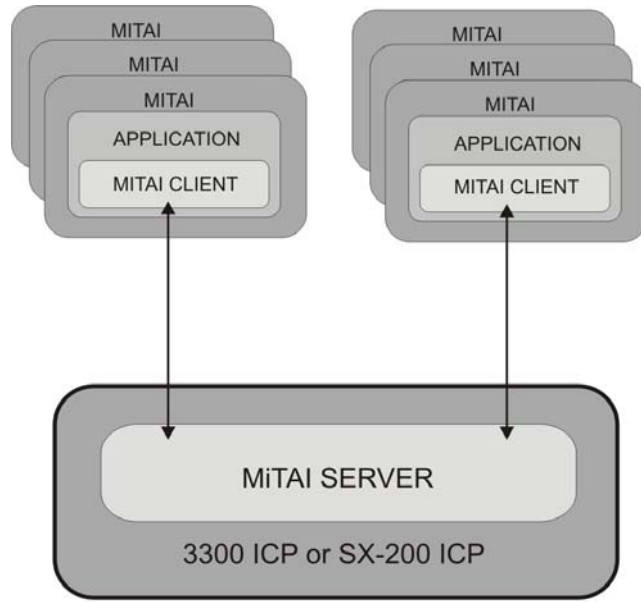

GG1420

Figure 2. MiTAI Configuration - Single MiTAI Server

Figure 3 below illustrates a single MiTAI application communicating with several MiTAI Servers.

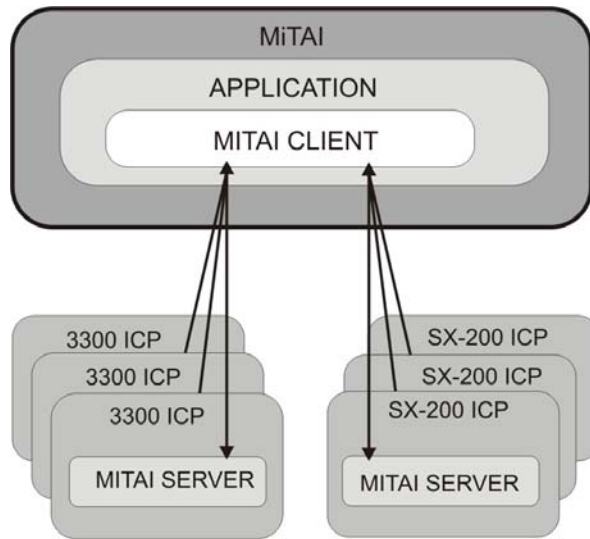

GG1416

Figure 3. MiTAI Configuration - Multiple MiTAI Servers

MiTAI and 3300 ICP Resiliency

A single resilient monitor can be set on a device whereby the application can monitor that device regardless of whether the device is homed to a primary controller or has failed over to its backup controller. It is not necessary for applications to set multiple monitors.

MiTAI and MiAUDIO

MiTAI can integrate with MiAUDIO, enabling the development of applications that require more sophisticated capabilities beyond the standard servicing of calls. Examples of such applications include voice mail or automated call routing systems requiring Dual Tone Modular Frequency (DTMF) detection.

For complete information about MiTAI, see the *MiTAI Developer Guide* available at the MSA-on-MOL web portal. See the Documentation Index on page 31.

MiAUDIO

MiAUDIO enables developers to include the processing of telephone audio streams that are managed from the Mitel 3300 ICP in their applications. Examples of MiAUDIO applications include a voice mail system, or an automated recorded message delivery system.

MiAUDIO is used to control the calls of a physical phone or a workstation softphone. MiAUDIO can receive and interpret DTMF signals while also handling multiple phones, trunk devices, and routing queues. Applications written for MiAUDIO allow for third-party call control (outside of the 'conversation'). MiAUDIO targets server applications controlling multiple devices and handling such things as corporate voice mail, where speech recognition and DTMF detection are required.

How it Works

From an application perspective, MiAUDIO is accessed via the MiTAI interface as shown in Figure 4 on page 18 below.

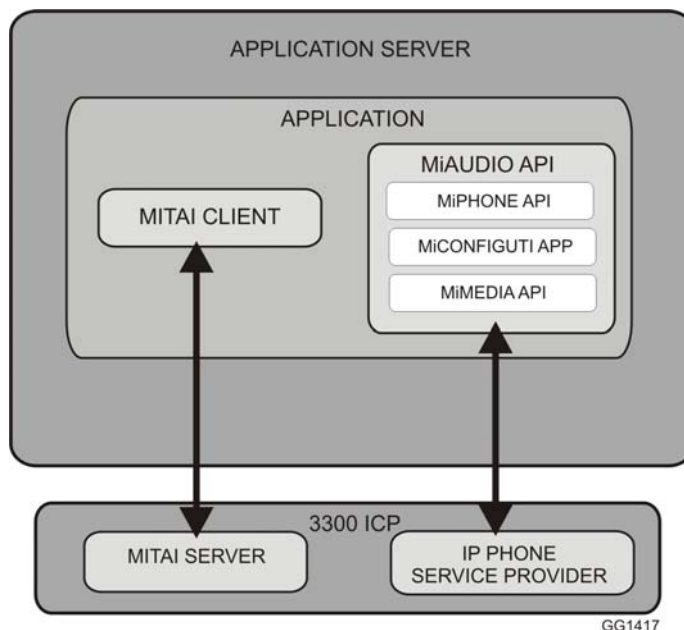

Figure 4. MiTAI Call Control for MiAUDIO

Emulating the Mitel 5020 or 5224 IP Phone controlled by a 3300 ICP, MiAUDIO provides voice port capabilities to server-based applications. MiAUDIO offers the following:

- Up to 60 ports (softphones) for voice applications

- Voice stream record and playback
- Phone and line device interface for monitoring and controlling the softphone
- DTMF generation
- DTMF detection events for IP- and TDM-sourced calls
- Call control via MiTAI

Supported Environments

MiAUDIO is available for 3300 ICP and the SX-200 ICP systems.

For complete information about MiAUDIO, see the *MiAUDIO Developer Guide* available on MOL. See the Documentation Index on page 31.

Secure Recording Connector

Mitel Secure Recording Connector (SRC) is a call recording solution that allows third-party recording equipment to record Mitel encrypted voice streams, see Figure 5. SRC is placed on the LAN and accepts requests from properly authorized Call Recording Equipment (CRE) to establish taps in the voice stream.

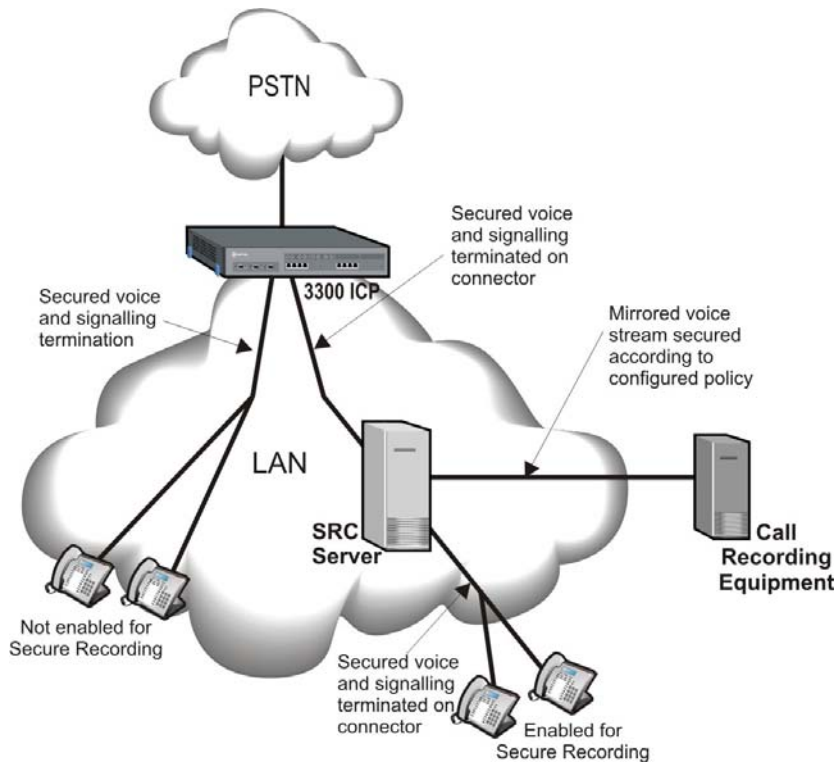

Figure 5: SRC Topology

How it Works

SRC is a Mitel Standard Linux-based (MSL) software blade in the Mitel Border Gateway family. Phones that are enabled for call recording register with the ICP via the SRC. SRC then taps (mirrors) the voice streams of any enabled phone, or group of phones, to third-party

call recording equipment. Developers can use the SRC-CRE interface to add, remove, and query recording taps.

SRC-enabled applications require the purchase of end user SRC licensing as well as (in most system architectures) MITAI license royalty obligations on the part of the MSA Commercial Developer member.

For complete information about SRC, see the *SRC Developer Guide* and the *MiSSL Tunnel Developer Guide*. See the Documentation Index on page 31.

System OAI

The System OAI (Open Architecture Interface) is a CTI interface that allows a wide range of applications to interact with the 5000 CP and the Axxess business communications networks.

How it Works

From an application perspective, System OAI is accessed via a data connection. The connection is established over TCP/IP, or optionally for Axxess, over a serial interface. In multi-node networks, an OAI gateway product, called CT Gateway, offers the application a unified view of the network as shown in Figure 6.

The OAI interface is exposed to the application in different formats. The OAI “over the wire” protocol is well documented, enabling application partners to write their own client library. However, Mitel also provides Java and VC.NET 2008 run-time libraries, which could simplify partner development projects.

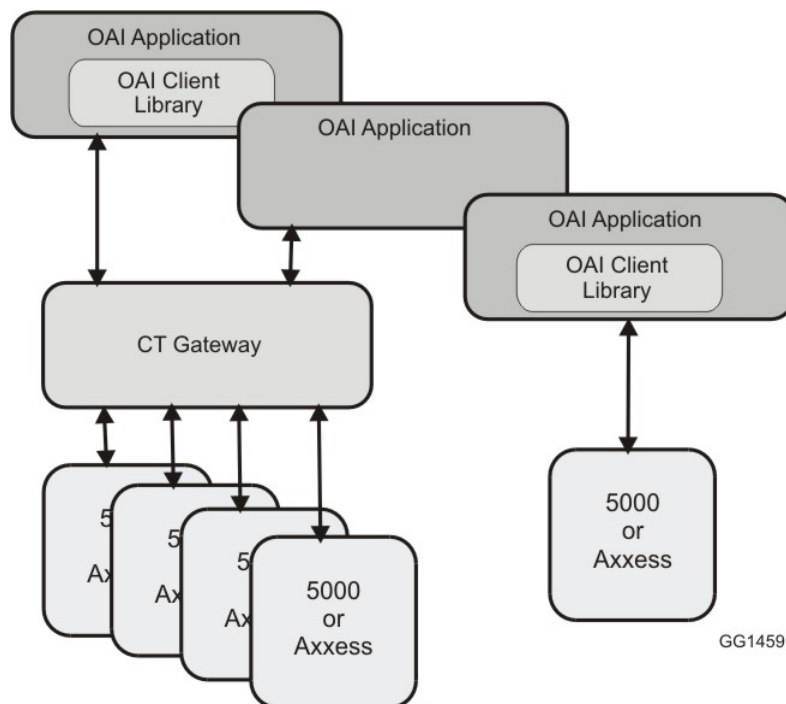

Figure 6: OAI Interface Options and CT Gateway

The OAI interface provides the application with configuration information, device and call event monitoring, display and keypad controls, and third party call control. SMDR records are also accessible via this interface.

Customer Service Manager (CSM) SDK

How it Works

The Mitel Customer Service Manager (CSM) contact center solution includes the ability to provide first party call control of a contact center agent's phone, as well as displaying information about who is calling or being called. It also allows a user to screen pop a customer's record in the company database based on the caller's details, such as the telephone number. CSM includes several "Ready To Go" solutions pre-installed that will screen pop several common databases such as Microsoft® Access®, GoldMine®, etc.

Some customers may use a proprietary database for a specific end-solution, or a database that is not supported by CSM. In such cases, the end-user would need to use a custom action to integrate with their database. The custom action would take information that CSM knows about the call, and then interact with the database using COM, DDE, ODBC, or keystrokes to display the customer's details. This is achieved using a built-in macro language that enables the creation of advanced actions that can perform repeated tasks quickly, based on information entered by the user, or information known by CSM. CSM also has an Active X control that allows a developer to integrate their application with CSM. The CSM Software Developer's Kit (SDK) documents the macro language and the ActiveX® control.

MSA Basic Level Interfaces

Basic level interfaces on Mitel ICPs are accessible over a network connection using TCP/IP Ethernet ports. Data streams are provided on specific ports, with a maximum of three connections for each system application. Member level interfaces are presented in two categories:

- Data Interfaces
- Other Interfaces

Data Interfaces for the 3300 ICP and SX-200 ICP Platforms

SMDR

Station Message Detail Recording (SMDR) is a reporting system on the 3300 or SX-200 ICP platforms that captures information regarding telephone calls and forwards that information to an application. The application can then process call details into reports for such purposes as accounting, security, or capacity planning.

How it Works

When the SMDR package is enabled, telephone call management information is generated by the controller/PBX and formatted into SMDR records or events. SMDR events are then available to applications via TCP/IP.

Figure 7 illustrates this scenario.

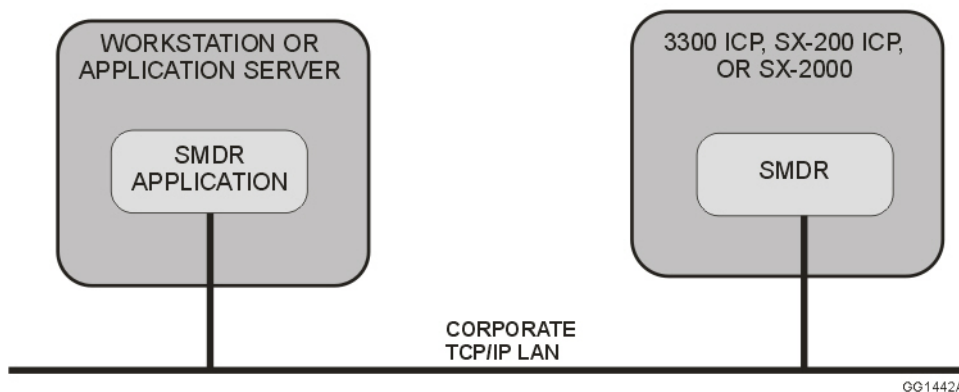

Figure 7. SMDR Application

SMDR provides extensive call management information. Here is a sample of the fields available in an SMDR record:

- Date
- Start Time
- Duration of Call
- Calling Party
- Time to Answer
- Digits Dialed
- Call Completion Status
- Called Party
- Transfer/Conference Call
- Third Party
- Account Code
- Call Identifier
- Call Sequence Identifier

For complete information on SMDR data streams, refer to the *Data Interfaces Specification Programmer Reference* document available at the MSA-on-MOL web portal. See the Documentation Index on page 31.

SNMP

The Mitel 3300 ICP platform supports Simple Network Management Protocol (SNMP). This means that both platforms can be managed from a Network Management System (NMS) such as Mitel's Enterprise Manager. Other network management systems can be used or constructed provided they conform to the SNMP standard. Currently, Mitel platforms support version 1 and version 2c of SNMP.

How it Works

SNMP is an industry-standard protocol used to manage network-attached devices. TCP/IP is the network transport protocol used between the NMS and the devices to be managed. In a typical scenario, each device to be managed runs an SNMP agent which is configured to interact with one or more management systems (managers) on the network. The NMS can monitor and control the device to the degree that the agent is configured to permit it. This control can range from simple read-only status queries to re-configuring and restarting the managed device. To manage Mitel devices and take full advantage of all the available management capabilities, the NMS must be populated with the proprietary Mitel extensions. Figure 8 on page 23, illustrates a Mitel Enterprise Manager managing a Mitel 3300 ICP, an SX-2000®, and an Ethernet switch.

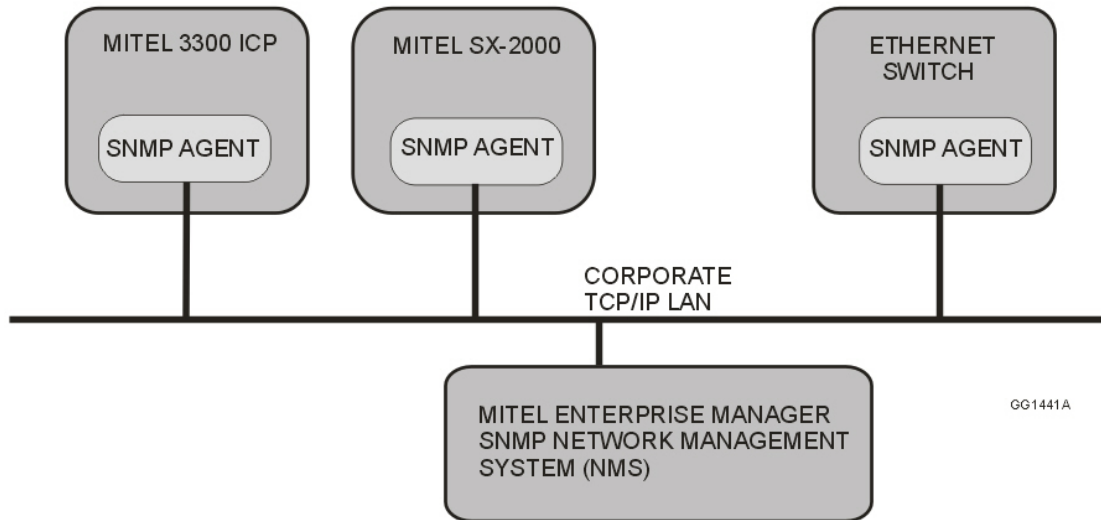

Figure 8. SNMP Application Environment

The SNMP agent in each SNMP-manageable Mitel device has both the industry-standard action-set and the proprietary Mitel extensions specific to the device to be managed.

For complete information on SNMP data streams, refer to the *Data Interfaces Specification Programmer Reference* document available at the MSA-on-MOL web portal. See the Documentation Index on page 31.

Property Management System

A Property Management System (PMS) is used to manage a hotel/motel business. A 3300 ICP, SX-200 ICP, or an SX-2000 system can integrate with a PMS and exchange PMS-related information allowing seamless management of hotel telephone calls from the PMS. A front-desk system can also interface with the PMS to provide reservation control, centralized accounting and billing, and call logging. If desired, the PMS can also be used to automatically manage the Voice Mail system of the controller/PBX.

How it Works

When information about a guest is changed in the front desk system, messages are sent to the PMS which feeds relevant information to the controller/PBX via TCP/IP port 6830. Similarly, when information about any guest is changed on the controller/PBX, messages are sent to the PMS which relays the information to the front desk system. This permits for example, check-in of a guest to automatically update the phone system so that calls in and out are logged and automatically included in the production of the invoice at check-out time.

In addition to controlling calls, PMS integration can automate the management of the controller/PBX voice mail system. This way, a guest can have personalized voice mail added to room phone service.

Figure 9 below shows a PMS application environment.

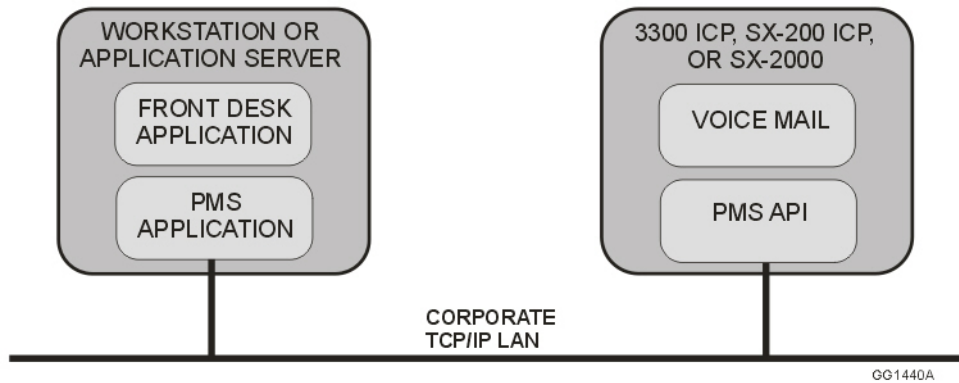

Figure 9. Property Management System Application Environment

A fixed set of commands is used to exchange information between the PMS and the controller/PBX. Developers use this set of commands to build their property management systems to interface to the phone system.

For complete information on PMS data streams, refer to the *Data Interfaces Specification Programmer Reference* document available at the MSA-on-MOL web portal. See the Documentation Index on page 31.

Automatic Call Distribution Real Time Events

Automatic Call Distribution (ACD) is an integrated component of the Call Center Management System that ensures customers are treated equitably and calls are routed efficiently. Incoming calls are routed to the call center agent best suited to handle that inquiry, and if no agents are available, calls are queued and forwarded to an agent when one becomes available. ACD allows call centers to process incoming calls based on user-definable parameters such as origin of call, call hand-off status, personalization of agent workstation, call monitoring, call duration, and many others.

The ACD Real Time Events (ACD RTE) interface provides an application with call information in real time, permitting instantaneous evaluation and realignment of the operation of the call center. For example, if one team of agents becomes completely occupied, members of another team can be deployed automatically to assist using the original team's online tools and information.

How it Works

ACD Real Time Events are used to monitor and record the activity of the entire ACD operation. Events are divided into two groups:

- Agent events
- Group statistics events

Agent events report on individual ACD agent activities and are produced as they happen. Group statistics provide a cumulative report for hunt group congestion and are generated every 15 seconds or more, depending on traffic.

ACD events are obtained via an IP connection at port 15373. Figure 10 below shows this application environment:

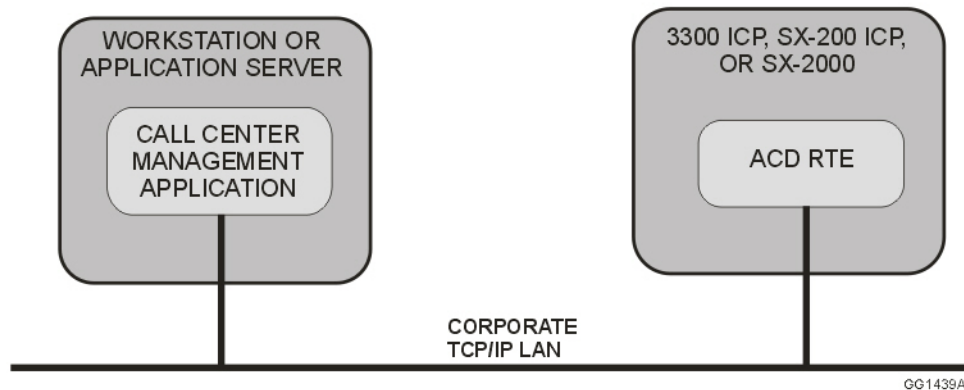

Figure 10. ACD Real Time Events Environment

For complete information on ACD RTE data streams, refer to the *Data Interfaces Specification Programmer Reference* document available at the MSA-on-MOL web portal. See the Documentation Index on page 31.

HTML Toolkit

The HTML Toolkit is a cost-effective way to build, integrate, test, deploy, and promote unique business solutions created with a simple HTML interface. Each business is unique, and now the Mitel 5330 and 5340 IP Phones can be designed to capture everything your business needs.

The Mitel HTML Toolkit allows any Web/HTML developer to create integrated business solutions for the Mitel 53XX IP Phones⁴. The HTML Toolkit consists of an Application Packager, which integrates complete encryption and digital signatures, and an Application Uploader, which creates a secure one-time connection with the Mitel Communications Director (MCD) to upload your newly created Business Solution. All you need to do is create a series of HTML coded pages using standard third-party Web Development tools like Microsoft FrontPage® or Macromedia® DreamWeaver®, and then execute the Packager and Uploader to create a complete business solution.

The standard HTML is augmented by JavaScript and TeiML tags to allow advanced phone functionality, turning the Mitel 53XX IP Phones into unique data portals where businesses can deliver the right information to the right users in an efficient and cost-effective manner.

How it Works

The HTML Toolkit application developer creates a vertical or horizontal application for the Mitel 53XX IP Phone. The application is then packaged by the HTML Toolkit Packager where it is encrypted, compressed, and digitally signed into an SPX file that is uploaded to MCD with the HTML Toolkit Uploader. From the System Administration Tool of MCD, a maintenance command is used to update the system with the new application and to allow access to any licensed 53XX IP Phone.

⁴ The HTML Toolkit supports the 5304, 5312, 5324, 5320, 5330, 5340 and 5360 IP phones. However, the 5304, 5312 and 5324 IP Phones only support the non-Browser Notification Applications.

The centrally-administered applications are easy to deploy to any licensed 53XX IP Phone. The different application types that can be created are as follows:

- **GUI Replacement Applications:** Applications that replace the Mitel Telephony GUI.
- **Full Page Applications:** Applications programmed to a Programmable Key that launch on top of the Telephony GUI.
- **Partial Screen Programmable Key Applications:** Applications that run in the Programmable Key area of the 53XX IP Phone.
- **Screen Saver Applications:** Customize the 53XX IP Phones screen saver.
- **New Page Applications:** The 53XX IP Phones have the ability to add three additional new pages of HTML applications. These Applications run in the Telephony GUI and reside in the Programmable Key Area.
- **Two Easy Branding Applications:** Easily place a customized brand on any 53XX IP Phone with the Phone Branded Application or the Branded Screen Saver Applications. Both applications require only an Image File with the brand and a Manifest File making it very easy to customize your phones with your own branding.
- **Notification Applications:** Send corporate-wide or individual phone notifications with two levels of priority, High and Normal. High Priority notifications appear no matter what state the phone is in (Phone Call) while Normal Priority notifications display only during normal phone states.

For complete information about the HTML Toolkit, refer to the *HTML Toolkit Developer Guide* available at the MSA-on-MOL web portal. See the Documentation Index on page 31.

SIP

Session Initiation Protocol (SIP) is a peer-to-peer, standards-based protocol that facilitates openness, connectivity, simplicity, choice and personalization. SIP is being adopted by major telecommunication service providers around the world. It has also been specified as the call control for the 3GPP next generation cellular network.

Mitel recognizes the promise and potential of SIP, the emerging protocol of choice for setting up telephony, multimedia, conferencing, and other kinds of advanced communication sessions via the internet. Our portfolio of IP-based phones and peripherals, integrated communication platforms and IP-based applications is already among the most advanced and comprehensive on the market. Mitel is proud to be an active member of the SIP Forum and has been involved in IETF's SIP working groups for several years, advancing open global standards for IP communications such as SIP.

How it Works

SIP is a peer-to-peer signaling protocol that can be used to set up and manage any type of communication session, regardless of the media type (phone call, Instant Messaging, gaming, or even live video). In fact, the power of SIP stems from its simplicity and flexibility. SIP is a standard that is being advanced by the Internet Engineering Task Force (IETF). SIP communication uses the same control, addressing, protocols, security and other mechanisms commonly found on IP networks and on the Web. In addition to voice communication features, SIP enables new services that are very difficult or impossible to provide in traditional telephony-centric systems. These include:

- Presence
- Mobility
- User preferences
- Instant multimedia communications: text, voice/video/data
- Advanced multimedia conferencing
- Multiple media: text, voice, video, shared data
- Multiple devices: phones, PC/laptop, handheld computers, pagers

The MSA program encourages SIP interconnection, and works toward the goal of standards and interoperability. However, the SIP protocol is constantly under revision, not only by Mitel, but by the IETF and other standards bodies. Additionally, SIP is a flexible and extensible specification. This all adds up to product-specific interoperability tests. MSA offers a self-assessment program for initial product interoperability tests, and an optional fee-based Mitel certification program. These test programs offer both a quick time-to-market process for deal-driven projects, and a longer certification process for differentiation in a channel marketing program.

For complete information about Mitel's SIP offering, refer to one or more of these documents:

- SIP Lineside Interoperability Guide
- SIP Trunking Interoperability Guide
- SIP Trunking Certification Test Plan

These documents are regularly updated and are posted at the MSA-on-MOL web portal and the Mitel Knowledge Base. See the Documentation Index on page 31.

Axxess/5000 CP Data Interfaces

SMDR

The Axxess and 5000 CP products share the same Station Message Detail Report (SMDR) format, although this is a different format from the 3300 or SX-200 ICP platforms. The SMDR record is designed to support third-party accounting packages. As the 5000 CP evolves, SMDR functionality will continue to expand, resulting in evolving differences in SMDR between Axxess and the 5000 CP.

How it Works

The SMDR can be routed to an external application via a special-purpose TCP/IP connection on the 5000 CP, a printer port on Axxess, or carried to the application over an OAI interface (either 5000 CP or Axxess).

The PBX supports a pre-output configuration filter, so output records fit a certain category of calls. For example, the system can be configured to record only international calls. There is an extensive list of call types visible to this filter.

Exact formats and configuration options for the SMDR output records are defined in the *5000 CP Administrator's Guide* or the *Axxess Administrator's Guide*. In summary, the following fields are included in each SMDR record:

- Call Type
- Trunk
- Start
- Cost
- Extension
- Dialed Digits
- Elapsed
- Account Code

Other MSA Interfaces

Live Business Gateway

In addition to development and data interfaces, Mitel offers the Live Business Gateway – an interface that enables communication between a 3300 ICP platform and Microsoft Office Communicator.

The Mitel Live Business Gateway enables Microsoft Office Communicator, through the use of Microsoft Live Communication Server, to take advantage of all phone services offered by the 3300 ICP. For example, the Live Business Gateway:

- Allows a user to place and receive calls from Microsoft Office Communicator and the Microsoft Office Suite via a Mitel desk phone.
- Provides information about enterprise users to Microsoft Office Communicator and Microsoft Office Suite.
- Uses the industry standard SIP/CSTA protocol, removing the need to understand the Mitel 3300 ICP call control API.
- Allows desktop applications to use the following call control features:
 - Make Call
 - Clear Call
 - Hold
 - Consultation Call
 - Conference
 - Reconnect
 - Set DND
 - Get DND
 - Answer Call
 - Deflect Call
 - Retrieve Call
 - Transfer
 - Alternate Call
 - Set Forwarding
 - Get Forwarding

Live Business Gateway architecture using a standalone application is illustrated in Figure 11. Live Business Gateway software is also available as an Applications Processor Card deployment.

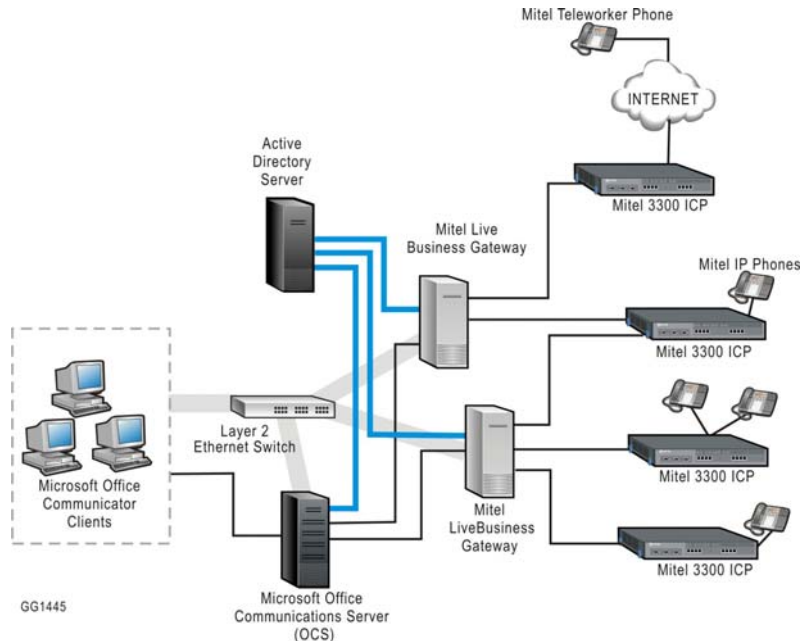

Figure 11. Live Business Gateway Architecture

How it Works

The flow of information is as follows:

1. The Microsoft Office Communicator sends messages to and registers with a Microsoft LCS.
2. The LCS then sends requests to and receives events from the Live Business Gateway on behalf of the Microsoft Office Communicator. The Live Business Gateway communicates with the LCS using SIP/XML/CSTA messages.
3. The Live Business Gateway then sends requests to the Mitel 3300 ICP using Mitel proprietary messages.

For detailed information about Live Business Gateway, refer to the *Live Business Gateway Installation and Maintenance Guide* available on MOL. See the Documentation Index on page 31.

Mitel Contact Center CTI Developer Toolkit

The Mitel Contact Center CTI Developer Tool Kit is a Basic MSA interface for the Mitel Contact Center product that offers server- and client-side programmable, Visual C#, .NET, dynamic link libraries (DLLs) that can be used in any .NET (release 2.0+) application or website. The tool allows developers to use data from third-party IVRs, CRMs, or any ODBC-compliant database for the purpose of phone set control, screen popping, click-to-dial, and other functions.

The DLLs provide:

- Notification of call received events.
- Storage and access to call detail information (for example - ANI, DNIS, Collect Caller Entered Digits, Caller Name, Agent ID).
- Caller information from the Intelligent Queue IVR, third-party IVRs, database lookup, etc.
- Call control.

The CTI Developer toolkit API includes a test application with source code that enables developers to understand how code can be written for their own custom applications. The API also includes a Windows .CHM help file that documents the methods and properties that are programmatically exposed by the API.

The CTI Developer Toolkit integrates with Mitel Call Accounting and/or Mitel Contact Center Enterprise/Business Edition application suites. A base software component purchase of one of these suites is a prerequisite for turning on custom-developed solutions created with this tool.

Additional customer licensing fees are required for deployment.

To download CTI software go to:

[ftp://www.prairiefyre.com/DownloadCenter/prairieFyre_SDK/Current CTI Developer Toolkit.](ftp://www.prairiefyre.com/DownloadCenter/prairieFyre_SDK/Current_CTI_Developer_Toolkit)

 **Note:** Mitel's Call Accounting and/or Mitel's Contact Center Enterprise/Business Edition base software must be purchased prior to using this toolkit. Please contact MSAInfo@mitel.com with proof of purchase (a prairieFyre site key) to obtain username and password.

Unified Communicator Advanced (UCA) Software Development Kit

Mitel offers a programming environment for the Mitel Unified Communicator (UC) Advanced product via the UCA Software Development Kit (SDK). The UCA SDK is intended for programmers integrating UC Advanced into custom solutions. It is based on the Microsoft .NET 2 platform and exposes its classes and members through the Component Object Module (COM) platform. Therefore it can be used in both .NET and COM-compatible languages to develop custom solutions. This SDK is required for a solution to receive telephony events from, and send dial commands to, UCA. The SDK consists of a .DLL, a deployment merge module, and sample applications for C#, VB.Net, and HTML.

TAPI Integration

Microsoft Telephony Application Programming Interface (TAPI) is a widely available desktop API that provides computer-telephony integration. Mitel TAPI integration requires a middle-tier architecture component, provided by partners within the MSA community. End customers and application partners seeking to implement custom TAPI integrations should refer to the "MSA 3PP Integrations-Connectors-Plugins" document on the MSA web portal.

For partners and end customers seeking powerful, direct desktop application integration with Mitel platforms, we offer the following TAPI alternatives:

- MiTAI (3300 ICP platform)
- MiAUDIO (3300 ICP platform)
- CTI Developer Toolkit (3300 ICP platform)
- OAI (5000 CP and Axxess platform)
- Customer Service Manager SDK (3300 ICP, 5000 CP, and Axxess platforms)

CSM SDK is the desktop component of the Customer Service Manager (formerly Contact Center Suite).

Partners are encouraged to investigate our complete integration portfolio before finalizing a TAPI-based project architecture.

IMAP/SMTP

Mitel Messaging products support SMTP and IMAP interfaces, and can behave as a Clients or Servers where:

- An IMAP Server is an email server that provides access to email via IMAP
- An IMAP capable client can connect directly to an IMAP server
- SMTP Server receives messages from SMTP clients
- SMTP Client sends messages to an SMTP server

| Messaging Product | SMTP Client | SMTP Server | IMAP Client | IMAP Server |
|-------------------|-------------|--------------------------|-------------|-------------|
| EM OSE 1.0 | Yes | No | No | Yes |
| EM OSE 1.1/2.0 | Yes | No | Yes | Yes |
| NuPoint | Yes | Yes (VPIM Messages Only) | Yes | No |
| | | | | |

Mitel’s SMTP and IMAP interconnection support is growing. Partners and customers with specific IMAP or SMTP needs that are not listed in the table should speak to an MSA representative.

Documentation Index

Mitel maintains a rich documentation suite at both Mitel OnLine (MOL) and at the MSA web portal on MOL. For information about available documentation and how to access it, refer to:

- [Accessing the MSA web portal on Mitel OnLine](#) on page 32
- [Accessing the Mitel Knowledge Base](#) on page 32
- [Advanced Interfaces Documentation](#) on page 34
- [Basic Interfaces Documentation](#) on page 35
- [Other Interfaces Documentation](#) on page 35
- [Controller/PBX Documentation](#) on page 35

Accessing the MSA Web Portal on Mitel OnLine

 **Note:** For access to most MSA resources, and to all Mitel product documents except telephone user guides, you need an MOL username and password. MSA members can obtain MOL logon credentials upon completion of the membership enrollment process, and credentials remain valid concurrent with active MSA membership.

To access Mitel resources on MOL:

1. Log in to Mitel OnLine (<https://www.ebiz.mitel.com/login.jsp>).
2. Point to **MSA**.

Select from among MSA resources, including:

- Technical Training
- MSA Developer Support
- MSA Downloads (including APIs/SDKs/Sample Code)
- Global Solutions Catalog
- Product Documentation

Accessing the Mitel Knowledge Base

To access the Mitel Knowledge Base:

1. Log in to Mitel OnLine.
2. Point to **MSA Developer Support**, and then click **Knowledge Base**.
3. For example to locate SIP Interoperability Guides, from the **Product** list select **3300 ICP**.
4. In the **Keyword Search** box, type **SIP**.

MSA Interfaces Documentation

Figure 12 illustrates the relationship of the MSA documentation.

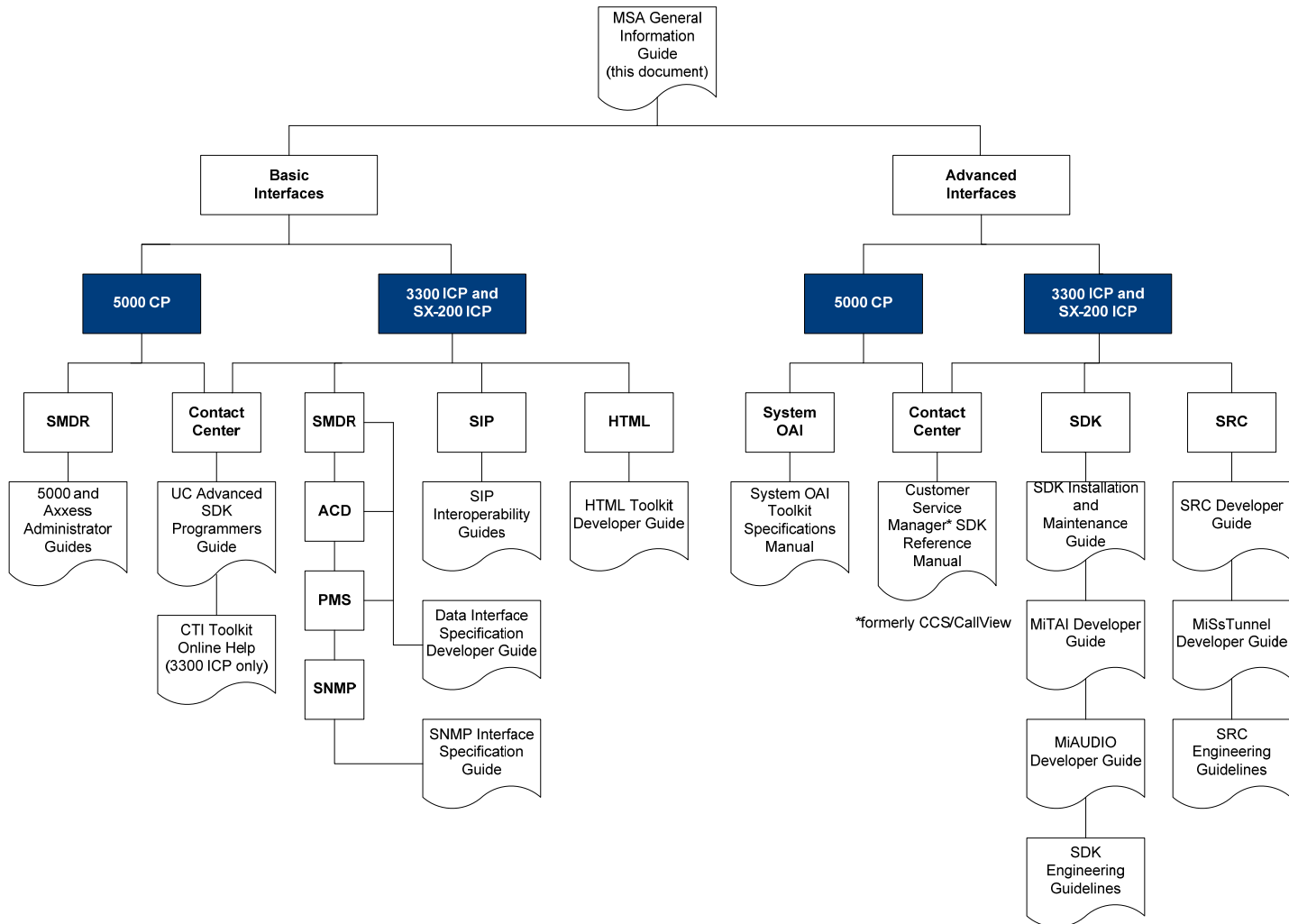

Figure 12. MSA Interfaces Documentation

Advanced Interfaces Documentation

| Topic | Document Name | Detail | Find it at: |
|----------------|---|--|--------------------|
| SDK | Installation & Maintenance Guide | Installation, upgrade, maintenance, and troubleshooting information for all SDK software including MiTAI and MiAUDIO | MSA-on-MOL Portal |
| | MiTAI Developer Guide | Programming, maintenance, and troubleshooting procedures. | |
| | MiAUDIO Developer Guide | Programming, maintenance, and troubleshooting procedures. | |
| | Engineering Guidelines | Assist in planning and installation of SDK software; intended to highlight specific areas of the product that need to be considered before installation. | |
| SRC | SRC Developer Guide | Programming, maintenance, and troubleshooting procedures. | MOL – Product Docs |
| | MiSsITunnel Developer Guide | Programming, maintenance, and troubleshooting procedures for the Mitel application library MiSsITunnel. | |
| | Engineering Guidelines | Assist in planning and installation of SDK software; intended to highlight specific areas of the product that need to be considered before installation. | |
| Contact Center | Customer Service Manager SDK Reference Manual | Documents creation of user-defined actions, along with use of the CSM macro language and Active X control. | MSA-on-MOL Portal |
| System OAI | System OAI Toolkit Specifications Manual | Provide the information and tools you need to interface with and develop applications using the Axxess or 5000 CP System OAI link. | MSA-on-MOL Portal |

Basic Interfaces Documentation

| Topic | Document Name | Detail | Find it at: |
|----------------------|--|--|-------------------|
| SMDR | Data Interface Specifications Guide | Access, programming, maintenance, and troubleshooting procedures. | MSA-on-MOL Portal |
| ACD | | | |
| PMS | | | |
| SNMP | SNMP Interface Specifications Developer Guide | Access, programming, maintenance, and troubleshooting procedures | |
| HTML Toolkit | Developer Guide | Programming, maintenance, and troubleshooting procedures. | |
| SIP | Interoperability Guides - Trunking - Line Side | Functional criteria for SIP User Agent Clients. Support for SIP Trunking and a Certification Test Plan. Note: When available, these documents will be posted to the MSA web site. | |
| SMDR (Axxess & 5000) | Administrator Guide | Configuration and formatting of SMDR. | |

Other Interfaces Documentation

| Topic | Document Name | Detail | Find it at: |
|-----------------------|--|--|--------------------|
| Live Business Gateway | Installation & Maintenance Guide | Installation, upgrade, maintenance, and troubleshooting information. | MOL – Product Docs |
| | Engineering Guidelines | Assist in planning and installation of LBG. | |
| CTI Toolkit | CTI Developer Toolkit Overview | Functional overview, sample applications, common user scenarios, and troubleshooting information. | MSA-on-MOL Portal |
| UCA SDK | Unified Communicator Advanced Software Development Kit Programmers Guide | Describes the programming environment of the Mitel UCA SDK, an optional component of the UCA client. | MSA-on-MOL Portal |

Controller/PBX Documentation

This table lists controller/PBX documentation that can be found in the electronic documentation included with the controller/PBX, and/or at Mitel OnLine:

| Topic | Document Name | Detail |
|---|--------------------------------------|--|
| Mitel Communications Director (formerly 3300 ICP) | General Information Guide | Overview of system and associated peripherals and applications |
| | Technician's Handbook | Installation, upgrade, maintenance, and troubleshooting information |
| | Engineering Guidelines | Assist in planning and installation of 3300 ICP platforms; intended to highlight specific areas of the product that need to be considered before installation. |
| | Hardware Technical Reference | Hardware specifications |
| | Configuration Tool Help | Detailed procedures for configuring 3300 ICP with default database and for migration of other existing systems. |
| | Sys Admin Tool Help | Programming, maintenance, and troubleshooting procedures. |
| | Portable Directory Number (Clusters) | Description of Portable Directory Number (PDN) call processing feature |
| | Resiliency Guide | Comprehensive overview of Mitel resiliency solution |
| SX-200 ICP | General Information Guide | Overview of system and associated peripherals and applications |
| | Technical Documentation | Programming, maintenance, and troubleshooting procedures. |
| | Technician's Handbook | Installation, upgrade, maintenance, and troubleshooting information. Quick reference to maintenance commands and frequently used procedures |
| | Engineering Guidelines | Assist in planning and installation of SX-200 ICP platforms; intended to highlight specific areas of the product that need to be considered before installation. |
| 5000 CP | 5000 CP Installation Guide | Provides information needed to plan, install, program, implement, and maintain any of three configurations of the 5000 advanced communications platform—the CS-5200, the CS-5400, and the CS-5600. |
| | 5000 CP Administrator Guide | Provides system administrators and voice mail administrators with information about the 5000 CP family of products. |
| | 5000 CP Program Planning Sheet | Assist in planning and installation of 5000 platforms; intended to highlight specific areas of the product that need to be considered before installation. |
| | Message Print Diagnostics Manual | Technician reference for diagnostic output from the 5000 CP and Axxess systems. |

Other Documentation

| Topic | Document Name | Detail |
|--|--|---|
| Axxess Converged Communication Platform | Axxess Converged Communications Platform Installation and Maintenance Manual | Provides information needed to plan, install, program, implement, maintain an Axxess Converged Communications Platform. |
| | Axxess Converged Communications Platform Administrator Guide | Provides information and detailed instructions about system hardware and features. Note: Refer to the User Guide provided with each endpoint for simplified instructions about using endpoint and voice mail system features. |
| Customer Service Manager (CSM) (formerly Contact Center Suite) | CSM Installation Manual | Provides information required to plan, install, program, implement, and maintain a Contact Center Suite platform. |
| Enterprise Messaging/OSE | Enterprise Messaging Installation Manual | Provides information required to plan, install, program, implement, maintain, and troubleshoot Enterprise Messaging (EM). |
| | Enterprise Messaging Field Configuration Utility Instructions | Instruction about starting and configuring the Enterprise Messaging Field Configuration Utility (FCU) for use with the EM voice processing unit. |
| | Unified Messaging Open Standards Edition (OSE) Administrator's Guide | Provides information and detailed instructions about system hardware and features |
| Messaging Server | Mitel Messenger General Information Guide | An overview of the Mitel Messaging Server Release 2.0. It describes an all-in-one communication solution that gives users access to applications such as desktop call control, web messaging and administration, instant messaging and wireless connectivity. |
| | Engineering Guidelines | Provides network and server/client PC requirements, feature considerations and specific deployment recommendations. |
| | ActiveX Script Builder Guide | Provides detailed instructions for programming custom ActiveX scripts to provide back-end integration between the Call Manager screen-pop application and any open database connectivity (ODBC)-compliant contact database. |

List of Acronyms

| Acronym | Expanded Phrase |
|---------|---|
| 3PP | Third-Party Partner |
| ACD | Automatic Call Distribution |
| ACD RTE | ACD Real Time Events |
| API | Application Program Interface |
| CCS | Contact Center Suite |
| CEBP | Communications-Enabled-Business-Processes |
| CP | Communications Platform |
| CRM | Customer Relationship Management |
| CSM | Customer Service Manager |
| CTI | Computer Telephony Interface |
| DLL | Dynamic Link Library |
| DTMF | Dual Tone Modular Frequency |
| HTTPS | Secure Hypertext Transmission Protocol |
| ICP | IP Communications Platform |
| IMAP | Internet Message Access Protocol |
| IVR | Interactive Voice Response |
| MCD | Mitel Communications Director |
| MiCD | Multi-Instance Communications Director |
| MOL | Mitel OnLine |
| MSA | Mitel Solutions Alliance |
| MiTAI | Mitel Telephony Application Interface |
| OAI | Open Architecture Interface |
| ODBC | Open Database Connectivity |
| OSE | Open Standards Edition |
| PBX | Private Branch Exchange |
| PMS | Property Management System |
| PSTN | Public Switched Telephone Network |
| SDK | Software Development Kit |
| SIP | Session Initiation Protocol |
| SMDR | Station Message Detail Recording |
| SMTP | Simple Message Transport Protocol |
| SNMP | Simple Network Management Protocol |
| TAPI | Telephony Application Programming Interface |
| TDM | Time Division Multiplexed |

www.mitel.com



| Global Headquarters | U.S. | EMEA | CALA | Asia Pacific |
|--|--|--|--|--|
| Tel: +1(613) 592-2122 Fax: +1(613) 592-4784 | Tel: +1(480) 961-9000 Fax: +1(480) 961-1370 | Tel: +44(0)1291-430000 Fax: +44(0)1291-430400 | Tel: +1(613) 592-2122 Fax: +1(613) 592-7825 | Tel: +61(0) 2 9023 9500 Fax: +61(0) 2 9023 9501 |

For more information on our worldwide office locations, visit our website at www.mitel.com/offices

THIS DOCUMENT IS PROVIDED TO YOU FOR INFORMATIONAL PURPOSES ONLY. The information furnished in this document, believed by Mitel to be accurate as of the date of its publication, is subject to change without notice. Mitel assumes no responsibility for any errors or omissions in this document and shall have no obligation to you as a result of having made this document available to you or based upon the information it contains.

M MITEL (design) is a registered trademark of Mitel Networks Corporation. All other products and services are the registered trademarks of their respective holders.

© Copyright 2011, Mitel Networks Corporation. All Rights Reserved.