



A MITEL
PRODUCT
GUIDE

Unify OpenScape Xpert V8R2

Feature Description

Feature Description

01/2026

Notices

The information contained in this document is believed to be accurate in all respects but is not warranted by Mitel Europe Limited. The information is subject to change without notice and should not be construed in any way as a commitment by Mitel or any of its affiliates or subsidiaries. Mitel and its affiliates and subsidiaries assume no responsibility for any errors or omissions in this document. Revisions of this document or new editions of it may be issued to incorporate such changes. No part of this document can be reproduced or transmitted in any form or by any means - electronic or mechanical - for any purpose without written permission from Mitel Networks Corporation.

Trademarks

The trademarks, service marks, logos, and graphics (collectively "Trademarks") appearing on Mitel's Internet sites or in its publications are registered and unregistered trademarks of Mitel Networks Corporation (MNC) or its subsidiaries (collectively "Mitel), Unify Software and Solutions GmbH & Co. KG or its affiliates (collectively "Unify") or others. Use of the Trademarks is prohibited without the express consent from Mitel and/or Unify. Please contact our legal department at iplegal@mitel.com for additional information. For a list of the worldwide Mitel and Unify registered trademarks, please refer to the website: <http://www.mitel.com/trademarks>.

© Copyright 2026, Mitel Networks Corporation

All rights reserved

Contents

1 History of changes.....	7
2 Overview of OpenScape Xpert Features.....	9
2.1 New Features in OpenScape Xpert V7.....	9
2.1.1 New Features in OpenScape Xpert V7.0.1.....	10
2.1.2 New Features in OpenScape Xpert V7.0.7.....	10
2.1.3 New Features in OpenScape Xpert V7.1.0.....	10
2.1.4 New Features in OpenScape Xpert V7.2.0.....	10
2.1.5 New Features in OpenScape Xpert V7.2.1.....	11
2.1.6 New Features in OpenScape Xpert V7.2.2.....	11
2.1.7 New Features in OpenScape Xpert V7.2.3.....	11
2.1.8 New Features in OpenScape Xpert V7.3.1.....	11
2.1.9 New Features in OpenScape Xpert V7.3.4.....	11
2.1.10 New Features in OpenScape Xpert V7.4.0.....	11
2.1.11 New Features in OpenScape Xpert V7.4.1.....	12
2.1.12 New Features in OpenScape Xpert V7.4.2.....	12
2.1.13 New Features in OpenScape Xpert V7.5.0.....	12
2.2 New Features in OpenScape Xpert V8.....	12
2.2.1 New Features in OpenScape Xpert V8.0.0.....	12
2.2.2 New Features in OpenScape Xpert V8.0.20.....	13
2.2.3 New Features in OpenScape Xpert V8.1.0.....	13
2.2.4 New Features in OpenScape Xpert V8.1.1.....	13
2.2.5 New Features in OpenScape Xpert V8.2.0.....	13
3 Features of OpenScape Xpert Terminals.....	14
3.1 Presence List (Attendant List).....	14
3.2 Call Queue.....	14
3.3 Computer Telephony Interface CTI 1st Party.....	18
3.4 Authentication.....	18
3.5 Contact Interface Local/Central.....	19
3.6 Direct Keys.....	22
3.7 Dynamic and Static IP Addresses.....	26
3.8 Open Listening.....	26
3.9 Encryption at the OpenScape Xpert Terminal.....	26
3.10 Freely Programmable Keys.....	26
3.11 Saving or Refreshing User Profile.....	27
3.12 Number of Keys per Profile and Page.....	28
3.13 Dial Pad.....	28
3.14 Disconnect.....	29
3.15 Graphical User Interface.....	30
3.16 Call Control Field (Speech Units).....	30
3.17 Muting the Handset Microphone.....	33
3.18 Kill Line Function Key.....	33
3.19 Using the Mouse and Keyboard (Short Cut).....	34
3.20 Progress Indicator at the Terminal (Progress Control).....	34
3.21 Hold and Private Hold.....	35
3.22 About Window.....	37
3.23 Redial Number.....	37
3.24 Login.....	37
3.25 Logout.....	38
3.26 Macro Key.....	39

Contents

3.27 Menu Buttons on the Main Tool Bar.....	40
3.28 Simultaneous Lines per OpenScape Xpert Terminal.....	41
3.29 "Go to Page" Function Key.....	42
3.30 Pages.....	42
3.31 Receive Calls Only.....	43
3.32 Ring Tone (Ringer).....	43
3.33 Ring Transfer, Ring Transfer Sequence, Sequence Exclusive Group und Keep Active Group.....	44
3.34 Languages.....	46
3.35 TAPI Interface for Third-Party Applications.....	47
3.36 Web Interface.....	47
3.37 Telephone Directory.....	49
3.38 Speech-Sensitive Signaling on the SPM.....	51
3.39 Speech Monitoring (SPM).....	51
3.40 Central Voice Recording (IP).....	53
3.41 Multi-Streaming to Voice Recorders.....	54
3.42 OpenScape Xpert Terminal Soft Client for Back and Middle Office.....	55
3.43 Remote Access through a Firewall.....	56
3.44 Online Help.....	56
3.45 Screen Display and User Mode.....	56
3.46 Keys on the OpenStage Xpert 6010p/Mitel Xpert 6020p Units.....	57
3.47 2-in-1 Function.....	57
3.48 US Call Tones.....	57
3.49 Date and Time Display.....	58
3.50 Automatic Echo Cancellation.....	58
3.51 Speaker Module (Add-on Device).....	58
3.52 How to Call during an Announcement (Hoot-n-Holler Function).....	61
3.53 Feedback tones during dialing.....	61
3.54 Re-ring Signal.....	61
3.55 Suffix Dialing for DKM Keys.....	62
3.56 Control Characters for Dialing Delay.....	62
3.57 Confirmation Prompt before Exiting the OpenScape Xpert Client Software.....	62
3.58 Ring Tone Disabled Display on Line Keys.....	63
3.59 Displaying the Number of the Assigned Speech Unit.....	63
3.60 Volume Normalization for SPM Channels.....	63
3.61 Location identification for emergency calls (E911 support).....	64
3.62 "SPM-to-handset" function key.....	64
3.63 Visual announcement indicator on SPM channels.....	65
3.64 OpenScape Voice UC Basic Integration.....	65
3.65 Extension to 24 Speech Monitoring Channels.....	65
3.66 Screensaver Settings on OpenStage Xpert 6010p/Mitel Xpert 6020p.....	66
3.67 Improved Menu Dialog System.....	66
3.68 OpenScape Xpert Client Usability Improvements and Maintenance Mode.....	67
3.69 Call Forward ON and OFF Function Keys.....	69
3.70 Cleaning.....	70
3.71 Configurable statusbar text.....	70
3.72 Shared Audio with Soft Client.....	70
3.73 Configurable font size.....	70
4 Features of Lines.....	71
4.1 Line Seizure.....	71
4.2 Privacy per Line.....	73
4.3 Voice Recording Switchable at the OpenScape Xpert Terminal (per Line).....	74
4.4 Voice Recording per Line.....	74
4.5 "Different Dial Prefix" FK.....	75
4.6 "Hold Concentrator" Function Key.....	75
4.7 Automatic Recall for Calls on Hold.....	76

4.8 Incoming Call Concentrator.....	76
4.9 Quick Conference.....	76
4.10 Own Line in the Call Memory.....	77
4.11 Multi-Line Appearance (MLA) with OpenScope Voice.....	78
4.12 Preferred Identity Number.....	78
4.13 Two Lines on the Same Button.....	79
4.14 Mass Call Forward List.....	80
4.15 Transit.....	80
5 Features of a User Group.....	81
5.1 Free Seating.....	81
5.2 Intercom.....	81
6 Features of a Line Group.....	83
6.1 Disconnecting All Lines.....	83
6.2 Line Sharing.....	83
7 Features of the System Manager.....	84
7.1 Administrator Roles and Permissions.....	84
7.2 Presence List.....	84
7.3 Automatic Login after Release.....	84
7.4 Backup/Restore Function and Backup Wizard.....	85
7.5 Export/Import Functions.....	85
7.6 User Profile.....	87
7.7 Line Group Overflow.....	88
7.8 Loading the System Configuration (MLC and Trading Terminals).....	88
7.9 Master Password for Service.....	89
7.10 Migration of the Database.....	89
7.11 Multiple Changes to the User Profile.....	90
7.12 Online Help.....	90
7.13 Login / Logout.....	90
7.14 Remote Administration and Diagnosis.....	90
7.15 Search, Replace or Delete.....	91
7.16 Installing and Uninstalling.....	91
7.17 System Manager Cluster.....	91
7.18 Perpetual Licenses.....	93
7.19 Subscription Based Licenses.....	94
7.20 Central License Server.....	94
8 Multi-Line Controller (MLC).....	95
8.1 Operating System and Services.....	95
8.2 Session Initiation Protocol (SIP).....	95
8.3 Scalability.....	96
8.4 IPv4 Support.....	96
8.5 Digitizing Analog Audio Signals.....	96
8.6 Early Media.....	97
8.7 Domain Name System Service (DNS SRV).....	98
8.8 SIP over TCP.....	99
8.9 Quality of Service (QoS).....	100
8.10 Warm/Hot Standby MLC.....	101
8.11 MLC Overload Protection.....	103
8.12 MLC continuous SIP Message Tracing.....	104
8.13 Automatic redial.....	104
8.14 Support of Unify Office Cloud lines.....	104
8.15 Direct connection to Cisco PBX.....	104
8.16 UDP hole punching.....	105

9 Application Programming Interface (CTI API)..... 106

10 Thrift-Based API..... 108

11 Service..... 110

11.1 Secure Remote Access (Service) SiRA..... 110

11.2 Remote Patch and Update Process HiSPA..... 110

11.3 Fault Management with CAP FM..... 110

11.4 Central Image Distribution via Diagnosis Tool..... 110

11.5 Virtual Network Computing (VNC)..... 111

12 Limitations..... 112

12.1 Applications at OpenScape Xpert Terminals..... 112

Index..... 113

1 History of changes

Changes in V8R2

Changes in V8R1.1

Impacted chapters	Change description
Overview of OpenScape Xpert Features on page 9 New Features in OpenScape Xpert V8.2.0 on page 13 Features of OpenScape Xpert Terminals on page 14 Dynamic and Static IP Addresses on page 26 Screen Display and User Mode on page 56 Keys on the OpenStage Xpert 6010p/Mitel Xpert 6020p Units on page 57 Automatic Echo Cancellation on page 58 Screensaver Settings on OpenStage Xpert 6010p/Mitel Xpert 6020p on page 66 Multi-Line Controller (MLC) on page 95 Operating System and Services on page 95	Updated chapters to include the software support of the new Mitel Xpert 6020p

Impacted chapters	Change description
Overview of OpenScape Xpert Features on page 9 OpenScape Xpert Multi-Line Controller MLC OpenScape Xpert V8 Terminal SIP PBX Operating System and Services on page 95 Multi-Line Controller (MLC) on page 95 Features of the System Manager on page 84	Updated OpenScape Xpert version, supported PBXs and Windows Server version.
New Features in OpenScape Xpert V8.1.1 on page 13	New chapter

Changes in V8R0

Impacted chapters	Change description
New Features in OpenScape Xpert V8 on page 12	Add new chapter
New Features in OpenScape Xpert V8.0.0 on page 12	Add new sub-chapter

History of changes

Impacted chapters	Change description
Call Queue on page 14	Changed information about the timer displayed in the upper right corner instead of left corner as stated initially.
Perpetual Licenses on page 93	Modified chapter name from "Floating Licenses" to "Perpetual Licenses".
Configurable font size on page 70 Subscription Based Licenses on page 94 Support of Unify Office Cloud lines on page 104 Direct connection to Cisco PBX on page 104 UDP hole punching on page 105	Add new sub-chapters
Remote Administration and Diagnosis on page 90	Updated information about the supported browsers.

2 Overview of OpenScape Xpert Features

NOTICE:

Depending on the version and licenses, the features described in this document may not be available or may be restricted.

OpenScape Xpert consists of the following system components:..

- OpenScape Xpert Multi-Line Controller MLC (Softswitch)
- OpenStage Xpert 6010p Terminal with Touch Screen or
- OpenScape Xpert Client Terminal (PC with Softclient)
- Peripheral devices, e.g.,:
 - Handset(s)
 - Loudspeaker
- OpenScape Xpert System Manager database
- SIP PBX (Proxy, Registrar) and Gateways
- IP voice recording (optional)
- IP network

NOTICE:

In this document, the term usually "OpenScape Xpert terminals" refers to both terminal types: OpenScape Xpert Client and OpenStage Xpert 6010p.

2.1 New Features in OpenScape Xpert V7

This section contains the features introduced for OpenScape Xpert V7.

- OS hardening according to the Security Technical Implementation Guide (STIG)
- SDES based SIP Payload encryption
- Mutual TLS (M-TLS) based SIP Signaling Encryption
- IPv6 SIP - ANAT support
- Security Technical Implementation Guide (STIG) compliant OSX Client application changes
- OS hardening according to the Security Technical Implementation Guide (STIG)
- Security Technical Implementation Guide (STIG) compliant OSX Database hardening
- Smart Card Login on OSXMP
- Secure HTEMS
- Securing all internal communication between MLC, TT and SM with MTLS
- Audit Trail for SM Changes
- Creating audit logs from all events on the SM in the Windows event log ot to a central Syslog server
- HTEMS over IPv6
- Support of IPv6 between MLC, TT and SM

Overview of OpenScape Xpert Features

- Secure RTP between TT and MLC
Securing the internal media stream between MLC and TT
- Smart Card Login on OSX Client
- SELinux on OSX Client Linux image
Hardening to comply with the requirements described in the Us DoD STIGs
- Push 2 talk in-band signaling support for Radio Gateway
- OS and Database hardening according to the Security Technical Implementation Guide (STIG)
Hardening all used OS and Database for comply with the requirements described in the Us DoD STIGs
- Debian V9 based image for Turrets
OSX Client is running now on newest Debian V9 distribution
- SIPREC based voice recording support with encryption and IPv6

2.1.1 New Features in OpenScape Xpert V7.0.1

This section contains the features introduced for OpenScape Xpert V7.0.1.

- Mass certificate deployment for TT
- MLC via Diagnosis Tool

2.1.2 New Features in OpenScape Xpert V7.0.7

This section contains the features introduced for OpenScape Xpert V7.0.7.

- Visual indication for Call Forward edit mode

2.1.3 New Features in OpenScape Xpert V7.1.0

This section contains the features introduced for OpenScape Xpert V7.1.0.

- Automatic login of the last used profile
- Automatic SW Download
- CSTA Presence Indication on DKA for OpenScape 4000
- IBM Java instead of Oracle Java
- LLDP-MED with auto VLAN configuration
- Thrift API SDK
- Thrift API: 3rd party conference

2.1.4 New Features in OpenScape Xpert V7.2.0

This section contains the features introduced for OpenScape Xpert V7.2.0.

- CSTA Presence Indication on DKA for OpenScape Voice
- Internal Sound Card Support on Incotel/Shuttle Linux and Windows 10 Soft Client
- Location Based SIPREC Voice Recording
- Mass Call Forwarding

- MS Windows Server 2019
- Responsive Toolbar & Status Bar

2.1.5 New Features in OpenScape Xpert V7.2.1

This section contains the features introduced for OpenScape Xpert V7.2.1.

- ELO Touch 2002 monitor on Linux clients
- Jabra 930 Pro Mono
- Unify Code Signing Certificate for Windows installer and tools

2.1.6 New Features in OpenScape Xpert V7.2.2

This section contains the features introduced for OpenScape Xpert V7.2.2.

- ELO Touch 2002 monitor on soft clients (touch control only)

2.1.7 New Features in OpenScape Xpert V7.2.3

This section contains the features introduced for OpenScape Xpert V7.2.3.

- Plantronics / Poly 92842-01 PTT adapter with Encore Pro HW510 and H251N-CD

2.1.8 New Features in OpenScape Xpert V7.3.1

This section contains the features introduced for OpenScape Xpert V7.3.1.

- N5 Based USB Analog Adapter
- New Line State Style
- New OSXMP roles
- SmartPTT Radio Gateway Integration
- The Private Contact List can be sorted by DKA
- Thrift API enhancements
- Transit

2.1.9 New Features in OpenScape Xpert V7.3.4

This section contains the features introduced for OpenScape Xpert V7.3.4.

- The default password of the OSXMP Administrator can be changed.

2.1.10 New Features in OpenScape Xpert V7.4.0

This section contains the features introduced for OpenScape Xpert V7.4.0.

- Debian 11 on the MLC
- Debian 11 on the turret
- Line(s) can be deleted from the result list of the Search Line dialog

Overview of OpenScape Xpert Features

New Features in OpenScape Xpert V8

- Macro Key double press is blocked
- Search by position (page & row & column) on profile(s)
- Separated QoS settings for Windows and Linux devices
- The “Button Press Overload” functionality has been removed
- The Call Control field do not pop up automatically anymore on a 60-button page when activating Consultation or Call Forwarding

2.1.11 New Features in OpenScape Xpert V7.4.1

This section contains the features introduced for OpenScape Xpert V7.4.1.

- Blind Transfer
- Cleaning
- Search by position on “Different” keys in profile bulk edit
- XTB integration

2.1.12 New Features in OpenScape Xpert V7.4.2

This section contains the features introduced for OpenScape Xpert V7.4.2.

- Support of Shuttle DS20
- Turret image 4.0.4 with UEFI boot

2.1.13 New Features in OpenScape Xpert V7.5.0

This section contains the features introduced for OpenScape Xpert V7.5.0.

- Automatic redial
- New audio devices - Poly headsets
- Shared audio device with Softphones - WASAPI support
- DKA busy indication several PBX - multi CSTA
- Timer for CallQueue
- Configurable status bar text
- Support of Unify Office Cloud lines
- Wildfly Security Module: Elytron
- IBM Java 11
- Enhanced license grace period of 30 days

2.2 New Features in OpenScape Xpert V8

2.2.1 New Features in OpenScape Xpert V8.0.0

This section contains the features introduced for OpenScape Xpert V8.0.0.

- Direct connection to Cisco
- UDP hole punching
- Volume control widget for SPM channels and units
- Configurable font size

2.2.2 New Features in OpenScape Xpert V8.0.20

This section contains the features introduced for OpenScape Xpert V8.0.20.

- Ubuntu for FIPS compliance
- Support SIP - Update with OSCAR
- TLS 1.3 / OpenSSL 3.0 FIPS
- Local DNS caching on the MLCs
- Multiple Thrift API connections - PSR only
- MiVoice 5000 support
- Shuttle DS50U support
- ADSTEC Touch Monitor support

2.2.3 New Features in OpenScape Xpert V8.1.0

This section contains the features introduced for OpenScape Xpert V8.1.0.

- Locally (Database) managed administrator users on OSXMP
- Disable Profile
- Absolute timeout for OSXMP session
- Ubuntu 20.04 based Client image only for DoD hardened Shuttle DS10U3 and Tegar TB-5545-MVS PCs

2.2.4 New Features in OpenScape Xpert V8.1.1

This section contains the features introduced for OpenScape Xpert V8.1.1:

- OpenSSL upgrade to FIPS compliant 3.1.2
- IBM Java 21
- MS Windows Server 2022 support for SM
- MS Windows 11 support for Soft Client
- Ubuntu 22.04 based Client image
- Ubuntu 22.04 support for MLC
- Mitel MxOne integration
- Mitel rebranding for Client

2.2.5 New Features in OpenScape Xpert V8.2.0

This section contains the features introduced for OpenScape Xpert V8.2.0.

- Ubuntu 24.04 common platform
- Software Support of the new Mitel Xpert 6020p
- Mitel MiVoice Business integration
- Prevent upgrade w/o SWA
- ASC Neo V8 support

3 Features of OpenScape Xpert Terminals

This section describes the features of OpenScape Xpert terminals.

NOTICE:

In this document, the term usually "OpenScape Xpert terminals" refers to all terminal types: OpenScape Xpert Client, OpenStage Xpert 6010p and Mitel Xpert 6020p.

3.1 Presence List (Attendant List)

The "Login List" function key or the "Profiles Logged In" menu dialog can be used to display the presence of OpenScape Xpert users in the system.

The profile names of the logged in terminals, including those in the "Receive Calls Only" state, are displayed. The list does not provide any information on the call processing status of the users logged in at the terminals.

3.2 Call Queue

The call queue shows calls in the "ringing" or "hold" states.

The call queue appears on the page being currently displayed for the user. The display may be:

- persistent (cannot be turned off)
 optional (i.e., can be turned on and off by the user)

Depending on the number of speech units (1-4) used and the GUI version, the call queue group field contains from four to eight call queue buttons.

The call queue buttons show the respective call states. The signaling of the states matches that of the line keys. In the upper right corner of the buttons, a timer displays the time that has elapsed since the line entered either ringing or common hold state. The buttons in the call queue display can be used to accept and toggle calls.

The call queue display can be enlarged to show three columns, including "ringing lines", "lines placed on hold by the user (without remote seizure)" and "lines placed on hold by other users in the system (with remote seizure)".

Functions

- Signaling
- Switching between normal and full-screen mode
- Display in normal mode
- Display in full-screen mode
- Concentrator for answering calls
- Ring tone off/on for OpenScape Xpert terminal

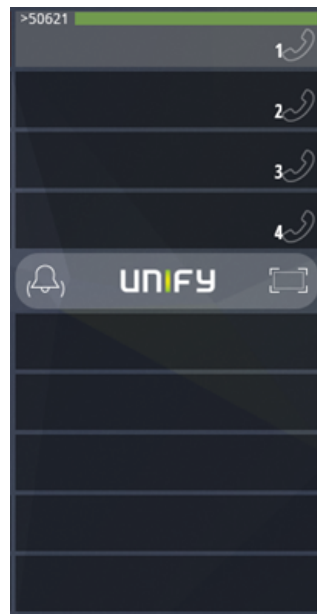

The field above shows the call control field with the display of the 4 handsets.

The fields that follow show the call queue. Incoming calls are displayed from the top to the bottom by time and the priority of the lines. Lines with higher priority precede (i.e., skip) those with lower priorities.

Lines on hold are shown on the lower buttons.

Zoom-In Icon

The user can select the **Zoom-In** icon on the right side of the Unify logo to get to the zoom call control field area. The zoom call control field area provides 3 sub-areas:

- the ringing lines,
- the seized by another lines (including private hold and privacy off) and
- the other lines on hold (without remote seizure).

The user can leave this view by pressing one of the three **Zoom-Out** icons.

Features of OpenScape Xpert Terminals

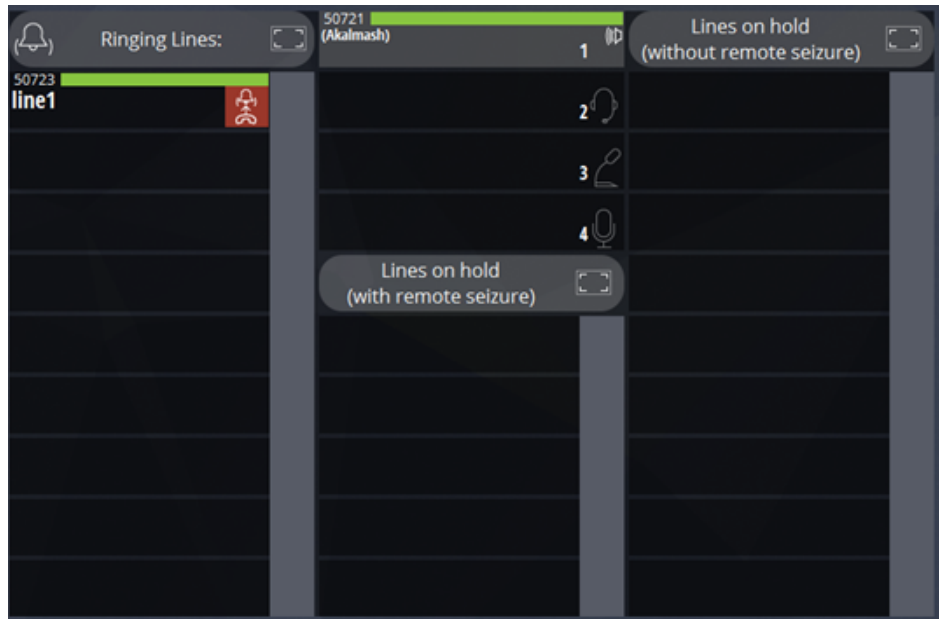

Settings

The System Manager can be used to set whether or not a line is to be displayed in the call queue (Call Queue Entry/Concentrator Active check box) and also whether shared lines on common hold across multiple OpenScape Xpert terminals (Common Hold in Call Queue/Concentrator check box) should be displayed.

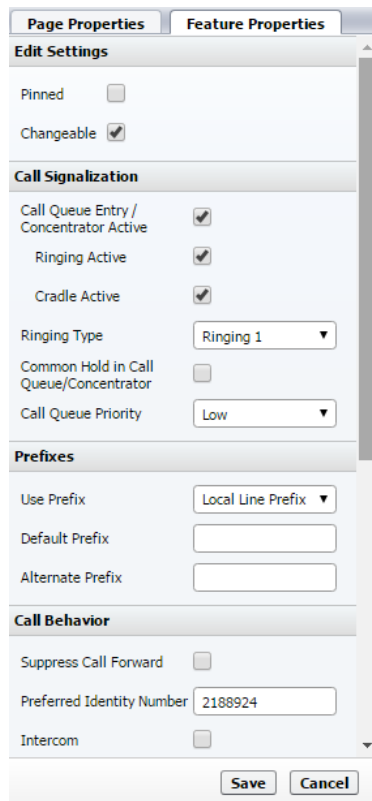

Saving the call control field and call queue to persist on each page

If a call control field / call queue was activated manually (shown) by the user, and the user changes the page and subsequently returns, the previously activated CCP/call queue will be displayed again.

Call Memory (Call Journal)

The call memory (call journal) automatically saves all connections (configurable for incoming/outgoing) made via the OpenScape Xpert terminal or shared lines. It includes a maximum of 100 different entries. The oldest entries are replaced by the newest. An entry is created even if the name or number is not known.

Only the lines defined by the system administrator are taken into account. The settings cannot be changed by the user.

Call memory entries are stored in the central database at intervals of 60 minutes and automatically at logout and are presented again following the next login. If the OpenScape Xpert terminal is set to "Receive Calls Only" (i.e., outbound dialing is blocked), the call memory continues to be updated. No entries are stored in the logged out (logoff) state. OpenScape Xpert users with shared lines may receive identical entries in the call memory.

The call memory entry consists of:

- Name and number of the calling or called party
- Date and time of the connection
- Line and status

The status field displays one of the following entries:

- outgoing local
- outgoing remote
- incoming, answered locally
- incoming, answered remotely
- incoming, unanswered and not yet viewed (shown with a red text color)
- incoming, unanswered and already viewed (shown with a black text color)

The call memory can be protected against unauthorized access by a password. On opening the call memory, an authorization prompt will then be displayed. The password for the call memory can be changed by the system administrator and the terminal user.

Functions

- Open/Exit call memory
- Open call memory with password
- Select display criteria
- Call Memory - select entry
- Call Memory - delete entry
- Set up connection from call memory
- Set up connection from call memory followed by suffix dialing
- Add call memory entry to Contacts
- Filter setting for automatic saving (incoming, outgoing, all)

3.3 Computer Telephony Interface CTI 1st Party

Information between the terminal and other applications such as the PC, host, workstation, etc., is exchanged via the LAN interface of the OpenScape Xpert terminal using the OpenScape Xpert CTI protocol "HTE".

Among other things, the following information of the terminal can be made available via this interface/protocol:

- Line information and status, e.g., seized, disconnected, CLIP (Name), dialing
- Voice recording (on/off, port)
- Status of the terminal (logged in, logged out, disconnected)

The terminal can also be controlled via this interface/protocol:

- Login, logout, receive calls only
- Seize line, dial, disconnect

The possible applications for this interface include:

- Analog voice recording
- Digital voice recording
- Databases (customer file)
- Control from remote applications
- Call detail and call charge recording, presence control
- Statistical reports
- Tracing, diagnostics, logging

More information on the OpenScape Xpert CTI interface can be obtained from the CTI/API specification.

3.4 Authentication

Every user profile can be protected by the system administrator against unauthorized access by means of a password.

The authentication can be done based on the information stored in the database or against an Active Directory Server.

For database authentication the login password can be changed by the system administrator and the user of the profile. Passwords are always shown hidden under asterisks (*****) and consist of at least 5 and up to 15 characters.

To authenticate the user with the Active Directory server the LDAP connection must be set up in the System Manager.

System Properties

System wide settings

General Turret Settings QoS **LDAP**

LDAP Settings

LDAP Enabled

Host Name

Port

Default Domain

SSL Enabled

LDAP Test

User Name

Password

Test

User Name and Password is not stored they are used only for testing the authentication.

3.5 Contact Interface Local/Central

The OpenScape Xpert Contact Interface (CI) offers relay contacts, which can be controlled from OpenScape Xpert workplaces.

The following tables show the CI functions of OpenScape Xpert with respect to input and output.

General CI Functions

CI Function	Local contact interface	Central contact interface
Output	Max. 4	24 or 196
Input	Not possible	Not possible

CI Functions - "Output"

CI Function - Output	Local contact interface (CI)	Central contact interface
In call state	Yes	Yes

Features of OpenScape Xpert Terminals

Specific speech unit in call state	Yes	Yes
Incoming call	Yes	Yes
Incoming call on specific line	Yes	Yes
Speech button status (PTT)	Yes	Yes
"CI Output" (Locking/Non-locking) Function Key	Yes	Yes

Local Contact Interface (Local CI)

OpenScape Xpert provides analog contacts at the OpenScape Xpert terminal (local) by using a contact interface box with USB port from the vendor Ontrak (Type: ADU200). The local contact interface supports up to four relay contacts.

OpenScape Xpert Soft Client & USB



The contact interface box must be procured directly from the vendor Ontrak (see <http://www.ontrak.net>). Please also refer to the technical information of the manufacturer.

Central Contact Interface (Central CI)

OpenScape Xpert provides analog contacts at the central server PC (central) by using a contact interface card with PCI and PCIe (PCI Express) ports (5V) from the vendor Adlink (Type: PCI DIO, with adapter cable and relay board). The central contact interface card and a relay board support up to 196 relay contacts, depending on the type.

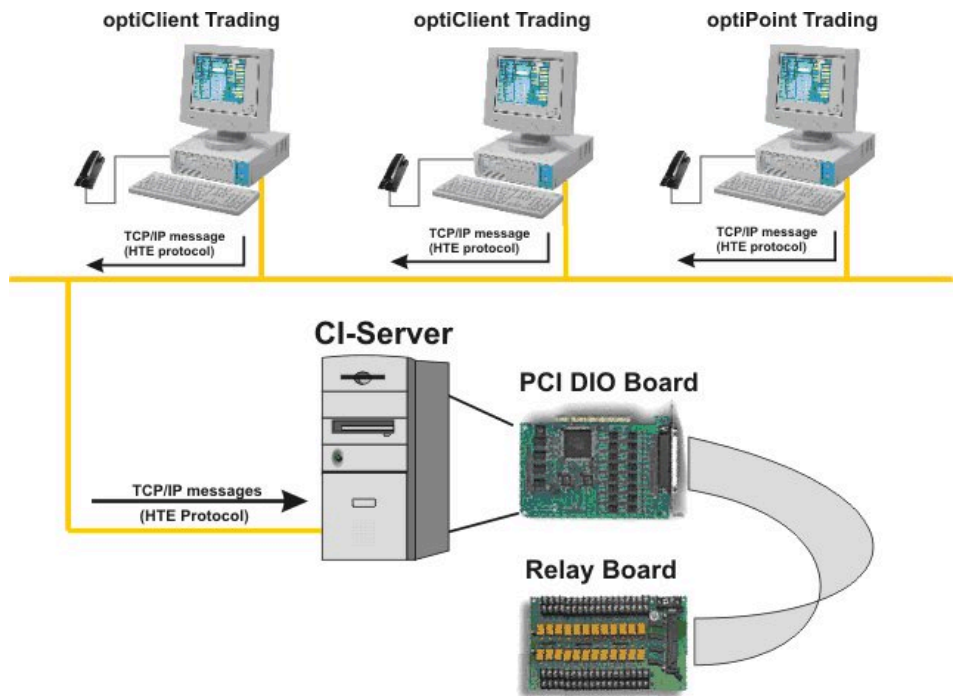

The contact interface card must be procured directly from the vendor Adlink (see <http://www.adlinktech.com>). Please also refer to the technical information of the manufacturer.

"CI Output" (Locking / Non-locking) Function Key

Up to 6 "Contact Output" function keys (FKs) can be programmed per profile at the System Manager. Each "Contact Output" function key receives a fixed description of the function, e.g., "Door opener". In addition, for each "Contact Output" function key, the function "Switch" (toggle, default) or "Pushbutton" can be programmed.

The contact is disabled

The contact is enabled

The existing API protocol (HTE) is adapted for the "Contact Output" function keys. The "Contact Output" function keys can be implemented with both the CI Interface or the central OpenScape Xpert CI Server. A CI key is only assigned to a physical contact. The CI is programmed via the "ConfigData.xml" file, which is a component of the OpenScape Xpert Contact Interface software.

At the System Manager:

To control a contact an Interface Action needs to be created on the System Manager and the State Change Method has to be changed to "Automatic, 2 states".

Example: Door Attendant

Features of OpenScape Xpert Terminals

Direct Keys

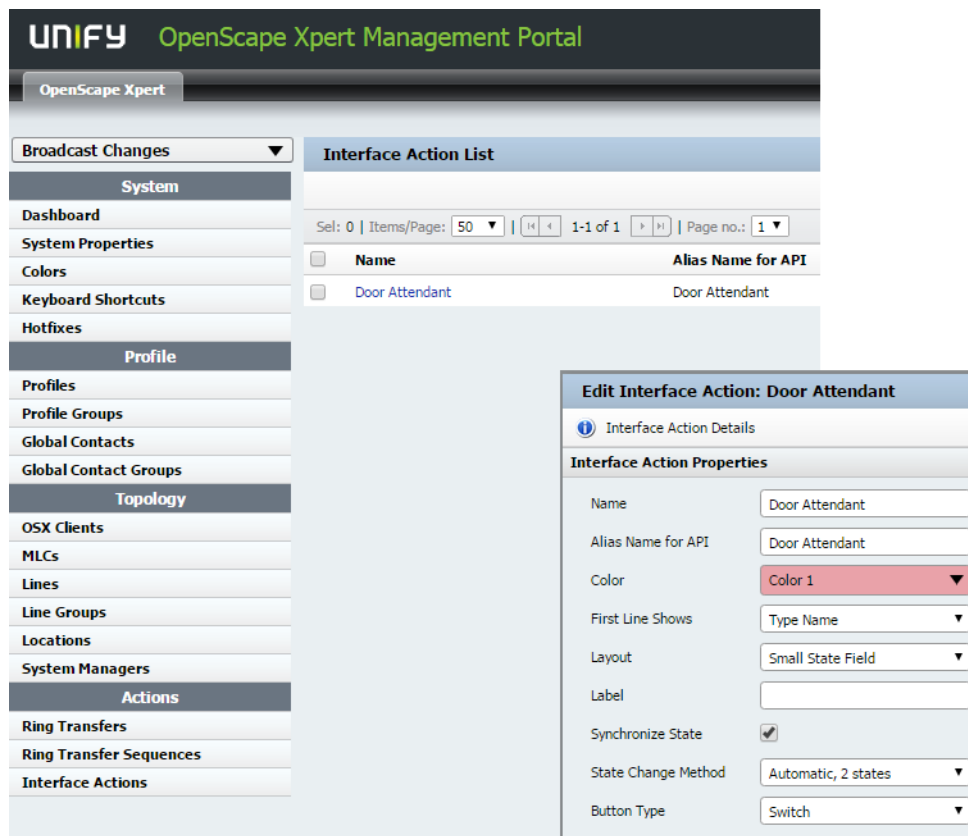

Pressing the Door Attendant key closes a contact and turns on the door lamp. Pressing it again opens the contact and turns off the lamp.

Pressing the "Do Not Disturb" key closes a contact, and turns on the display (e.g., Do Not Disturb) at the door. Pressing it again turns off the display.

The "Interface Action" function keys have a two-lines and a label. They can be configured at the System Manager or over the CTI interface.

Depending on the setting of the "Button Type" parameter the button can behave like a switch or a push button.

Display in the Status Line

If another user presses a CI key that is also present on the own OpenStage Xpert terminal, then the status change (CI Active or Inactive) is shown in the status bar. In addition, the name of the CI contact and the name of the remote profile where the key was pressed are displayed.

3.6 Direct Keys

A direct key (analogous to a speed-dial key) is used to store the call number of the destination station and to assign a "precedence line". Both external and internal phone numbers can be programmed on direct keys.

Direct Key Automatic (DKA)

In the idle state, only the name of the partner is shown on a direct key. As soon as the key is pressed, the line number and status are also displayed.

If the precedence line is busy, the system automatically searches for a free line.

Dialing occurs on the precedence line. If this line is busy, another line is used.

In the case of an incoming call, the calling party, if stored on a DKA button, is displayed together with the stored text and call processing signaling status. This so-called "re translation" function can be enabled or disabled at the System Manager.

Functions

- Signaling
- Enter new destination for DKA button
- Change destination for DKA button
- Change precedence line for DKA button
- Connection setup with DKA when precedence line is free
- Connection setup with DKA when precedence line is busy
- Connection setup with DKA as suffix dialing
- Answer DKA call

Availability indicators

The DKA can indicate the target's availability state in two different ways. The busy indication shows the user's profile status and the presence indication shows the destination line status.

- Busy indication: If the system administrator has enabled the busy indication for a direct key, a small square is displayed at the top left of the user name indicating the whether the user is available (green), on a call (red), or offline (gray).
- Presence indication: If the system administrator has enabled the presence indication (CSTA monitoring), in the idle state a small circle is displayed at the top left of the user name indicating whether the DKA target line is available (green) or busy (red). If the presence status is unknown, nothing is displayed.

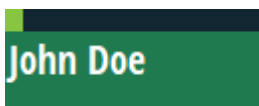
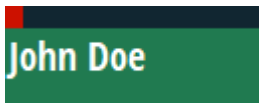
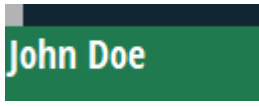
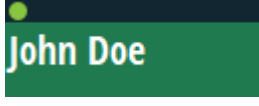
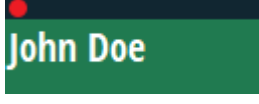
Icon	Status
	Busy indication: The user is logged in with profile configured for the DKA by the system administrator and he/she is available.
	Busy indication: The user is logged in with profile configured for the DKA by the system administrator and he/she is in a call.
	Busy indication: No user is logged in with the profile configured for the DKA by the system administrator.
	Presence indication: The destination number configured for the DKA is available.
	Presence indication: The destination number configured for the DKA is in a call.

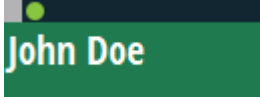
Icon	Status
	<p>Presence indication: The user profile configured for the DKA by the system administrator is offline.</p> <p>Busy indication: The destination number is available.</p>

Color Settings for DKA

In order to provide the user with a quick overview of his or her lines, the DKAs and the tabs of the line keys can be differentiated by color. The user selects the color for a line or DKA button (applies system-wide) from a palette of twelve colors. The twelve selectable colors are predefined by the System Manager administrator (based on 256 bit color mode). To highlight the own private line (default line), a separate color attribute is assigned to this line.

The color of the line is shown on the "tab". The advantage here is that the color for the line appears in

- the call control field,
- on the programmed DKA,
- in the call queue,
- and on the SPM channel key.

Example of color settings for DKA buttons in the System Manager (DK colors for OpenScape Xpert terminals).



Direct Key Manual (DKM)

A DKM (Direct Key Manual) is a name key on which a text and a phone number or a phone number suffix can be stored. The name key shows the data of the user. Both external and internal phone numbers can be programmed on name keys (DKMs)

If no specific line is selected, the default line or some other free line is used.

Functions:

- Enter new destination for DKM button
- Change destination for DKM button
- Connection setup with DKM
- Connection setup with DKM and suffix dialing
- DTMF suffix dialing

Features of OpenScape Xpert Terminals

Dynamic and Static IP Addresses

Color Settings for DKM

As in the case of DKA buttons, colors can also be set for DKM buttons. A total of 12 colors can be predefined at the System Manager. These 12 color definitions and the sequence in which they are displayed at the OpenScape Xpert terminal are the same as for DK button types. For details on the color settings and display, see Direct Key Automatic (DKA)

3.7 Dynamic and Static IP Addresses

Using DHCP, it is possible to assign IP addresses dynamically to the PC of the OpenScape Xpert client as well as the OpenStage Xpert 6010p/Mitel Xpert 6020p.

3.8 Open Listening

The "Open Listening" function key enables other individuals in the room to hear the remote partner via the loudspeaker. The status is displayed optically on the function key itself and in the call control field.

Functions:

- Activate Open Listening during a call
- Activate Open Listening and automatically seize default line
- Deactivate Open Listening (disconnect call with Disconnect key)
- Deactivate Open Listening and continue call with handset

3.9 Encryption at the OpenScape Xpert Terminal

The voice connection of the OpenStage Xpert V3711 terminal via IP is encrypted using the Secure Real-Time Transport Protocol (SRTP) as per RFC 3711 (IETF Standard) and is protected against eavesdropping. The encryption system uses the Advanced Encryption Standard (AES). SRTP is the extension to the Real-Time Transport Protocol (RTP).

The decryption of voice data is implemented using Pre-Shared Keys. The signaling of the OpenStage Xpert terminal via IP is a proprietary protocol and is not encrypted.

3.10 Freely Programmable Keys

Up to 200 pages (operation levels; optionally 200 pages) can be created in the user profile. The 201-st page is the logout and Receive Calls Only screen.

All pages can be freely configured, i.e., 40 to 60 line, destination or function keys can be freely programmed per page, split into 4 to 6 columns with 10 keys each. Graphical status signaling occurs on line, destination and SPM keys. This includes the automatic transfer of destination key labels or a Contact on to the line key of the seized line..

To increase transparency, the individual pages can be assigned names, and previously assigned names can be edited.

The system administrator can create up to 200 pages with 40 or 60 keys.

The Main Work Page can be freely defined.

The call control field and the call queue are always visible on the pages with 40 keys. On pages with 60 keys, the call control field and the call queue of a key (ControlField) can be enabled or disabled in the tool bar.

Functions

- Scroll to desired Desktop page
- Direct navigation to Desktop page
- Edit name of key page
- Edit Main Work Page
- Direct navigation to Main Work Page

This feature enables the OpenScape Xpert terminal user to configure his or her key assignments as desired.

Functions:

- Generate new keys (DKA, DKM)
- Copy keys
- Move keys (to same or any page)
- Delete keys

Using the functions listed above, the user can copy the keys that he or she uses most frequently to every page (e.g., Dialpad and SPM module). Please note, however, that the copied keys are treated as duplicates, i.e., any changes made to the attributes of a duplicated key will apply to all duplicates!

All line and function keys, except for the last of these keys in the user profile, can be optionally deleted. It is not possible to delete the last line or function key.

The administrator can assign certain keys with a so-called lock attribute to prevent them from being deleted or moved by the user of the profile. Only copying is permitted in such cases.

3.11 Saving or Refreshing User Profile

Changes made by the user at the OpenScape Xpert terminal are immediately and automatically stored in the database of the System Manager. The current status is displayed to the user in the status bar and via the menu button and a message in the Menu window.

Description

If the data connection to the System Manager is interrupted, the user can continue working with his or her terminal device. The user can also continue to make changes to his or her user profile, since these changes are cached in the terminal (queuing). When the data connection to the System Manager is subsequently restored, the terminal will sequentially store the changes made by the user in the database, provided the data version of System Manager database has not changed in the meantime.

Features of OpenScape Xpert Terminals



Number of Keys per Profile and Page

Status Indication in the Status Bar

The status bar shows various status messages (information, warning, error, help, question, etc.) from the application (on the picture there is an incoming call), connection status to the SM (the green led), the save job state icon and the date/time.



Status Indication in the Tool Bar via the Menu Button

Menu button	Meaning
	No changes are available. The profile is up-to-date. No further action is needed.
	The user changed the profile, but it cannot be saved to the database for an unknown reason. An attempt will be made to save the changes again. There is a 5 seconds delay in order to avoid a flashing display.
	The user has to refresh the profile because of one of the following events: The system administrator made changes to the user profile. The OpenScape Xpert terminal user can still make changes, but these will be discarded after the release of the system administrator's data. The administrator or another user changed the profile.

3.12 Number of Keys per Profile and Page

Pages with 40 and 60 keys per page are available to the user. In a 60-key page, the call control field and the call queue is replaced by two rows of buttons. For each page, the administrator can define whether it is a 40-key or 60-key page.

For pages with 60 keys, the user can show or hide the call control field and the call queue by pressing the "ControlField" button in the tool bar.

3.13 Dial Pad

The dial pad in the Phone or OpenScape Xpert Desktop can be used for manual dialing at any time. The dial pad is always shown in the Phone Desktop. In the OpenScape Xpert Desktop, it can be optionally enabled or disabled via the tool bar.

Functions:

- Show dial pad manually
- Hide dial pad manually

- Enter call number: after a timeout, the number is automatically dialed on the precedence line
- Enter call number and press the "check mark" button: the number is automatically dialed on the precedence line
- Enter call number and select a line in the idle (unused) state: the number is dialed on the selected line
- Select line in the idle (unused) state and enter call number: the number is dialed on the selected line after a timeout or on pressing the "check mark" button.
- The dialog button < deletes the last number entered.
- The dialog button C deletes the last number entered from the command line
- DTMF suffix dialing
- The time after which the entered digits are dialed automatically (timeout) can be set at the System Manager individually for each subscriber (0 ... 30 seconds).

The following figure shows the dial pad that is opened with the 5th menu button on each page. The dial pad can also be programmed at a fixed location on one or more pages.



3.14 Disconnect

One or more connections can be disconnected simultaneously.

Functions:

- Replace handset
- Disconnect function key
- Disconnect key for each handset individually
- Loudspeaker key
- Logout
- Receive Calls Only
- Disconnect all Connections
- Kill Line

3.15 Graphical User Interface

The OpenScape Xpert user interface is presented with graphical elements as a full screen (full screen mode) or as a window (window mode). Due to the use of graphical status displays and controls, the system is almost self-explanatory. The operation allows to change in the maintenance mode, and thus enables quick and easy operation of the application.

User Interface

The following figure shows the user interface of the OpenScape Xpert Client.



3.16 Call Control Field (Speech Units)

The call control field shows the status of the speech units.

Overview

The first speech unit on the picture below is the Handset, the second is the Headset, the third is the Microphone with speaker and the fourth is the Microphone without speaker. The speech unit icon shows the loudspeaker and the mute state.



Signaling

- Selected speech unit
- Name and number (if transmitted by the PBX)
- Used line
- Handset status (off hook or on hook)
- Mute/Talk on handset
- Open Listening on/off on handset
- Voice recording "Active / Not Active" on handset and handset microphone

NOTICE:

Calls can be conducted on the same line on multiple speech units, e.g., handset 1 and handset 2 (parallel calls at OpenScope Xpert terminal)

Maintenance Mode for the Call Control Field

Due to the usability improvements from OpenScope Xpert Version 5R1 on, the maintenance mode is available for the Call Control field.



In every row the following icons appear (from left to right): Disconnect icon, Hold icon, Add/Remove to/from SPM icon, Add to Contacts icon, Handset Properties icon.

- Disconnect icon: disconnects the call on the specified speech unit.
- Hold icon: puts the call on hold on the specified speech unit.
- Add/Remove to/from SPM icon: Adds the call to a free channel of an SPM unit.

If the call already exists on an SPM unit it removes the call from the SPM unit.

- Add to Contacts icon: adds the partner's telephone number to the Contacts.
- Handset Properties icon: opens the Handset Properties dialog.

Automatic assignment of speech unit

If a handset is lifted off the cradle (cradle off hook), the selection in the call control field automatically switches to the handset.

Manual assignment of speech unit

A speech unit can also be selected manually by pressing its display field.

Selecting the handset in the Contacts directory

If dialing is initiated from within the Contacts, either the off-hook handset or the handset selected last before entering the Contacts is used.

Fixed assignment of speech unit

You can assign one of the four speech units directly to a line so that the predefined speech unit is used whenever that line is seized. If the line is not associated with any of the four speech units, the currently selected speech unit is used.

NOTICE:

The Comfort Activation works the same: the calling line "Top of Queue" is always seized with the off-hook speech unit. A parallel call with a second speech unit of the same terminal is likewise possible in this case as well.

If the appropriate line is already in use on dialing with the dial pad, DKA, DCM, LNR or SNR, the next free line from the same line group is used. If the original line is assigned to a speech unit, the next free line from that line group with the same speech unit assigned to it is seized.

As far as possible, the system administrator should ensure that all lines of a line group have been assigned the same speech unit.

If a line has been assigned a specific speech unit, the appropriate speech unit is signaled on the tab. This applies to all keys assigned to a line with an active line tab (DKA, SPM and call queue). For seizure types in which the precedence line is not necessarily seized (DKA and LNR), the assigned speech unit (if not the "current" one) is signaled on the corresponding button. This signaling is also active in the idle state.

When dialing from the Contacts, the selection is reduced to the configured speech unit. In the call memory (call journal), the speech unit associated with the selected entry can be signaled in a separate window (e.g., with the Dial button).

System Manager example: the line New York has a fixed assignment to handset 1, and the line Tokyo is assigned to handset 2.

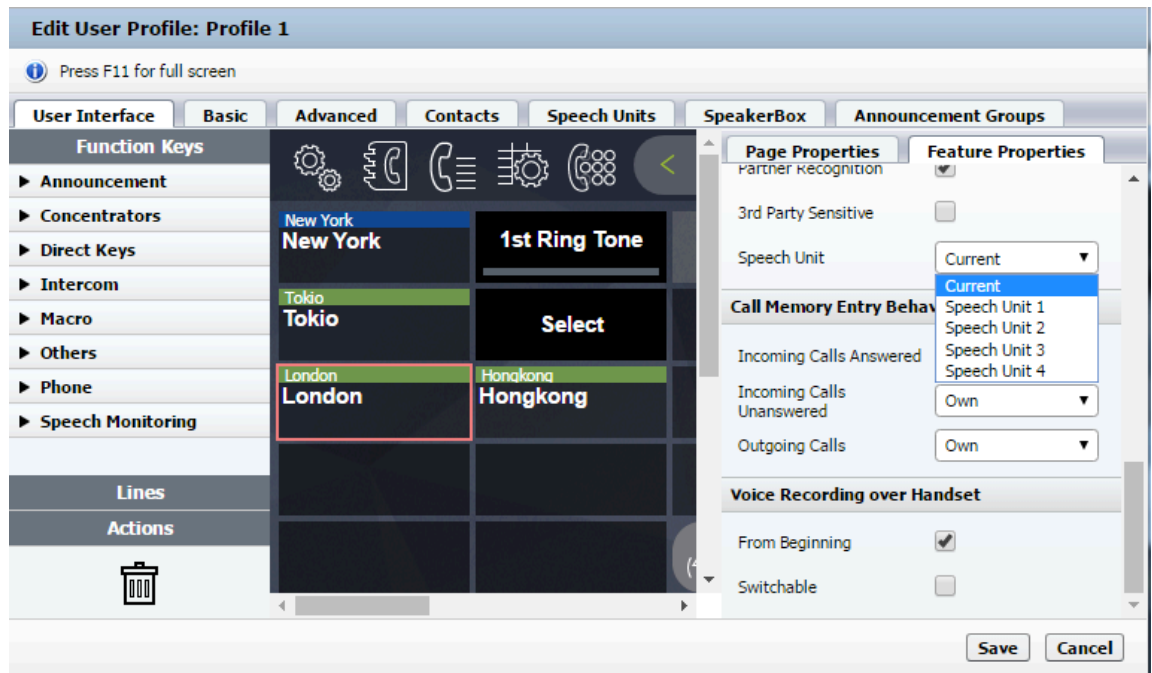

3.17 Muting the Handset Microphone

The Mute function key switches the handset microphone for the selected handset off or on.

Functions:

- Turn off Mute (handset call muted)
- Turn off Mute (handset call)

3.18 Kill Line Function Key

"Kill Line" is used to disconnect lines that were not disconnected by users.

"Kill Line" can be used to force a disconnect, regardless of whether or not some other user is still talking, the line is on hold, speech monitoring is enabled, etc.

3.19 Using the Mouse and Keyboard (Short Cut)

It is possible to use an external PC keyboard and a mouse.

3.20 Progress Indicator at the Terminal (Progress Control)

When the user at the OpenScape Xpert terminal initiates an action that requires several seconds of processing time, familiar icons (hourglass and progress bars) are used to indicate that the system is busy.

Hourglass (< 5 s)

In accordance with the Microsoft Style Guide, the hourglass is linked with the cursor. No entries are possible when the hourglass icon is being displayed.

NOTICE:

If the cursor display is turned off, the hourglass display is also dropped.

Progress Control (> 5 s)

Whenever possible, a Progress Control is used for long-lasting operations. If this is not possible, an Active Control is displayed.

Active Control (< 5s)

For short operations, an Active Control is displayed.

Displayed in the status bar. The black block moves back and forth.

The hourglass is additionally displayed in both cases.

Busy signaling is available for the following actions:

	Time estimatable	Progr. Control and hourglass	Active Control and hourglass
Login of a profile	no	no	yes *
Loading of a profile	yes (relative)	yes	no
Opening call memory	yes	no	yes
Opening the Contacts	yes	no	yes
Opening the call queue	yes	no	yes
Synchronous DB access	no	no	no
Macro	yes	yes *	no
Opening the Contacts	yes	yes *	no

* without hourglass

3.21 Hold and Private Hold

The "Automatic or Manual Hold" function exits a call without disconnecting. The call is placed on hold in the call queue until it is picked up by another user or resumed by the same user. Private hold puts a call on hold for a later retrieval by the same user.

Depending on the configuration of the line, the system automatically places a connection on hold in one of the possible hold states. The status indicators for line keys, direct keys and call queue queues show the current hold state.

Automatic Hold

Accepting another call on the same handset or dialing another user causes the current call to be automatically placed on hold.

Manual Hold

A call can be placed on hold "manually" by pressing the **Hold** key or the **Private Hold** key. This call then appears in the call queue. The data of the party on hold is deleted from the display of the handset key.

Functions

- Signaling
- Hold with general Hold key
- Hold with assigned Hold key
- Automatic hold
- Place speech-monitored line on hold
- Hold with Disconnect key
- Place dedicated line on hold
- Private Hold with **Private Hold** key.

Hold Behavior when Using the Hold Key

There are two different types of hold using the **Hold** key which are configured in the System Manager for shared (common) lines:

Common Hold or Private Hold:

- Common Hold: when the last user disconnects the line, the connection is cleared, and the green optical signaling shown on the line key for the line on hold is turned off.
- Private Hold: only the user who first placed the line on hold can disconnect the line. "Private Hold in Call Queue" is not possible here, i.e., there is no display in the call queue of other users. .
- If the parameter "Privacy on Private Hold" is enabled for this line, then other users who also have this line cannot enter (i.e., pick up) the held line.

Hold Behavior when Using the Private Hold Key

The **Private Hold** function key introduced in OpenScape Xpert provides the same functionality as the **Hold** function key when the Hold Behavior 'Private' is set for the line.

Features of OpenScape Xpert Terminals

The call can be simply put away for a later retrieval by the same user and can be put on hold to be retrieved by another user in the same session.

Common Hold in Call Queue/Concentrator

For each line and profile, a setting can be made in the System Manager to determine whether or not a line in the "Common Hold" state should be signaled in the call queue (default: no).

If the check box is enabled, whenever a line is placed in the "Common Hold" state by a user, the held line will (always) be signaled in the call queue of at that user as well all other users who have configured that line accordingly. When a user enters (i.e., picks up) the line on Common Hold, the entry in the call queue of all OpenScape Xpert terminals is removed.

INFO:

Common Hold is signaled on the line keys and in the call queue.

Page Properties	Feature Properties
Edit Settings	
Pinned	<input type="checkbox"/>
Changeable	<input checked="" type="checkbox"/>
Call Signalization	
Call Queue Entry / Concentrator Active	<input checked="" type="checkbox"/>
Ringing Active	<input checked="" type="checkbox"/>
Cradle Active	<input checked="" type="checkbox"/>
Ringing Type	Ringing 1 ▼
Common Hold in Call Queue/Concentrator	<input type="checkbox"/>
Call Queue Priority	Low ▼
Prefixes	
Use Prefix	Local Line Prefix ▼
Default Prefix	<input type="text"/>
Alternate Prefix	<input type="text"/>
Call Behavior	
Suppress Call Forward	<input type="checkbox"/>
Preferred Identity Number	<input type="text"/>
Intercom	<input type="checkbox"/>

3.22 About Window

The About window shows the version number of the software, device name and the currently logged in profile of the OpenScape Xpert terminals.

3.23 Redial Number

The "Redial" feature can be used to automatically call the last dialed number again or the number saved in the redial memory. "Redialing" via the Call Memory (call journal) is described in the Call Memory section.

Last Number Redial (LNR)

This sets up a connection with the last dialed number (LNR = Last Number Redial). The number of the last dialed user appears on the LNR key.

The OpenScape Xpert terminal automatically stores the number and line of the last dialed user. If this line is busy when dialing, the OpenScape Xpert terminal uses another line.

Functions:

- Set up connection with LNR
- Set up connection with LNR followed by suffix dialing

Save number in redial memory (SNR)

After dialing a number, this number can be directly saved in the redial memory (SNR). The connection is established via the SNR (Saved Number Redial) key, which shows the call number of the user.

If the number of an active outgoing connection was saved, then the line of that connection is used on redialing. If this line is busy when redialing, the OpenScape Xpert terminal uses another line.

If the number was saved during an active incoming connection, the OpenScape Xpert terminal uses the precedence line of the saved number when redialing. If this line is busy, the terminal uses the next free line.

Functions:

- Save STNO (station number) of an incoming connection (SNR)
- Set up connection with SNR (outgoing connection)
- Save STNO (station number) of an outgoing connection (SNR)
- Set up connection with SNR (incoming connection)
- Set up connection with SNR and suffix dialing

3.24 Login

After the login, the system automatically loads the user profile on the Xpert OpenScape terminal. Any user can log in system-wide at a terminal; the user's personal profile is always loaded at that terminal.

The available profiles (name of the profile) are offered for selection when logging in.

Features of OpenScape Xpert Terminals

Logout

Function when logging in the profile:

On starting up the OpenScape Xpert terminal, the Login window appears. The "Logged In..." button can then be used to check whether and at which workplace the selected profile has already been loaded.

Functions:

- Login
- Free seating
- Change login (other profile)
- RCO - Receive Calls Only - page

Multiple Login

The "Multiple Login" parameter can be set in the profile properties (Basic tab) to define whether or not the profile can be logged in at multiple terminals (maximum all). The parameter can be enabled and disabled. The parameter is disabled by default. The programming is handled in the System Manager:

The setting of the "Multiple Login" parameter is not displayed on the profile and cannot be changed by the user.

3.25 Logout

The "Logout" function is used to log off the OpenScape Xpert terminal at the system. This prevents unauthorized individuals from setting up connections at a terminal and having access to the Desktop interface.

Logout

All connections at the OpenScape Xpert terminal are cleared. The Login window in which only the existing Direct Keys and handset 1 can be used for dialing (Logout page) appears. Any employee can log in again at the system (free seating) with his or her profile.

Ring Transfer and Keep Alive Setting

When logging out from a terminal on which ring transfer keys are still active, a warning message appears indicating which ring transfer keys are still active on the device.

If the subscriber is the last user receiving the calls, he or she cannot log out. Before logging out, the user must ensure that this number remains accessible.

Functions:

- Login
- Dial, e.g., an emergency number
- Receive Calls Only (RCO), i.e., accept calls when a dialing block has been enabled

Scheduled Logout

The "Scheduled Logout" feature prevents unauthorized use of the OpenScape Xpert terminal and OpenScape Xpert and releases all lines seized from that terminal.

With the "Scheduled Logout" feature, all OpenScape Xpert terminals are placed in the logged out state every day at the same time. A corresponding optical and acoustical signal notifies the user that his or her terminal will be logged out soon (in 1 min). The user can then reject the "scheduled logout" to continue working. The user can also log in again at any time.

The logout time, which applies to all terminals of the system, is set by the system administrator at the System Manager. This function can be disabled. By default, no timed logout occurs.

NOTICE:

It is not possible to place an OpenScape Xpert terminal in Receive Calls Only mode via a schedule.

3.26 Macro Key

The user of an OpenScape Xpert terminal operates a macro key (e.g., macro XYZ). The macro button points to a page with the name XYZ, where the macro functionality is stored. On this page, the keys are processed in a predefined order.

- Each macro uses one of the 200 available pages.
- A maximum of 60 macro steps may be included in a macro. The number of macro steps depends on the number of keys per page.
- Macros can be chained. By chaining macros, more than 60 steps can be saved under a macro.
- However, the user or administrator must ensure that the macros do not run in a loop (where macro 1 calls macro 2, which again calls macro 1, for example)
- A macro runs sequentially until the first empty key or the end of a page.
- A progress indicator in the status bar shows the progress of the macro execution.
- A running macro can be terminated with the "Escape" key (on terminals with keyboards).
- The macro label is the page name of the page where the macro is stored.
- The name of the macro page, and thus the name of the macro, can be edited by the user.
- A macro may contain all keys that can be placed in any one of the 40/60 available positions. (LK, FK, DKA, DKM).
- The following keys were implemented especially for the macro functionality:
 - – Logout
 - – Delay 1s
 - – Delay 10s

The following functions cannot be used in a macro:

Features of OpenScape Xpert Terminals

Menu Buttons on the Main Tool Bar

- All tool bar buttons
- SPM channel keys (SPM announcement/extension key)
- Dialpad (digits can be stored after DKM)
- Call Queue
- Variable announcements
- Group announcements
- Announcement at SPM A-D
- Market line
- Reported configurations
- Web interface
- Volume Control Key (Intercom)

Functions:

- Create macro page (SM)
- Configure macro key (SM)
- Edit macro (SM and terminal)
- Delete macro (SM and terminal)
- Run macro (terminal)
- Edit macro name (SM and terminal)
- Show or hide the text "Macro" on a button (SM)

Editing macros at the OpenScape Xpert terminal

Users at a terminal can edit macros themselves by using the Copy, Move and Delete Key feature, but are not allowed to create them.

To prevent a terminal user from changing a macro, the macro pages can be hidden for the user.

Macros are also used for custom button functions. In certain cases, it may not be desirable that the function running in the background is identifiable on the key label. For this reason, the display of the text "Macro" can be switched on or off via the System Manager.

Macro Delay Key

Two Delay keys with delay intervals of 1 and 10 seconds, respectively, are available for insertion into macros.

3.27 Menu Buttons on the Main Tool Bar

OpenScape Xpert offers you several convenient menu buttons with which you can quickly operate the terminal.

The tool bar contains buttons to access different common functionalities. The following menu buttons appear (from left to right) and can be activated:



- Settings Menu
Log out, General Settings and Help

- Telephone Directory
Personal (local) and system-wide (global) phone directory
- Call Memory (Call Journal)
Call Memory of incoming and outgoing calls
- Maintenance Mode
Changes to the Maintenance Mode. The Maintenance Mode replaces the former "Right Mouse Button" which opened a context menu.
- Dial Pad
Show or hide dial pad
- Page Selection widget
Use the **Previous** or **Next** button or the selection list to select a page.
- Control Field
Show or hide call control field for speech unit and call queue
- Quick Conference
Starts a conference call.
- Defaultor Home Page
Changes to the default page, e.g. the phone desktop
- Back to previous page
Switch back to previous page
- Online Help
Start Online Help

NOTICE:

The toolbar icons may deviate from this set of icons depending on the mode and individual settings.

Menu buttons can be changed to "Go To Page" function keys#

Locking menu buttons

The menu buttons can be locked for the user individually by the system administrator.

Locked menu buttons are grayed out.

3.28 Simultaneous Lines per OpenScape Xpert Terminal

The number of possible lines and non-blocking cut-through connections depend on the following factors:

- OpenScape Xpert components and topology
- IP network components and topology
- SIP PBX components and topology
- Gateway components and topology

For more details on project planning and the component requirements, refer to the Project Planning Guidelines.

Features of OpenScape Xpert Terminals

"Go to Page" Function Key

The OpenScape Xpert user profile can be set up with the following voice devices:

Unit	Minimum	Maximum
Handset speech unit	1	4
Speech Monitoring LS à 4 Channels	0	6
Speech Monitoring Channels	0	24

This means that up to a total of 28 voice lines can be switched through concurrently at a terminal (number of handsets and number of speech monitoring channels). All correspondingly configured lines are signaled on the terminal.

3.29 "Go to Page" Function Key

In contrast to most of the other function keys, the "Go to Page" function can be set up by the administrator on a menu button as well.

To simplify navigation, the user is provided the option to return to the last viewed page by pressing the BackToPreviousPage button on the tool bar.

Page Signaling parameter

If the "Page Signaling" parameter has also been activated, the "Go to Page" function key is signaled in red when a line on that page is in the call state.

Hiding the "Go to Page" Label

The "Go to Page" text can be optionally shown or hidden per key.

3.30 Pages

Each user profile can be optionally assigned from 2 to a maximum of 200 pages. Every page may optionally include 40 or 60 keys with freely programmable key fields.

Hidden Pages

Function

From a total of up to 200 pages plus the home page (default page), most are used for normal purposes by the subscriber. There are, however, some pages that are used for macros and management functions. Such pages can be hidden from the telephone users to avoid accidental changes and enable a better overview.

The administrator can mark a page as "hidden" for a user profile in the System Manager. Thus, the user does not see this page. Such pages are not listed in the page selection, and the next visible page appears when you scroll with the "Next" button.

- A "Go To" button cannot point to a hidden page.

- The home page cannot be hidden.

3.31 Receive Calls Only

The "Receive Calls Only" function is used to prevent unauthorized individuals from using or accessing the OpenScape Xpert terminal.

Emergency calls can, however, always be made from every OpenScape Xpert terminal via fixed programmed Direct Keys using handset 1. Incoming calls can be answered via handsets 1 - 4 at any time if the "comfort activation" function has been enabled for the handset for the incoming line.

Any employee can log in at the system with his or her profile (free seating) and thus log out the existing profile.

Functions when Receive Calls Only is Activated

- Cancel (i.e. unlock) Receive Calls Only
- Accept incoming calls (with "comfort activation" enabled).
- Dialing using displayed DSS keys / emergency calls
- Log in as a different user

3.32 Ring Tone (Ringer)

For each line key, a ring tone can be selected from eight different ring tone melodies, and the signaling of incoming calls can also be switched off if required. The volume of each ring tone can be changed collectively for the OpenScape Xpert terminal.

Functions:

- Call settings for lines
- Test call settings (test call)
- Set volume
- Ring Tone On / Off
- Turn ring tone on or off during ringing call (Ring Tone On/Off button)

Ring Tone Settings During a Conversation

The ring tone can be set for incoming calls in the call state at both the OpenScape Xpert System Manager and the OpenScape Xpert terminal.

The following settings are possible:

- Ring Tone (default)
Ring tone, as defined in the "Line Properties".
- Special tone
Special tone (once, 3 "beeps") - this tone cannot be changed.
- Off
No ring tone.

Features of OpenScape Xpert Terminals

Ring Transfer, Ring Transfer Sequence, Sequence Exclusive Group und Keep Active Group

These settings depend on the "call queue priority" of the line on which the incoming call is waiting:

- Higher – The line of the call at the topmost position in the call queue has a higher line priority than those on which calls are currently being conducted.
- Equal – The line of the call at the topmost position in the call queue has the same line priority as one of those on which calls are currently being conducted.
- Lower – The line of the call at the topmost position in the call queue has a lower line priority than all those on which calls are currently being conducted.

First Ring Tone Function Key

The First Ring Tone function key enables the user to change the acoustic signaling for lines with low and normal call queue priorities from the regular ring tone (default) to an irregular ring tone. The irregular ring tone consists of only one ring tone melody and can only be heard once at the start of an incoming call (first ring).

3.33 Ring Transfer, Ring Transfer Sequence, Sequence Exclusive Group und Keep Active Group

The function keys Ring Transfer, Ring Transfer Sequence allow convenient operation of OpenStage Xpert.

Ring Transfer (RT) Function Key (FK)

The Ring Transfer function key can be used to enable or disable the ring tone for one or more lines at the own terminal or for another terminal. The function key can be used by one or more users.

The "Ring Transfer" function key can be set up for each profile at the System Manager. For each Ring Transfer action the lines can be defined, for the Ring Transfer function key, the partner profile to which the function key refers can be defined.

It can be configured that after user logout the RT keys controlling lines on the logged out profile are displayed as inactive by remote users, and cannot be activated.

Ring Transfer with Keep Active setting

When the RT is configured to keep active, the system will make efforts that at least on one profile the lines configured on the RT are always ringing. The system checks this in two cases:

- If an attempt is made to deactivate the last Ring Transfer function key of a Keep Active RT the following message appears in the status bar of the OpenScape Xpert terminal: "The last active action in a Keep Active Group cannot be deactivated."

- When the user logs out, but the logout would cause that the RT is not active anywhere, a warning message appears indicating which ring transfer keys are still active on the device.

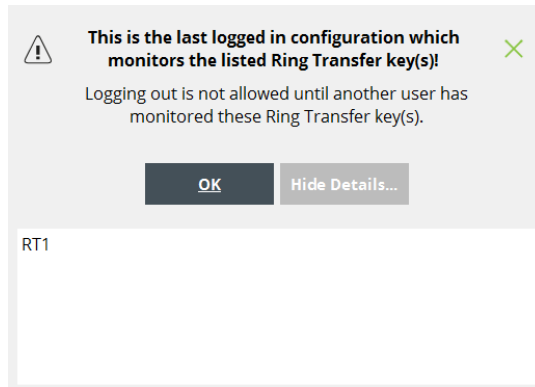

If the user has the “Allow Logoff if Ring Transfer Is Active” setting set on his profile. He is allowed to log out after the warning message even the all RTs will be inactive.

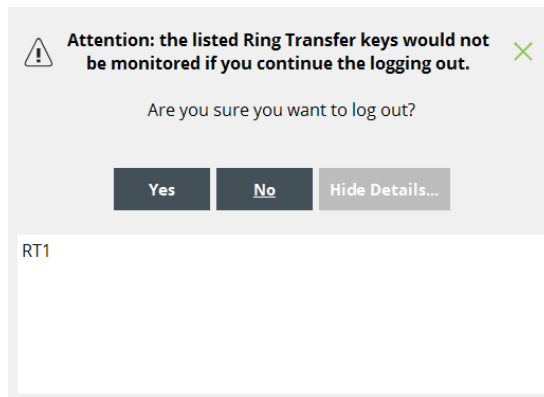

Function of the Ring Transfer at the OpenStage Xpert Terminal

The user interface does not show to which lines the ring transfer applies. The key can be moved, copied and deleted (except for the last key). The user cannot set up any new Ring Transfer function key or even edit the functionality of an existing function key to configure a further line key for the ring transfer, for example.

To enable the user to see that a ring transfer has been activated, the status of the ring transfer is displayed in the line properties.

This has no effect on the optical signaling.

As a prerequisite for the ring transfer, the acoustical ring must be turned off on the appropriate lines. If "Display in Call Queue" is not set for the profile, the acoustical ring cannot be activated by the Ring Transfer function key.

When a profile logs in, the last status of the "Acoustical Ring Transfer" function key is displayed and set. When a profile logs in for the first time, the ring transfer is deactivated (the acoustical ring is turned off).

If the "Ringer 'off'" function key is activated, no ringer is enabled for all configured lines, regardless of the status of the Ring Transfer function key.

Ring Transfer Sequence (RTS) Function Key (FK)

Multiple Ring Transfers (RTs) can be assigned to a Ring Transfer Sequence (RTS), and it is also possible to define whether or not these RTs are activated. On activating the RTS key, these RTS are either activated or deactivated, depending on the setting. The relevant RT is not needed to be present on the profile. As in the case of an RT, an RTS can be switched remotely.

The Ring Transfer (RT) and Ring Transfer Sequence (RTS) functions can be controlled remotely via the new API interface of the open communication solution for the OpenScape Xpert system.

3.34 Languages

OpenScape Xpert offers multiple languages for the user interface of the terminal.

The following languages are available in OpenScape Xpert:

OpenScape Xpert	Languages
User interface and function keys	German English French Czech Slovak Polish Russian Italian Portuguese Spanish Hungarian Chinese-simplified (Mandarin)
Online Help and User Manual	German English Spanish Russian For the other languages, the English online help is displayed.

NOTICE:

From OpenScape Xpert V5 on, the Spanish language is supported on the OpenStage Xpert Speaker Module.

3.35 TAPI Interface for Third-Party Applications

The TAPI interface (TSP V2.0) enables other applications to control OpenScape Xpert terminals either directly or via a LAN and/or to receive call states and data.

This makes it possible to achieve better integration of the OpenScape Xpert terminals and application in the workflow of a user (e.g., by using Microsoft Exchange or Outlook). Using the TAPI interface, standard telephony functions can be used at the user's own PC or even at another PC via a LAN.

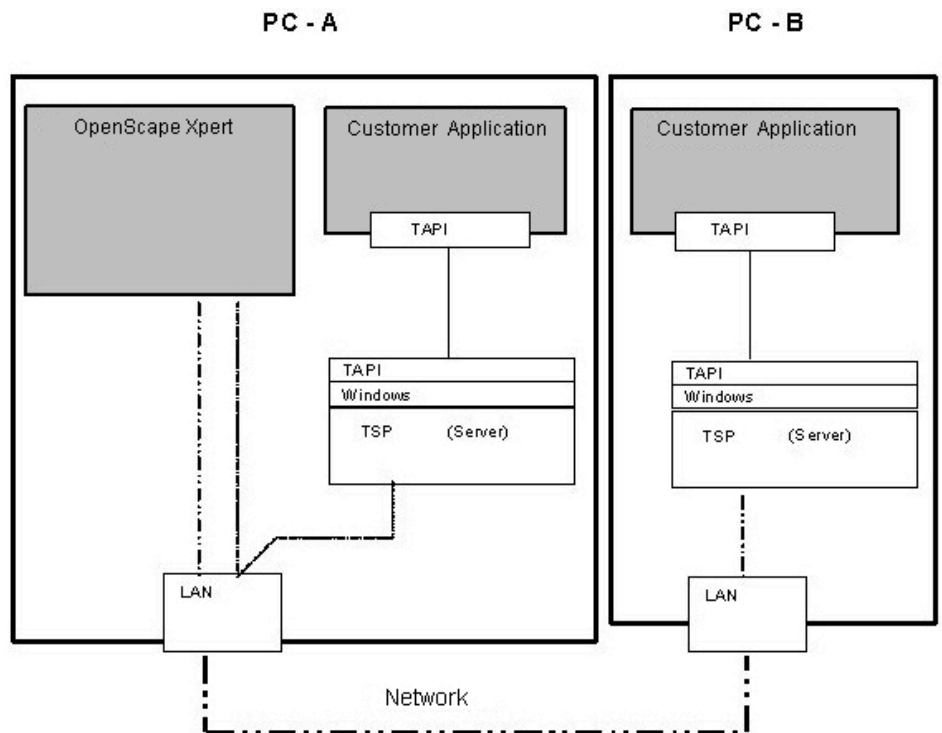

3.36 Web Interface

The OpenScape Xpert Web Interface enables the user to display up to five third-party web applications and control them via the LAN and the HTTP/XML protocol.

NOTICE:

Please note that Internet applications can cause a significant degradation in the performance of the terminal, depending on the system and the hardware. Please contact the Product Management for more information.

The Web Interface extends the integration of the OpenScape Xpert terminals and the OpenScape Xpert application in user workflows, e.g., through voice recording and the search and replay function.

Features of OpenScape Xpert Terminals

The following settings are possible:

- Change size of browser window
- Display scroll bars of window (on/off)
- Display navigation bar (on/off)
- Fixed Uniform Resource Locator (URL)
- "Home" function (back to predefined URL)
- "Soft Key" function to enter text and numbers (Display on/off)
- Multiple (identical or different) Browser function keys in the same user profile

The function is offered for the OpenScape Xpert application in Mouse and Touchscreen user interface.

The web application of the third-party vendor must meet the general requirements of the OpenScape Xpert Application Interface and should be presented with the same "look&feel" as an OpenScape Xpert component.

- This includes: Size of window and ease of use
- Used colors and test fonts / font size
- Operation optimized for touch screens and/or mouse
- Appearance and usage of buttons (look & feel)

Functions not supported:

- Predefined password by the administrator
- No direct input of URL by user
- Side filter (allow specified links)
- SSL Certifications
- FTP Protocol
- Copy and Paste
- Indication of a secure/not secure page
- Changing of text size and character coding
- Marking text and copy/paste within the browser and from/to the browser in to the optiClient desktop/dialogs
- Destination save as
 - Install and Execute executable destination file
 - Error Message when HTTP error
 - Pop-up windows
 - Cookies
 - Integrated Windows Authentication
 - News Ticker
- No zoom function to fit HTML pages into AI browser window
- – Browser Applet (Sun Microsystems Inc.)
- – SSV Helper (Sun Microsystems Inc.)
- – Media player (Microsoft, Real player,...)
- – Messenger (Microsoft, ...)
- – Live Meeting (Microsoft)
- – Office Controls (Microsoft)
- – Web Searches (Google, ...)
- – and all others.
- Proxy server

The design and integration of the OpenScape Xpert Web Interface provides for a wide range of different applications. Please note, however, that web applications have not been globally released, but can be certified on request.

No direct media streaming via the web interface (i.e., no plug-ins such as ActiveX, Shockwave, etc.) is allowed.

3.37 Telephone Directory

Every OpenScope Xpert terminal or profile has its own local phone directory. In addition, group phone directories can be created. These entries are the same on the terminals of the respective groups.

NOTICE:

A phone directory has no hard limit, but the client can handle only 24000 global entries in total.

The electronic telephone directory can be used to store phone numbers and names. Entries can be added, edited and deleted, etc., and calls can also be made by dialing directly from within the Contacts.

A new entry is created by

- entering the data of a subscriber manually,
- transferring the data of a subscriber (from a call) into the Contacts,
- transferring the data from the call memory (call journal) into the Contacts, or
- creating a DKA.

The Contacts can be protected against unauthorized access by a password. If password protection has been activated, an authorization prompt will be displayed on opening the Electronic Telephone Directory.

Functions

- Contacts Settings
- Contacts - Create new entry
- Contacts - Copy entry
- Contacts - Edit entry
- Contacts - Search entry
- Contacts - Delete entry
- From Contact - Create DKA (Direct Key Automatic)
- Set up connection from Contacts
- Set up connection from Contacts followed by suffix dialing
- Add user to Contacts
- Password protection

Global Telephone Directory

The profiles can be assigned to a profile group at the System Manager. Global contact groups can be assigned to profile groups. A profiles group can have multiple contact groups and a contact group can be added to multiple profiles groups. The global contacts of a profile group apply to all profiles configured in that group..

The user entries in the global Contacts can be created, edited and deleted only by the OpenScope Xpert administrator in the System Manager. The

Features of OpenScape Xpert Terminals

administrator can manage up to 6000 entries with name and number in the private contact. An OpenScape Xpert client can manage up to 24000 global contacts. An import of global contacts from an external CSV file is possible.

Configuration of Contact Group at the OpenScape Xpert Terminal

On starting up the Contact Group at the OpenScape Xpert terminal, the private Contacts is always presented first. Besides the private Contacts, it is also possible to select the global Contacts.

When searching for an entry (Search Entry), only the currently displayed electronic directory is searched for a matching entry.

If the OpenScape Xpert terminal user selects a directory entry from the global Contacts, the default line configured in each case or the already connected line is always used for dialing. The user can select the handset on which the dialing is to occur.

The function to "dial from the Contacts during an existing call at the current speech unit" (automatic consultation call) can also be executed for user entries in the global Contacts.

Global Contacts: The administrator can define at the System Manager whether or not users of the global Contacts can edit entries. If the "Global Contacts Changable" check box is enabled under Contact Settings at the System Manager, the users can edit the global Contacts.

Extended Contact Entries with two Additional Fields

To extend the Contacts, two additional fields are included for extensions in the database; this applies to both the local and global Contacts. The two fields are activated at the System Manager (e.g., Field 3: Department and Field 4: Job Title) and can be optionally displayed or hidden for each profile. The local Contacts can be created and edited by the users themselves. For the global Contacts, the administrator can define at the System Manager whether or not these entries can be edited at the OpenScape Xpert terminals (see also the presentation of the "Changeable" parameter above).

Field 1 shows the First Name and Last Name; Field 2 shows the phone number. Fields 3 and 4 could, for example, be used as entries for the Department and Job Title of the person to be called. Fields 3 and 4 are shown in the second line under the Name and Phone Number.

Partially Qualified Search in the Contacts (Global and Local)

It is also possible to perform a partially qualified search in the global and local Contacts. The user can search by Last Name (Field 1), First Name (Field 2), and Department (Field 3) or Job Title (Field 4), for example, by using either "contains" or "is".

3.38 Speech-Sensitive Signaling on the SPM

Speech Monitoring Control (SPMC) includes speech-sensitive signaling on the SPM channel key.

Up to four conversations can be located on a speech monitoring loudspeaker. A trader can have a maximum of 6 speech monitoring loudspeakers with a total of 24 channels. When a trader hears an offer from a speech monitoring loudspeaker, the optical speech-sensitive signaling on the SPM channel key can assist the trader in identifying the correct partner to conduct business with.

The optical speech-sensitive signaling on the SPM channel key appears at the start of a syllable in < 0.4s and persists after the end of the syllable for as long as is set at the System Manager.

The SPMC can be enabled and disabled at the System Manager for each SPM channel and profile.

SPM Time of Persistence

For each OpenScape Xpert profile, the SPM time of persistence can be changed. The range of settings varies from 0 to 10 seconds (only settings in seconds are possible) and applies to all SPM optical speech indicators for channels A1 through F4. The setting can only be made at the System Manager. Increasing the time of persistence gives the terminal user more time for the optical display when speech is sensed on the lines of the SPM channels.

3.39 Speech Monitoring (SPM)

The "Speech Monitoring" (SPM) feature enables users to follow calls or announcements via the SPM loudspeaker even when they are not actively involved.

The system administrator can set up 6 SPM modules at an OpenScape Xpert terminal. An SPM module has 4 SPM channels for speech monitoring. A maximum of 24 SPM channels are available for speech monitoring.

The profile of the existing lines on the OpenScape Xpert terminal with the individual channels of the loudspeaker occurs directly at the OpenScape Xpert terminal or via the System Manager.

The volume can be set independently per SPM module and SPM channel.

A line assigned to an SPM channel is called an SPM line. The assignment of a line to an SPM channel can remain active after closing a connection ("fixed" line assignment) or only for the duration of a call ("temporary" line assignment).

An SPM line is not a two-way call connection, but only a "listening connection". It is, however, possible to switch to the call state at any time.

SPM Mute

The playback of an SPM channel or SPM loudspeaker can be turned off without changing the volume settings.

NOTICE:

The system administrator can protect the assignment of a line to an SPM channel ("fix-protected"). This assignment cannot be deleted or changed.

The following functions are available:

- Set volume of SPM channels and of the SPM loudspeaker
- Assign a line to an SPM channel (the same line can only be assigned to one channel of the same system)
- Switch between speech monitoring and two-way call
- Change SPM assignment
- Delete SPM Assignment
- Save/Load SPM Assignments
- Disconnect SPM Lines (SPM Disconnect key)

If the line is in the "idle" or "ringing" state during the assignment, a fixed assignment occurs. A "fixed" assignment of a line to an SPM channel remains in effect even after the connection is cleared.

If the line is in the "hold", "call" or "with remote seizure" state during the assignment, a fixed assignment occurs. The assignment of the line to an SPM channel is deleted at the end of the connection.

It is possible to switch between a fixed and temporary assignment at any time. The assignment of a line to an SPM channel is performed automatically or selectively.

Assign Line Automatically

The line is assigned to the next free SPM channel by pressing a key

The assignment is temporary.

Assign Line Selectively

In SPM Selection mode, the assignment of a line to an SPM channel is temporary.

Switching between a fixed and temporary assignment is only possible if an assignment on the SPM channel exists, and the assignment is not "fix-protected".

Switch between Speech Monitoring and Two-way Call

Switching between the "SPM" and "Call" states is always possible on an SPM line.

Change SPM Assignment (Fixed/Temporary)

The assignment of a line to an SPM channel is temporary.

A temporary assignment is deleted at the end of the connection.

A fixed assignment is retained after the end of the connection.

Delete SPM Assignment

A line that is deleted from all SPM channels of an OpenScape Xpert terminal retains its call-processing state (i.e., a line on hold remains on hold (and analogously for "idle", "call" and "seized")).

Save/Load SPM Assignments

A maximum of five different SPM assignments can be saved at the OpenScape Xpert terminal and loaded again later. The current SPM assignment is overwritten in the process.

Disconnect SPM Line

SPM Disconnect and Kill Line can be used to disconnect an SPM line on the selected handset.

The "Push to Talk" functionality (OpenScape Xpert terminal), which is available for all SPM channels, is designed for operation with a mouse or using keyboard shortcuts. When using a keyboard, it is also possible to use the "multi-finger technique".

Functions

- Save SPM assignment
- Load SPM assignment
- Assign line selectively to SPM (temporary)
- Assign line selectively to SPM (fixed)
- Assign line automatically to SPM (temporary)
- Assign line automatically to SPM (fixed)
- Assign line automatically to SPM (temporary)
- Change SPM assignment
- Set volume of channels and loudspeakers
- Mute channels and loudspeakers
- Delete SPM assignment (with SPM programming)
- Delete SPM assignment and disconnect (with SPM Disconnect)
- Enter speech-monitored line
- Return line to SPM

3.40 Central Voice Recording (IP)

The MLC provides the interface for voice recording over IP. The voice recording itself is handled by a system from an external vendor.

The following can be recorded.

- line
- Speech unit, e.g., handset
- SPM modules (4 speech monitoring channels)

The voice recording via the MLC (IP) and the assignment of the line, the handset speech unit and the speech monitoring loudspeaker to the output

Features of OpenScape Xpert Terminals

Multi-Streaming to Voice Recorders

channel are configured at the System Manager. The voice recording for current calls at the active speech unit can be enabled or disabled at the OpenScape Xpert terminal (optional).

Functions:

- Enable or disable voice recording for speech unit.
- Enable or disable voice recording for line.
- Enable or disable voice recording as always active from the start.
- Enable or disable voice recording during a call (optional).
- Export voice recording channels via the System Manager

Calls on a line are always recorded if they are configured for voice recording and are not switchable by the terminal user.

If voice recording has been activated on the line by the system administrator, but no voice recording channel has been assigned for it, the OpenScape Xpert terminal user receives a corresponding advisory message on conducting a call.

The currently released voice recorders and applications can be found in the Release Notice.

3.41 Multi-Streaming to Voice Recorders

The same stream can be recorded on two or more voice recorders to increase the security of the system. In the case of a failure of one voice recorder, there is always at least one redundant voice recorder.

Function Description

The voice recording stream is sent from the MLC. The voice recording itself occurs on the recorder. When an MLC is starting up, it receives all information on the data stream to be recorded from the System Manager. After the connection is established, the MLC starts streaming the voice data automatically to the recording devices. Some streams are controlled on the MLC on the OpenScape Xpert terminal. In this case, the OpenScape Xpert terminal sends a message to the MLC to start the recording for the speech unit. The MLC knows where to send the recorded stream. The MLC sends the streams to the voice recorders; the Master Tradeboard sends the actual call data.

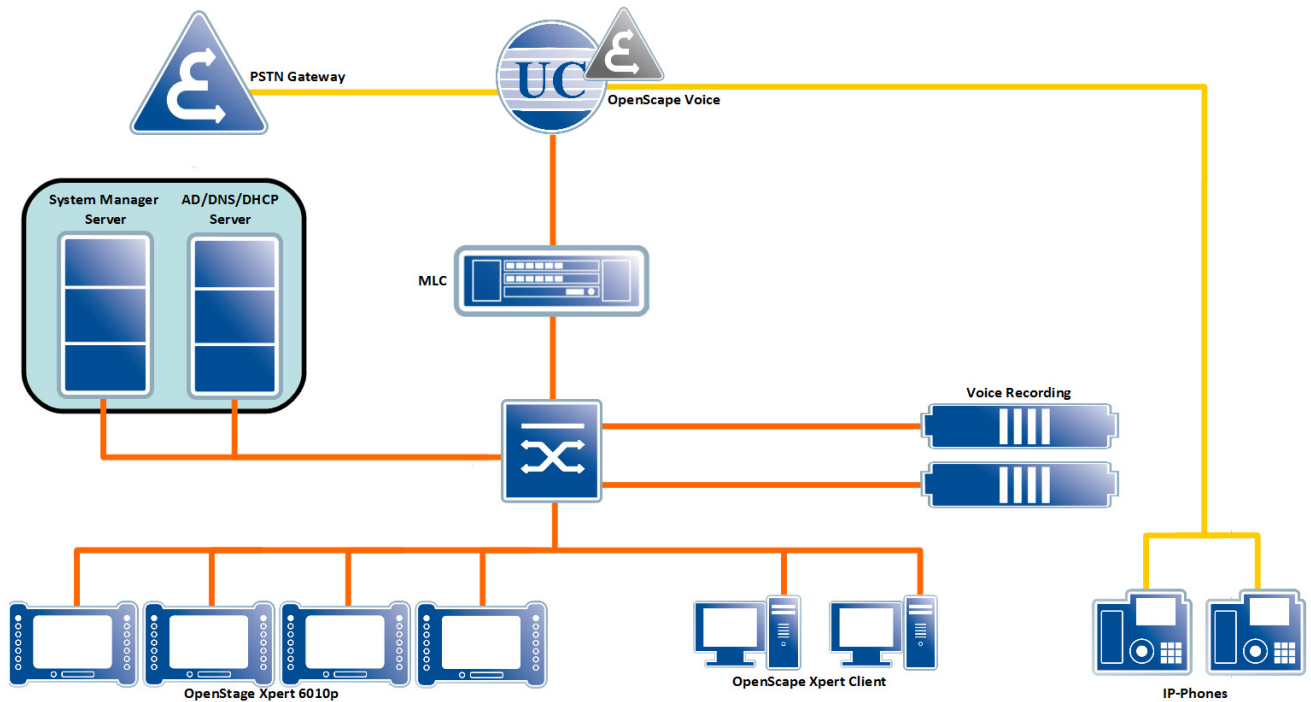

3.42 OpenScape Xpert Terminal Soft Client for Back and Middle Office

The OpenScape Xpert client application is a soft client solution and can thus also be set up in an existing customer environment, e.g., on an office or business PC at the workplace of the user. In general, other applications can be installed and run on the OpenScape Xpert terminal in addition to the OpenScape Xpert client.

However, since the resources of the client PC are limited (e.g., CPU load, memory usage, video resources, LAN bandwidth, etc.), this may affect performance. OpenScape Xpert has only been released with the tested applications. See the Release Notice for OpenScape Xpert for more details. The use of other applications at OpenScape Xpert terminals is not prohibited, but the performance, quality and availability of OpenScape Xpert could then possibly be affected.

IMPORTANT:

Do not install any third-party software on the OpenScape Xpert servers and client PCs without the approval of Product Management and do not connect any third-party components to the OpenScape Xpert interfaces. The currently approved third-party products can be found in the OpenScape Xpert project planning guide.

Features of OpenScape Xpert Terminals

Remote Access through a Firewall

3.43 Remote Access through a Firewall

The OpenScape Xpert application can be operated through firewalls via an unrestricted VPN tunnel.

3.44 Online Help

The online help contains assistance and additional reference topics on the use of OpenScape Xpert terminals.

Two types of help are available:

- the online help and
- the context-sensitive help, which provides details on the selected desktop element.

The language of the online help does not always match that of the user profile. If no online help is available in the language of the user profile, the English online help is displayed.

3.45 Screen Display and User Mode

The OpenScape Xpert user interface supports different screen displays and resolutions, as well as two different types of user modes (mouse-controlled or touch screen).

Screen Displays

- Full Screen Mode
- Windows Mode

The OpenScape client is displayed in full screen mode when the resolution selected at installation matches the resolution set for the operating system. Otherwise, the OpenScape client is displayed in Window mode.

Screen Resolution

The optimum resolution in "full screen mode" is 800x600 or 1024x768 pixels. If the user interface is displayed at higher screen resolutions, the quality of the display is significantly reduced by the interpolation of the graphics card.

When setting up the OpenScape Xpert software, you can choose between the following settings:

- SVGA with 800x600 pixels
- XGA with 1024x768 pixels

No settings are required at the System Manager.

User Mode

The OpenScape Xpert user interface is optimized for touch-sensitive screens (touchscreen). The interface can, however, also be operated using the computer mouse, e.g., at an OpenScape Xpert client PC without a touch-sensitive screen.

Touch Calibration under Linux

On the OpenStage Xpert 6010p and Mitel Xpert 6020p devices (Linux) the touch screen calibration function is available. This function allows the user to start the xinput-calibrator tool which improves the touch screen preciseness.

3.46 Keys on the OpenStage Xpert 6010p/Mitel Xpert 6020p Units

The OpenStage Xpert 6010p and Mitel Xpert 6020p have 20 hardware keys (hardkeys). The functions of these hardkeys are usually identical to those of the adjacent soft keys (button images on the graphical user interface).

Fixed Hardkey Layout

The administrator has the option of permanently assigning hardkeys to a specific page.

The administrator can select an existing page for the respective user. This can be any page that is already in the profile.

The user can change the hard key functionality by simply changing the buttons on the reference page. To provide easy feature handling, some of the options for the labeling of keys have been omitted or restricted.

3.47 2-in-1 Function

If the 2-in-1 function is set, two handsets (or a handset and a headset) are working in parallel. The 2-in-1 functionality can be activated at the System Manager side. So it is not changeable for the user (at the client side).

The call handling is as follows:

- Both handsets appear in the GUI as one handset (if possible it is configured both handsets as number one or two).
- An incoming call can be accepted from both handsets (cradle switch over).
- In case of both devices are connected or picked up, the conversation will only be ended, when the last handset is hung up (cradle switch over). Doesn't matter which handset picked up the call first.
- Both handsets can talk and listen to the line at the same time.
- "Push to Talk" and "Push to Mute" are supported at all handsets and must be enabled in the GUI from the active handset or, if both handsets are active, from the one that picked up the call first.

3.48 US Call Tones

Call tones for dialing, ring back or busy tones, for example, are different in many countries. People living in that country are familiar with those tones and could be confused by tones from other countries. From OpenScape Xpert V4R5 on, the call tone profile can be configured.

Function Description

Features of OpenScape Xpert Terminals

Date and Time Display

The OpenScape Xpert V4 used to play European call tones like dial, ring back or busy tones only. From OpenScape Xpert V4R5 on, the generation of call tones could be configured by the administrator. The MLC has been modified to send the necessary call states to the OpenScape Xpert client. To generate the correct call tones the new **Locale** setting has been introduced to the user profile. On the System Manager the administrator can configure this parameter for each telephone user. Possible settings are **Europe** or **United States [us]**.

The **Locale** parameter sets the tone profile and the date and time display format, e.g. U.S. tones and U.S. date and time format (mm/dd/yy, 12 hour time).

3.49 Date and Time Display

The current date and time are displayed in the status bar of the OpenScape Xpert user interface.

Example: United States [us]:

For each user profile, the "Locale" parameter can be configured at the System Manager. This parameter sets the tone profile and the date and time display format, e.g. U.S. tones and U.S. date and time format (mm/dd/yy, 12 hour time).

04/06/14 2:44PM

NOTICE:

If the "Locale" setting for the current profile is set to "United States [us]", the date and time in the call memory journal will be displayed in the US format as well.

3.50 Automatic Echo Cancellation

Automatic Echo Cancellation (AEC) improves the voice quality at the OpenScape Xpert terminal.

Function Description

Automatic echo cancellation can be enabled on the OpenStage 6010p, Mitel Xpert 6020p or the client PC for certain audio accessories (such as Xpert gooseneck microphones or handsets). To this end, the service technician changes one parameter per USB port in the ini file of the corresponding terminal.

3.51 Speaker Module (Add-on Device)

Up to two speaker modules can be connected to the OpenScape Xpert terminal. An additional microphone per client can also be connected to one of the speaker modules.

Overview

The OpenStage Xpert speaker module provides outstanding voice quality and allows the user to easily distinguish between several conversation channels put on a loudspeaker. The speaker module is controlled by the connected OpenStage Xpert terminal. All functions available for the main device and applicable on the speaker module work the same way on the speaker module.



Features

The main features are as follows:

- The speaker module can be used to monitor up to two speech monitoring modules (SPMA/SPMB or SPMC/SPMD) with up to four mixed speech monitoring channels each.
- It is possible to monitor up to eight SPM channels simultaneously.
- The speaker module comes with an own graphical display showing channel information provided by the connected OpenStage Xpert Client.
- Each SPM channel has its own volume controller.
- There is also an additional volume controller for each speaker. Which SPM modules are regulated by these volume controls depends on the respective usage mode.
- Each of the eight SPM channels is assigned a pushbutton. In addition, there is also a group button for each SPM module.
- There are five pushbuttons which can be flexibly assigned for various operation modes. The buttons are designed as toggle/shift buttons and have a special functionality in combination with the pushbuttons assigned to the channels.
- The speaker module allows to communicate in hands free mode.
- One gooseneck microphone (Goosie07, Goosie09) can be connected to be used e.g. for announcements.
- An acoustic echo cancellation in hands free mode and acoustic echo suppression in announcement mode assure high voice quality.

Usage Modes

Depending on the setup, there are various usage modes, which are described in this section. SPM modules configured on a speaker module appear on the OpenScape Xpert client's user interface, but are grayed out (disabled), and the corresponding buttons are inoperable – if set in the user profile.

- **Simple SPM Mode**

In this mode, up to two SPM modules are configured on the speaker module.

- **SPM Mode and Input Device (Gooseneck Microphone) Connected**

In this mode, up to two SPM modules and one gooseneck microphone are configured on the speaker module.

The output of the SPM modules occurs as in the simple SPM mode on the respective speakers in the speaker module. In addition, the gooseneck microphone is configured at the speaker module instead of the OSX client. The output for the gooseneck microphone still occurs via the hands-free speaker at the OSX client. Improved acoustic echo cancellation occurs for announcements, but not in the hands-free mode.

- **Hands-free Mode**

In this mode, the speaker module is divided into two different sections. The connected microphone and one speaker are configured as speech unit. The remaining speaker is configured for SPM modules. The SPM speaker can be used for the output of one or two SPM modules.

The microphone can be used for calls on the speech unit (hands-free) as well as for announcements on the SPM units. The voice quality of the microphone is highest for announcements and during hands-free usage, since the echo cancellation implemented in the hardware is used for both functions.

In hands-free mode there is only one main volume control for all SPM channels, since all SPM channels are output on one speaker.

- **Audio Streaming Mode**

This mode is, for the most part, similar to the hands-free mode.

One speaker is used for up to 2 SPM modules, but the other, in contrast to the hands-free mode, is not used for an optional gooseneck microphone, but as the PC speaker, e.g., for the acoustic playback of video streams in the web window of the OSX client. The echo cancellation for hands-free calling is then not available.

Scenarios with Two Speaker Modules

If two speaker modules are connected to the OpenStage Client device, the following cases may arise:

- Both speaker modules are in SPM mode:

The two speaker modules behave as described in the section "Simple SPM Mode", i.e., independently of one another.

- One speaker module in SPM mode, one speaker module in SPM mode plus input device:

The SPM mode speaker module behaves as described in the "Simple SPM Mode" section; the other speaker module as described in the "SPM Mode and Input Device" section.

- One speaker module in SPM mode, one speaker module in hands-free or audio-streaming mode:
This behaves like described in the respective sections above. Open listening for the connected handsfree or streaming unit is not allowed and disabled by the OpenStage Client device.
- One speaker module in hands-free mode, one speaker module in streaming mode:
This behaves like described in the respective sections above.

3.52 How to Call during an Announcement (Hoot-n-Holler Function)

During an active announcement, an incoming call can be answered on a separate speech unit, added to the announcement or disconnected.

Function Description

The Hoot-n-Holler function enables users to accept incoming calls on one of their own speech units, add them to an announcement or disconnect such calls during an active announcement (variable announcement, fixed group announcement or SPM announcement)

Prerequisites:

- An appropriate speech unit, e.g., a gooseneck microphone for announcements, has been permanently assigned via the System Manager.
- The "Comfort Activation" function has been enabled for incoming calls.

3.53 Feedback tones during dialing

The System Manager or the OpenScape Xpert terminal can be used to configure feedback tones during dialing.

Function Description

When you use the dialpad of the OpenScape Xpert terminal for dialing, you will hear one of several feedback tones. This feature must first be enabled at the System Manager or at the terminal.

3.54 Re-ring Signal

The "Re-ring Signal (Manual Ringdown)" function is used to initiate a re-ring signal at the remote user on a dedicated line.

Function Description

Usually, the "Re-ring Signal" feature is used on dedicated lines. Subscribers can send each other re-ring signals, which are signaled audio-visually on the terminal. On receiving an incoming re-ring signal:

- the symbol for call signaling appears for about 2 seconds on the line key
- a short beep will sound for about 1 second: a period of the set ring tone.

3.55 Suffix Dialing for DKM Keys

DKM keys can be programmed for suffix dialing so that individual extensions can be dialed manually, for example.

Function Description

For DKM keys with suffix dialing, the digits up to the "suffix dialing" control character are processed as if they had been entered one by one. The system then waits for further input from the user who can enter digits as part of a normal dial string and make corrections as necessary. If the entered suffix digit sequence is not confirmed by pressing the Enter key, the system dials automatically after the configured time.

- "W" is the suffix dialing control character.
- The suffix dialing control character must be preceded by a digit sequence.

The control character "W" is only possible for DKM keys.

3.56 Control Characters for Dialing Delay

The dialing delay option can be used to enter an inter-digit pause.

Function Description

When programming DKA, DKM and the Contacts, the Pause control characters p, P and F can also be programmed in addition to the input of characters (0 through 9, * and #):

- p stands for a dialing delay of half a second,
- P for a dialing delay of one second,
- F stands for a dialing delay of 5 seconds.

The control characters p, P and F may be entered more than once.

3.57 Confirmation Prompt before Exiting the OpenScape Xpert Client Software

To prevent accidental closure of the OpenScape Xpert client software, the user receives a confirmation prompt upon exiting the application.

Function Description

The OpenScape Xpert client software is displayed in a window on the Windows client PC. If users accidentally click on the "Close" icon, the application will not be closed immediately but a confirmation prompt appears. This prevents users from accidentally exiting the application and allows them to continue with any ongoing calls even if they accidentally click the "Close" icon.

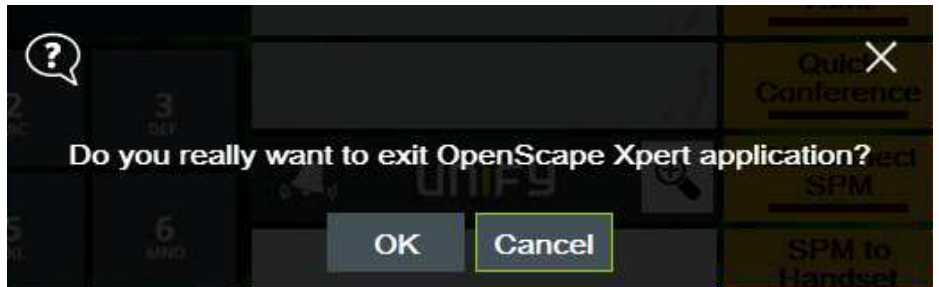

3.58 Ring Tone Disabled Display on Line Keys

The ring tone can be disabled for individual lines. This is shown on the line key itself.

Function Description

The ring tone of a line key can be turned off via the context menu of the line key. A turned off ring tone is shown on the line key with a crossed-out bell icon.

3.59 Displaying the Number of the Assigned Speech Unit

The number of an assigned speech unit appears on the line key.

Function Description

The System Manager can be used to permanently assign a speech unit to a line key. The number of such a speech unit is shown on the line key itself to prevent the user from accidentally disconnecting a call for this speech or from placing it on hold.

3.60 Volume Normalization for SPM Channels

The volume of the SPM channels can be normalized to a specific level.

Function Description

Volume normalization can be enabled or disabled separately for each SPM channel at the OpenScape Xpert terminal. The automation makes it possible to set a target volume, regardless of how loud the incoming SPM channels are. This eliminates any need for subsequent volume readjustments for sources with different volume levels.

Under SPM properties, there is a "Normalize" checkbox which can be enabled per SPM channel (1...4). Once enabled, this function takes effect immediately.

Features of OpenScape Xpert Terminals

Location identification for emergency calls (E911 support)

3.61 Location identification for emergency calls (E911 support)

In some U.S. states, there is a legal requirement to transmit the location information for emergency calls to the rescue coordination center.

Function Description

The unique MAC address of the terminals is used for unique mapping of location information and OpenScape Xpert client. A unique MAC address is stored in the database for each terminal. At the System Manager, this MAC address for location information is shown under "Software Version".

When a phone call is made from a OpenScape Xpert client, the MAC address is transmitted to the MLC. The MLC attaches the corresponding domain suffix to the SIP INVITE message so that the terminal can now be located.

To simplify administration, all unique MAC addresses of the connected Xpert clients can be exported to a file.

3.62 "SPM-to-handset" function key

The "SPM-to-handset" function key can be used to place a speech monitoring channel on a handset.

Function Description

Switching an SPM channel from "announcement" to normal call on a handset requires fewer steps if the user uses "SPM-to-handset" function.

After pressing the "SPM-to-handset" function key, the user selects the desired SPM channel. The call is then automatically placed on a speech unit determined by the OpenScape Xpert client:

The speech unit is selected according to its priority. The priority is determined as follows:

- If configured, the default speech unit of the line has the highest priority.
- The default speech unit of the user has the second highest priority.
- The other priorities are determined by the identification number of the other speech units. Speech unit 1 has a higher priority than speech unit 2, etc.

The function key in idle state:



The active function key:



3.63 Visual announcement indicator on SPM channels

On shared lines and SPM channels, announcements from other OpenScape Xpert clients are shown with a people icon to prevent simultaneous entries into lines.

Function Description

A call on a line was set to speech monitoring by several OpenScape Xpert terminals. Once a user makes an announcement on this line, it is displayed to the other users on the appropriate line key, as well as the SPM-channel key with a yellow or red icon people. The following events are shown on the Keys:

- Line key on which another user is currently making an announcement.
- SPM channel key on which another user is currently making an announcement.
- Line key on which your own announcement and another user's announcement are currently active.
- SPM channel key on which your own announcement and another user's announcement are currently active.

3.64 OpenScape Voice UC Basic Integration

OpenScape Voice UC (Unified Communications) is an excellent and scalable communications solution based on an open and virtualized software architecture.

Basic Integration of OpenScape Xpert in OpenScape Voice UC

Using the current UC solution (third-party CTI) coupled with the OpenScape Voice system, it is possible to make a call in the same way as with the OpenStage telephones (SIP).

3.65 Extension to 24 Speech Monitoring Channels

Every 4 speech monitoring channels are combined into one SPM module, represented by "A", for example.

Overview

Up to and including OpenScape Xpert V4R5, it was possible to have up to 16 SPM channels a terminal: SPM modules A ... D. As of Version V4R6, up to 24 SPM channels are supported, i.e., the modules E and F have been added. The functionality and operation of the SPM channels have not changed.

The following figure shows the user interface:

Features of OpenScape Xpert Terminals

Screensaver Settings on OpenStage Xpert 6010p/Mitel Xpert 6020p



3.66 Screensaver Settings on OpenStage Xpert 6010p/Mitel Xpert 6020p

The user can configure the screensaver settings on the client device .

The following settings are available:

- When to turn down the backlight or turn off the display.
- Whether the screen saver settings should be applied during calls.
- The backlight luminance value when the screen saver is off.
- The backlight luminance value when the screen saver is on.

3.67 Improved Menu Dialog System

The dialog system has been improved offering easy navigation.

From OpenScape V5R1 on the dialog system uses a breadcrumb system to provide easy navigation in the dialog hierachy.

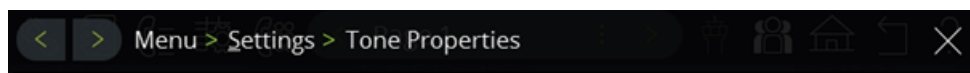

The leftmost element represents the main dialog, the second element is the subdialog opened from the first one, and so on. The last element represents the dialog currently active.

The breadcrumb shows a trail from the starting point to the current dialog.

Clicking one of the breadcrumb elements closes all subdialogs opened from it (i.e. the breadcrumb elements from its right) and shows the subdialog of this element. If the text is too long, it can be scrolled with the scroll buttons.

3.68 OpenScape Xpert Client Usability Improvements and Maintenance Mode

The usability of the client's graphical user interface has been improved. This section shows some of the improvements.

The following improvements are provided form OpenScape Xpert V5R1 on:

- Edit mode (Dark Style)



- Edit mode (Light Style)



The former right-mouse-button on the touch screen and it's context menu functionality have been replaced by a modern usability concept. The user clicks the new "Edit Mode" button in the menu bar. The user interface changes to the maintenance mode and offers all relevant functionalities.

- New toolbar icons in maintenance mode



The new toolbar icons or elements in maintenance mode are (from left to right):

- Exit maintenance mode button
- Undo button
- Redo button
- Copy/Move button
- Undo selection button
- Page selection widget
- Load and save SPM assignment button
- Quick conference button
- Home page button
- Previous page button
- Context sensitive help button
- Load and save SPM assignment

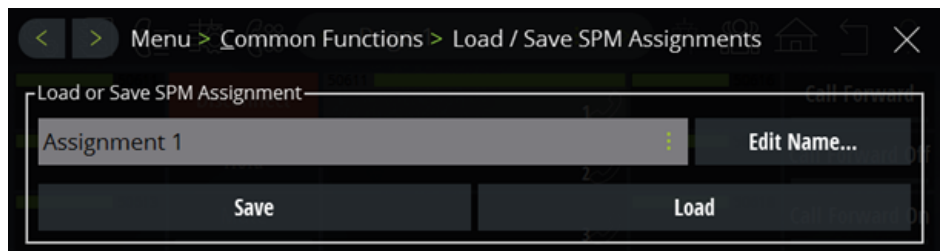

The user can save the current SPM assignment state or load another SPM assignment.

Features of OpenScape Xpert Terminals

- Changing SPM assignment indication on SPM lines

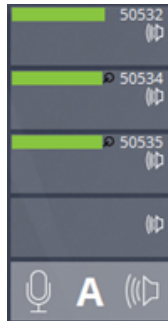

The "unpinned" symbol on the SPM line in case of temporary assignment has been abolished. If a line is fixed on SPM, the SPM line shows it with a little symbol on the most left side of the line label part. If a line is only temporarily assigned to SPM the SPM line will not show that little symbol. In the example figure above the second and third assignment is fixed.

- Improved SPM Panel and Voice indication on SPM lines



Every line assigned to a channel on an SPM panel has 3 icons (from left to right):

- Select icon: selects the assignment on the channel.
- Pin icon: identifies and enables to change the assignment type (see Changing SPM assignment indication on SPM lines).
- Remove icon: removes the assignment from the channel of the SPM panel.

The voice indication on SPM lines is changed to be the same as on the Speaker Module user interface. For this purpose a newly designed voice indication field is introduced in the fourth row.

On the 5th row of the SPM panel is the SPM Properties (gear) icon and SPM Panel Mute (speaker) icon. The SPM Panel Mute icon mutes the whole SPM panel regardless of the settings of the channels on the panel. The SPM Properties icon opens the dialog for the SPM panel (see below).

- SPM Properties



On the SPM Properties dialog the user can select an SPM panel via the unit selection widget. The following options are available for the selected SPM panel:

- Volume adjustment for each channel
- Mute each channel one-by-one
- Normalize the volume for each channel
- If a channel has an assigned line, change the type of assignment between fixed and temporary
- If a channel has an assigned line, delete the assignment (only if not fixed).
- Change the volume or mute the speaker

3.69 Call Forward ON and OFF Function Keys

New function keys “Call forward ON” and “Call forward OFF” have been introduced from OpenScape Xpert V5R1 on.

The new function keys – Call forward ON and Call forward OFF - are introduced to complement the Call Forward function key which toggles the call forwarding state of the line.

These new function keys do not appear in the speech unit context menu or any other place. Only the current speech unit is affected and this feature is accessible from these function keys only.

- Call forwarding works for busy line, if it is seized manually on a speech unit.
- Call forwarding does not work for unavailable lines, as the line cannot be selected (it's disabled).
- The new function keys will be used primarily in macros, but it is possible to put them on regular profiles as well.

3.70 Cleaning

For Linux-based clients there is a function key which makes it easier to clean the device by disabling the input peripherals.

When the Cleaning function key is pressed, the hard keys and touch screen are disabled for 30 seconds. During this time, the incoming calls can be answered by picking up the handset.

3.71 Configurable statusbar text

In the System Manager - OSX Client settings, it is possible to set a custom text to be displayed on the center of the client's toolbar.

3.72 Shared Audio with Soft Client

Audio device usage can be exclusive or shared on Windows-based soft clients. Shared mode allows other applications to use the same device used by the client.

3.73 Configurable font size

In the **System Manager - Profile settings\Basic\General**, it is possible to switch between the **Default** and **Tight** font size on the client GUI.

- Default - The font size of every text is set to default.
- Tight - The font size of the text on DKAs, DKMs, CallQueue elements, Speech Units and Lines increases if the available space allows it.

4 Features of Lines

This section describes the features of lines.

4.1 Line Seizure

In OpenScape Xpert, lines are seized in different ways.

Automatic seizure of a line

When a line is seized automatically, an attempt is first made to seize the precedence line, and if this line is busy, the system automatically searches for a free line.

See also "Line group overflow".

The automatic seizure of a line occurs:

- on dialing with the dial pad
- on pressing a DKA (direct key automatic)
- on pressing a DKM (direct key manual)
- on dialing from the Contacts
- on dialing from the call memory (call journal)
- for LNR (Last Number Redial)
- for SNR (Saved Number Redial; incoming connection)
- for SNR (Saved Number Redial; outgoing connection)

Specific seizure of a line

If a specific line is to be seized, a line key must be pressed before dialing with the dial pad or a DKM. In addition, a prefix can be saved for the line keys.

The internal selection mechanism (fixed order or random selection) of the next free line within a line group can now be selected freely.

Comfort activation (settable per line)

The comfort activation (only possibly for handsets with cradles) of the calling line at the handset of the OpenScape Xpert terminal can be set per line at the System Manager server as well as the OpenScape Xpert user interface and is thus no longer dependent on the "Ringer/Ring Tone" setting.

The comfort activation of the handset always refers to the topmost (call) entry in the call queue.

Possible settings:

- The calling line is answered on lifting the handset
- The calling line is not answered on lifting the handset

Line Group Overflow

Line groups are configured for an OpenScape Xpert system and can be cascaded in multiple levels. The cascading of line groups at the System

Manager server and for the terminal also provides the functionality of a line group overflow for outgoing calls.

The cascading of line groups and the corresponding settings define the sequence in which lines are seized in and across the line groups for all profiles of an OpenScape Xpert system.

Line seizure sequence:

Different settings are possible here.

For example: first select own lines of the same line group, followed by lines of the upper line group, and so on, until the root of the line groups and the lines configured there.

The behavior of lines in a line group (e.g., group B) can be defined at the SM:

- **Overflow to Upper Group:** If no further line is free in the group, and this parameter is activated, an attempt is made to find a free line in the next upper group. This is not activated by default.
- **Use Neighbor Line within Same Group:** An attempt is made to find a free line in the own group. This is activated by default.
- **Seize Random Line instead of Preselected Line:** The system does not use the default line assigned to the OpenScape Xpert terminal, but another line of the same line group. This line is selected at random.

Toggle

The "Toggle" function is used to switch between multiple calls. It enables calls to be accepted at the same handset without disconnecting the first call. The first connection is placed on hold. The waiting user cannot listen in on the new call.

There are two options:

- Automatic toggle (without a Toggle key),
- PBX - Toggle with Toggle key

Transfer

There are two transfer options for calls:

- Blind transfer (Tepid transfer)
- Transfer with Consultation Call:
 - Warm: the consultation call is answered
 - Tepid: the consultation call is not answered yet

Automatic toggle

The user is conducting a call and wants to speak alternately with other subscribers on the same handset without ending the ongoing calls. The prerequisite for this is that the other subscribers are in the "ringing", "remote seizure" or "hold" states.

When a consultation hold has been initiated, the user can switch between the last two calls only with the "Toggle" function.

Toggle functions are possible:

- with a Line Key

- with DKA
- with Call Concentrator
- with SPM channel key
- from the Contacts
- from the call memory
- with LNR

Automatic Answer

With Automatic Answer (AA), calls can be answered automatically (without checking the A-number) without the need for any action on the part of the user. The line to be answered automatically can be on an SPM loudspeaker, but is not automatically placed on a speakerphone or open listening loudspeaker or handset.

It can be used as a normal line for outgoing connections and can be released normally (entry at OpenScape Xpert terminal and Disconnect) or with Kill Line.

For each line, the System Manager can be used to configure whether it should be placed in the "hold" state or released when one of the "normal" release options (Disconnect, GU, Release key,...) is used for the last active OpenScape Xpert terminal on that line. A line can always be released with the Kill Line key.

Typical use cases:

Hoot&Holler lines are answered automatically so that remote users can make a direct announcement.

Note

If a line is set to "Automatic Answer", a call on that line will always be answered, regardless of whether or not an OpenScape Xpert terminal is logged in.

If a line is set to "Hold when Released", the line is not released when the last OpenScape Xpert terminal logs out.

4.2 Privacy per Line

The "Privacy" function can be used to protect a call against an entry or disconnect by another subscriber (i.e., to prevent silent monitoring).

The automatic disabling of a line shared across multiple OpenScape Xpert terminals (privacy) and from all speech monitoring loudspeakers as soon as a subscriber enters that line can be configured per line.

The "Privacy" protection always applies only to the current call.

Lines can be protected with "Privacy".

Functions

- Signaling on the Privacy key
- Enable or disable privacy auf on a shared line
- Privacy activated remotely
- Entry into privacy-protected line
- Enable privacy when line is entered by external party

Features of Lines

Voice Recording Switchable at the OpenScape Xpert Terminal (per Line)

- Privacy from beginning
- Privacy on hold

4.3 Voice Recording Switchable at the OpenScape Xpert Terminal (per Line)

The voice recording for current calls can be enabled or disabled at the OpenScape Xpert terminal.

The following settings can be made by the system administrator for each line:

- Enable/disable voice recording from the beginning
- Enable/disable voice recording switchable by the user

The OpenScape Xpert terminal user can turn voice recording on or off during a call by using the "Voice Recording" function key, provided this has been released by the system administrator.

The activated voice recording is shown to the OpenScape Xpert user in the call control field individually for each speech unit (on/off).

If an OpenScape Xpert user turns on voice recording on a line for which no voice recording channel has been configured by the system administrator, the user receives an alert tone and a corresponding message in the status line.

4.4 Voice Recording per Line

The MLC provides the interface for voice recording over IP. The voice recording itself is handled by a system from an external vendor. The following can be recorded:

The following can be recorded:

- Lines
- Speech units, e.g., handset
- SPM loudspeaker (sum of 4 monitoring channels)

The voice recording via the MLC (IP) and the assignment of the line, the handset speech unit and the speech monitoring loudspeaker to the output channel are configured at the System Manager.

If voice recording has been turned on by the system administrator for the line itself (line recording), it cannot be turned off by the OpenScape Xpert terminal user.

4.5 "Different Dial Prefix" FK

The "Shift" function for outgoing dialing operations on line keys enabled an alternative line prefix to be dialed for lines.

Alternative Outbound Number FK

If the function is activated (key is pressed), the status field of the FK blinks with low frequency. The blinking remains in effect as long as the function is being used (i.e., until the end of the function or manual deactivation by the user).

A further example: when the FK is not enabled, the number of the activated line is transmitted. When the FK is activated, the alternative line prefix applies, and the number is suppressed. The line prefix can only be programmed at the System Manager.

4.6 "Hold Concentrator" Function Key

Lines placed on hold are shown in the call queue on the own OpenScape Xpert terminal. If the line has also been programmed with a "common hold", the held line is displayed in the call queues of other OpenScape Xpert terminals as well.

Please note that on pages with 60 keys per page, the call queue will be in the background and must be brought to the foreground with the "Control Field" menu key (Switch on/off control field).

Lines on hold are, however, also shown on the "Hold Concentrator" keys if these function keys have been programmed. On pressing the "Hold" key, the first held line is parked on the FK "Hold Concentrator 1". A second call placed on hold is parked on the FK "Hold Concentrator 2", and so on.

This functionality applies to the following hold states: "Common Hold" at the own OpenScape Xpert terminal, "Private Hold" at the own terminal, and "Common Hold" of a subscriber whose line is programmed with "Common Hold in Call Queue".

Example: The first line is in the "Common Hold" status and shown on the "Hold Concentrator 1" key.

The line is only shown in the call queue or the "Hold Concentrator x" FK if the parameter "Call Queue Entry/Concentrator Active" has been set. This can be activated or deactivated at the System Manager, the client or (if "changeable" is set to yes) even at the OpenScape Xpert terminal.

The max. 10 "Hold Concentrator x" function keys can only be programmed per profile at the System Manager.

The call can, of course, still be entered in the call queue (if present) or placed on hold as usual.

4.7 Automatic Recall for Calls on Hold

The "Automatic Recall for Lines on Hold" functionality is enabled at the System Manager on a system-wide basis (and applies to all profiles). It initiates a recall after a timeout for one or more lines on hold.

The settable timeout can be from 0 to 1200 seconds (20 minutes), where 0 results in no recall. The recall tone is fixed and cannot be changed. The recall is always activated at the profile that first placed the line on hold.

4.8 Incoming Call Concentrator

An incoming line is shown at the topmost position in the call queue. On pages with 60 keys per page, the call queue will be in the background and must be brought to the foreground with the "Control Field" menu key (Switch on/off control field).

Up to 10 function keys (Incoming Call Concentrator 1 to Incoming Call Concentrator 10) are possible per profile. The first call can thus be answered by pressing the "Incoming Call Concentrator 1". A second call by pressing "Incoming Concentrator 2", and so on.

Example: Two lines are in the ringing state. The first call is signaled on the first "Incoming Concentrator 1" key. The second call is signaled on the "Incoming Concentrator 2" key". The "Incoming Concentrator 3" key is free.

The max. 10 "Incoming Call Concentrator x" function keys can only be programmed per profile at the System Manager. The call can, of course, still be entered in the call queue (if present) or answered as usual.

4.9 Quick Conference

The Quick Conference provides the possibility to extend a conference without putting it to hold before. The new line is selected automatically.

Options for Initiating a Quick Conference

Depending on how long the function key or button is pressed on the toolbar, the system switches to the **Quick Conference One-Action** or **Quick Conference Permanent** editing mode.

One-action editing mode: In this mode you can set up a three-way conference or extend an existing conference with a new party.

Permanent editing mode: In this mode you can set up a conference with two or more users or extend an existing conference with multiple parties.

NOTICE:

If Quick Conference is started by a Macro, then the **Permanent** editing mode is used.

Beep Tone when Adding a Line to a Conference

Two different tones can be played to the users while in conference.

On creating or extending a conference, a beep tone can be played for all members. The tone is played after new lines are added and can be heard by all existing and new conference members. The tone is played when a line was added with the Quick Conference function. When multiple lines are added to the conference simultaneously, only 1 beep tone is played.

When attempting to add a new line to a conference connection that has not yet been established (because of a busy line, wrong number, etc.), a failure tone is played only for the user who tried to add the line to the conference.

The tones are played for quick conferences. Both conference tones can be enabled or disabled via the System Manager Admin in the user profile settings and will be played only if the user who wants to extend the conference has enabled the corresponding setting.

Conference with Privacy

It is possible to add private lines to the conference in the Quick Conference mode. This is naturally only possible if the added line is a private line for the current user.

If a private line is added to the conference, the privacy will not be disabled on the line. Other users who connect to the private line will not be able to hear the communication. However, if there is any non-private line in the conference, and another user connects to that line, the user can hear the entire conference. This applies to all conversations on both private and non-private lines.

When adding or removing a line to or from a conference, the privacy state of the lines does not change. Consequently, on adding a non-private line to a private conference, the conference will no longer be secure.

Conference with Intercom

If a conference was initiated via an intercom device (i.e., any device with a microphone, with or without a loudspeaker), the function key Disconnect or the on-hook action will cause the conference to completely disconnect; in other words, the conference will basically behave in the same way as in the Quick Conference mode, even if the Quick Conference mode is not disabled.

4.10 Own Line in the Call Memory

With OpenScope Xpert, there are several ways to determine which calls are stored in the call memory.

Mode of Operation

For shared lines, the user at the terminal or the administrator at the System Manager can set which incoming calls are to be displayed in the call queue and whether these are to be forwarded if necessary. The System Manager can also be used to define which calls are to be stored in the call memory.

Using the System Manager, the administrator can set for the following calls whether all, none or only the user's "own" calls are to be stored in the call memory:

Features of Lines

Multi-Line Appearance (MLA) with OpenScape Voice

- Incoming answered calls
- Incoming unanswered calls
- Outgoing calls

If "No calls" is set, no calls of the category are stored in the call memory. With the "All" setting, all corresponding calls are stored. When "Own" is set, the settings that were made for the call queue are checked, and only the own calls are then stored in the call memory accordingly.

4.11 Multi-Line Appearance (MLA) with OpenScape Voice

This section describes the feature "Multi-Line Appearance (MLA) with OpenScape Voice" for the connection of back-office phones to OpenScape Xpert systems.

Mode of Operation

The MLA feature of the OpenScape Voice systems enables multiple lines to be assigned to one terminal and a multiple line to appear at multiple terminals. Such device profiles are called a "keyset".

At the OpenStage SIP phones (OpenStage 60 and OpenStage 80), keyset lines (multiple lines) are each represented by one LED and a button. Consequently, calls that were set up at an OpenScape Xpert terminal can be connected to, held, received or interconnected with/by other members in the group (e.g., a SIP phone in a back office).

The MLA feature enables:

- Sharing of lines between OpenScape Xpert and OpenStage SIP phones
- Detection of lines in the "idle", "ring", "talk" or "hold" states
- Use of shared lines as normal lines to make or answer calls on both sides.
- Joining an existing call in progress (from devices of the type OpenStage 60 and above).
- The "Privacy" feature is not possible for MLA lines.

4.12 Preferred Identity Number

A pool of lines is used for external calls by several users. The identification of an external call (calling party number) can be selected by the user.

The system administrator can set the property "Preferred Identity Number" in the communication system for Xpert lines together with a calling party number. Using lines of this type enables you to create a speed dial contact (DKA) where a preferred identity number is displayed as the outgoing number of the calling party. This number can be a group number, a user's personal/private number, an intercom number or just the general number of the user's company.

Page Properties	Feature Properties
Edit Settings	
Pinned	<input type="checkbox"/>
Changeable	<input checked="" type="checkbox"/>
Call Signalization	
Call Queue Entry / Concentrator Active	<input checked="" type="checkbox"/>
Ringing Active	<input checked="" type="checkbox"/>
Cradle Active	<input checked="" type="checkbox"/>
Ringing Type	Ringing 1 ▼
Common Hold in Call Queue/Concentrator	<input type="checkbox"/>
Call Queue Priority	Low ▼
Prefixes	
Use Prefix	Local Line Prefix ▼
Default Prefix	<input type="text"/>
Alternate Prefix	<input type="text"/>
Call Behavior	
Suppress Call Forward	<input type="checkbox"/>
Preferred Identity Number	<input type="text"/>
Intercom	<input type="checkbox"/>

4.13 Two Lines on the Same Button

The same line (DN) of the OSV is registered by two MLCs via the MLA (Multiple Line Appearances) feature and is presented on the turret GUI behind one Line Key. Regarding configuration, there is a Primary and a Secondary MLC assigned to the Line in the System Manager. Based on this information, the turret Call Processing should ignore the line state notifications from the Secondary MLC as long as the Primary MLC for the line is available.

Limitations

- There is no hot-standby for call but the same line can be used after the 30 seconds outage.
- Due to the time limits in the OSV, the turret may be able to recover an active call if the far end is still there after 30 seconds and is heard nothing during this time period. In this case, the user is not able to hang up the call and use the line for another call until the OSV detects the Primary MLC's failure via SIP Session Timer. Depending on the configuration at the session timer, it takes at least 2 minutes. Until that time, OSV believes that Primary MLC has an active call on the Line.

4.14 Mass Call Forward List

The Mass Call Forward configuration contains a group of lines and their configured call forward destinations. If the MCF is added to a profile and the ON switch is pressed, then the lines configured for that MCF switch on their configured call forward destination. If the MCF key OFF switch is pressed, then the lines have their call forward cleared. Only the lines that are present on the profile will have their call forward setting changed.

Call Forward Destination

The call forward destination to be set for the specified line.

List View

The Mass Call Forward List shows all Mass Call Forward keys.

The following information is provided for each entry:

- Name

4.15 Transit

The function "Transit" allows lines to be connected together into a transit connection. Each user that has the function key "Transit" can create or expand a transit connection, but only the creator can release it.

The main point is that the creator automatically leaves Transit connection after finished with editing it.

The following functions are available:

- Create or expand Transit
- Enter existing Transit
- Disconnect Transit participant
- Release Transit by creator
- Hold Transit
- Release Transit by administrator (using Kill line function)

You can use the Transit function key in Trading Desktop or Phone Desktop to create and process Transit.

You can use the Select function key in the Trading Desktop or Phone Desktop to select a member of the Transit and remove them from the Transit. The participant remains on the active handset.

5 Features of a User Group

This section describes the features of a user group.

5.1 Free Seating

The user can log in at any OpenScape Xpert terminal with his or her profile name and password. The personal user profile is then loaded and logged in.

The user profile is maintained in the working memory of the OpenScape Xpert terminals. This means that the user can log in and out at the same terminal as often as required whenever the LAN connection to just the System Manager (database) is no longer available. On restarting the application or client PC, the profile is loaded from the System Manager at login.

5.2 Intercom

The "Intercom" feature provides a two-way intercom system between two subscribers.

Three functions are implemented with the Intercom:

- Speaker call, outgoing
- Speaker call, incoming
- Prevention of voice calling

Speaker call, outgoing

The speaker call connection is set up like a normal call, and the line used does not have to be configured for speaker calling.

Speaker call, incoming

A line with a speaker call can be entered automatically on receiving a ring or message if the following conditions are satisfied:

- The line is configured for the Intercom feature
- The speech unit assigned to the line is not in use

An incoming ring is signaled in the call field and on the corresponding DKA.

If no DKA has been configured, the directly called user, i.e., the user who receives the speaker call, sees the A-station or text (number or name) returned by the PBX in the call field.

If the configured speech unit is busy, the line is not entered automatically, but the call is placed in the call queue instead and signaled on the line and DKA keys.

If a directly called user (group member) receives a speaker call on a shared line with a single alert tone (300ms), but cannot enter that line, the remaining group members will still receive the direct call. For users who cannot enter the line, the line is signaled as "remotely seized".

Features of a User Group

If the playback of a periodic tone (which is generated locally at the OpenScape Xpert terminal at intervals of 15s and with a pulse of 300ms) is desired during a speaker call with an open handset or handset microphone, this can be set at the System Manager per user profile.

Intercom and Privacy

When a call is made to an intercom group, multiple OpenScape Xpert terminals enter the line simultaneously. If one of the group members has enabled the "Privacy from Beginning" setting, the rest of the group will no longer hear anything.

When setting up the intercom configuration, a warning window appears at the System Manager with a prompt (Yes/No) to verify whether "Privacy from Beginning" is to be turned off for this line. The OpenScape Xpert terminal user still has the option of setting "Privacy" manually.

The Privacy behavior can be changed at the System Manager at any time.

The setting is used whenever the OpenScape Xpert terminal enters a ringing intercom line (regardless of whether this occurs automatically or manually).

Prevention of Voice Calling (Speaker Calls)

When the "prevention of voice calling" feature is enabled, this setting applies to the entire OpenScape Xpert terminal. The ring from the source of the direct speaker call is not answered automatically, and the line remains in the ringing state.

The prevention of voice calling (speaker calls) can be enabled by the user with a function key or at the System Manager in the user profile. It is also possible to configure at the System Manager whether speaker calls should only be possible when no speech unit on an OpenScape Xpert terminal is in the call state (No voice calling during a call).

Direct answering

The handset microphone is turned on automatically if configured accordingly at the System Manager. The status of the handset microphone (on/off) is signaled in the speech unit field and on the Mute key.

If the handset microphone is not turned on automatically, this can be done manually by pressing the Mute key.

Direct answering block (applies to the entire terminal)

In this case, the handset microphone remains turned off at the subscriber who received the speaker call. The status of the "direct answering block" is signaled in the speech unit field and on the Mute key. The call can be answered by pressing the Mute key.

The direct answering block can be enabled by the user with a function key or at the System Manager in the user profile.

6 Features of a Line Group

This section describes the features of a line group.

6.1 Disconnecting All Lines

All existing connections at the OpenScape Xpert terminal can be disconnected simultaneously, including lines in the "Privacy" state and SPM lines.

As an exception, when other group members are using the lines or have parked these lines, these connections remain open.

An automatic disconnect of all connections occurs:

- when a subscriber logs in with the same profile at a second OpenScape Xpert terminal. A message appears indicating that all connections at the first OpenScape Xpert terminal have been disconnected.
- on enabling the "Receive Calls Only" function.
- on logging out (Logout).
- with the "Disconnect All Lines" key.

6.2 Line Sharing

Line Sharing refers to multiple entries into lines (OpenScape Xpert conference).

On shared lines, a maximum of 200 users can enter a call. This can be done at the same OpenScape Xpert terminal (parallel call) or via different terminals with the following keys:

- Line Key,
- New DKA
- Call Queue key

7 Features of the System Manager

This section describes the features of the OpenScape Xpert System Manager.

The System Manager is installed on a Microsoft Windows Server 2019 or Windows Server 2022 operating system.

The definition of the system topology and the configuration of components such as the MLC, terminals, etc., are handled separately in the so-called Topology Desktop. The components are presented graphically in a tree structure.

The basic configuration of the OS Xpert terminals is created in the so-called Configuration Desktop. The Configuration Desktop shows a graphical representation of the user profiles (grouped), feature catalog (selection of possible function keys), feature properties and user profile(s).

The pages of the user profile(s) are presented almost exactly as they appear at the OpenScape Xpert terminal (WYSIWYG).

As of OpenScape Xpert V5, the restriction of only one System Manager Admin per System Manager at a time has been removed. It is now possible to decrease the system configuration time by running multiple parallel System Manager Admins.

7.1 Administrator Roles and Permissions

The admin levels of System Manager are the following:

- Super Admins: full access to all components of the system.
- Profile Admins: can only configure Contacts and Profiles of the assigned groups.
- Technician: can only configure Profile and Topology.
- Operator: has read-only permission for Profile and Topology.

7.2 Presence List

Displays the presence list.

The profile names of the logged in OpenScape Xpert terminals, including those in the "Receive Calls Only" state, are displayed. The list does not provide any information on the call processing status of the logged in terminals.

7.3 Automatic Login after Release

The "Reestablish Login State After Release" parameter can be set in the Menu Properties at the System Manager so that the state of the profile is restored at the terminal after a release. The parameter applies system-wide and affects all profiles subject to a release. The number of profiles involved directly affects the resulting loss in performance and/or the time delays when logging in again.

7.4 Backup/Restore Function and Backup Wizard

The Backup/Restore function can be used to back up the Open Scape Xpert database on the System Manager to the hard disk of a local or network drive and subsequently restore it from there.

Functions:

- Create Backup (save the database)
- Scheduled Backup (creating daily backups of the database)
- Restore Backup (restore the database)

7.5 Export/Import Functions

OpenScape Xpert offers several different Export and Import functions:

- Import:
 - Lines,
 - Voice recording channels,
 - Global contacts (+Scheduled daily import)
 - Profile contacts
 - DKM keys
- Export:
 - Lines,
 - Voice recording channels,
 - Selected Profile contacts
 - DKM keys

Contacts

In the open communication solution for the OpenScape Xpert system, it is possible to import contact entries of the global or local Contact groups manually from a file.

Before importing the global contacts the overwrite behavior must be defined (Overwrite any existing having the same "Name" or "Call Number") in the process.

By checking "Remove All not imported" the administrator can fully synchronize imported data with affected global contact groups or profile contacts.

Import Global Contacts ?

i Select only UTF-8 encoded CSV file

Filename **Browse...**

Overwrite Behavior ▼

Remove All not Imported

OK **Cancel**

Features of the System Manager

The Import file must be available on the administrator's computer and it is uploaded to the SM at the beginning of the import process.

The CSV file must be UTF8 encoded and can be comma or semicolon separated. Group, Name and Number are mandatory fields, all other fields can be empty. In this case default values will be filled. The imported data will be applied to change the database only if no errors occur. If the import fails for any reason the whole import is refused and a message box appears with the error description.

Example CSV:

```
Group,Name,Number,Field3,Field4,Color,Partner Recognition  
Group1,John Smith,005552345667,floor 3,developer,2,true
```

Global contact import can be started as a scheduled daily job. In this case the import file should be placed on the server named "GlobalContacts.csv".

Scheduled Daily Import of Global Contacts

Import file on server: ProgramData\Unify\OpenScapeXpert\import\GlobalContacts.csv

Overwrite Behavior: Overwrite if number is the same

Remove All not Imported:

Execute Time: 15:35

Broadcast After Import: Notification only

Save Cancel

Importing/Exporting Lines

The configured speech lines are listed under the Lines menu in the System Manager. The table contains one row for each speech line.

The **Export function** can be used to export all lines basic data to an Excel (xlsx) file. The export file will be offered for download for the user. The download procedure is depending on the browser. The export file contains the following:

- Line ID
- Line Name
- URI
- Registrar ip:port
- SIP proxy ip:port
- Realm
- User name
- Password
- Assigned MLC node address (and alias name if set)

	A	B	C	D	E	F	G
1	Id	Name	URI	Registrar Ip	SIP proxy ip	Realm	User name
2	8589934714	5490	3616015490	192.168.10.102:5060	192.168.10.102:5060		
3	8589934718	5491	3616015491	192.168.10.102:5060	192.168.10.102:5060		
4	8589934726	5492	3616015492	192.168.10.102:5060	192.168.10.102:5060		
5	8589934730	5493	3616015493	192.168.10.102:5060	192.168.10.102:5060		
6	8589934734	5494	3616015494	192.168.10.102:5060	192.168.10.102:5060		
7	8589934738	5495	3616015495	192.168.10.102:5060	192.168.10.102:5060	realm	User1
8	8589934702	5496	3616015496	192.168.10.102:5060	192.168.10.102:5060		
9	8589934706	5497	3616015497	192.168.10.102:5060	192.168.10.102:5060		
10	8589934710	5498	3616015498	192.168.10.102:5060	192.168.10.102:5060		

The **Import function** can be used to create lines or change line settings.

The Import function can be used to create or modify lines from a locally stored Excel file. The format of the file must be the same as the export function output. At the begin of import the file is uploaded to the SM server.

If a line is created or modified is controlled with the Line ID.

- When the Line ID field is left blank, a new line is created.
- When the Line ID field contains a valid existing Line ID the line is modified in the database.

During import the Assigned MLC column is ignored, the line will not be assigned to an MLC.

The imported data will be applied to change the database only if no errors occur. If the import fails for any reason the whole import is refused and a message box appears with the error description.

7.6 User Profile

Every OpenScape Xpert terminal can be loaded with a customized user profile, which is initiated by the login.

The stored profile data includes the number of handsets/loudspeakers, the SPM configuration, page layouts, which lines are assigned to the OpenScape Xpert terminal, etc. The user profiles can be created individually at the System Manager via a menu-driven graphical user interface.

Functions

- Set up profile
- Select profile
- Create profile
- Clone profile
- Rename profile
- Move profile
- Delete profile
- Edit profile
- Configure profile group
- Create profile group
- Rename profile group
- Delete profile group
- Grouping profiles
- Set up function and line keys

Features of the System Manager

Line Group Overflow

- Function catalog for keys (function and line)
- Function selection
- Assign function to profile
- Assign lines to profile
- Configure number of HS
- Configure default page
- Attribute settings for keys (default)
- Edit keys and pages
- Copy key
- Paste key (Cut/Paste)
- Delete key
- Create new page
- Label / Rename page

7.7 Line Group Overflow

Line groups are configured for an OpenScape Xpert system and can be cascaded in multiple levels. The cascading of line groups at the System Manager server and for the OpenScape Xpert terminal also provides the functionality of a line group overflow for outgoing calls.

The cascading of line groups and the corresponding settings define the sequence in which lines are seized in and across the line groups for all profiles of an OpenScape Xpert system.

Line Seizure Sequence

Different settings are possible here.

For example: first select own lines of the same line group, followed by lines of the upper line group, and so on, until the root of the line groups and the lines configured there.

The behavior of lines in a line group (e.g., group B) can be defined at the SM:

- Overflow to Upper Group: If no further line is free in the group, and this parameter is activated, an attempt is made to find a free line in the next upper group. This is not activated by default.
- Use Neighbor Line within Same Group: An attempt is made to find a free line in the own group. This is activated by default.
- Seize Random Line instead of Preselected Line: The system does not use the default line assigned to the OpenScape Xpert terminal, but another line of the same line group. This line is selected at random.

7.8 Loading the System Configuration (MLC and Trading Terminals)

Every change in the system configuration after save is stored in the database. The clients and MLCs will read the saved data at startup, but the running devices will only load the new data when a "Broadcast Changes" is performed.

When the Broadcast Changes is executed, all MLCs will receive the latest data from the database, and all OpenScape Xpert clients will check if there is new data to load. When the data is loaded to the terminals depends on the type of the broadcast:

- **Forced Logout:** Data is loaded immediately. All affected terminals are logged out and, depending on the setting of the SM, returned to the state before the logout.
- **Logout Request:** The user receives a pop-up window and can accept or reject the change in the configuration. If the "Release" is rejected, the profile will only be updated after a logout/login or refresh of the profile at the terminal.
- **Notification Only:** The user receives information on the status bar of the terminal. The profile is updated only after a logout/login or refresh at the terminal.
- **Scheduled:** Broadcast type can be any of the above listed, execution time and date can be configured

7.9 Master Password for Service

A so-called master password can be defined for a system by the "User Administrator" at the System Manager. This password enables service technicians to log in at an OpenScope Xpert terminal within a system. The "master password " has the same rights as the password of the profile user.

The master password can only be enabled or disabled at the System Manager. The password consists of 5 to 15 characters. The input of the password is shown at the user interface hidden under asterisks. The activation of a master password applies simultaneously to the profile login, logging into the Contacts and the call memory. By default, the master password is disabled.

7.10 Migration of the Database

Database from V5.1 to V6 can be migrated. Older versions first needs to be upgraded to V5.1 and then upgraded to V6. It is possible to migrate from Trading 300 (Hicom Trading Classic) and HiPath Trading V1.1, V2.1, V3.0 and older OpenScope Xpert versions.

Trading 300 (Hicom Trading Classic)

The Contacts and DKA keys can be exported with the aid of a software tool (b8k_sig.exe). This exported data can be edited and then imported into the database (profiles or profile groups) of OpenScope Xpert.

HiPath Trading V1.1, V2.1, V3.0 and OpenScope Xpert Versions before V4 - > Latest V5Version

Databases of older versions can be migrated. Older versions < 3.0.5 must be migrated via the intermediate step of V3.0.5.

The topology of the TDM system is migrated, but not automatically converted to an IP topology.

The profiles of V3.0.5 or later versions can be migrated and remain configured with TDM lines of the SLMY.

Features of the System Manager

Multiple Changes to the User Profile

The IP lines of the MLCs are created as new lines by the system administrator. The TDM lines (SLMY) of the profile must be manually replaced by deleting the TDM line (MLC) and creating the new IP line (MLC) per profile or by using the "Search/Replace" function to replace one or more (selected) or all profiles.

7.11 Multiple Changes to the User Profile

Changes to keys and their functions can be made globally for all user profiles and profiles of user groups or individually for one or more manually selected user profiles or even specifically for each individual user profile.

7.12 Online Help

The online help contains explanatory details and further related topics on the usage and administration of the System Manager.

7.13 Login / Logout

After installation the login to the System Manager can be done with a default user. This default user can not be changed, however the System Manager can be configured that the login credentials are authenticated against an LDAP server. The configuration is described in the Service Manual.:

7.14 Remote Administration and Diagnosis

The administration interface is a web application that can be accessed using a web browser. The following browsers are supported: Edge, Chrome and Firefox.

For most operations, this interface is sufficient, but certain tasks may require remote desktop access, for example:

- Backup database
- Restore database
- Upgrade of System Manager
- Operating Cluster

This access is enabled for administration and for providing support when changes are made in the installation or configuration.

- Using remote access, the user interface of the system administrator can be shown on the own PC over a LAN. All actions are possible via remote access..
- Using a modem or TCP/IP connection and the application software "pcANYWHERE", any service technician or customer system support representative can dial into the System Manager from any PC after obtaining prior consent from the customer.

The dial-up connection occurs within the framework of the usual security mechanisms (e.g., with password protection).

7.15 Search, Replace or Delete

The Search, Replace or Delete function can be used to delete function keys, line keys and DK keys for one or more user profiles or to replace such keys with other keys.

7.16 Installing and Uninstalling

The OpenScape Xpert System Manager program can be installed and uninstalled on a server PC.

7.17 System Manager Cluster

System Manager Cluster is a successor of the NDSA (New Distributed Server Architecture) feature, with advanced capabilities. Cluster allows more System Managers to be used in one OpenScape Xpert system.

Overview

Big companies are usually located across multiple locations. NDSA provides the following:

- The System Manager servers can be at geographically separated locations and must be linked via a LAN/WAN connection.
- All users can access the main functions across the entire system with their own account.
- A System Manager server for the OpenScape Xpert clients can be provisioned to take over if a System Manager server should be unavailable for some reason.
- Client-to-client features like *Busy Indication* or *RingTransfer* will be available between the locations.

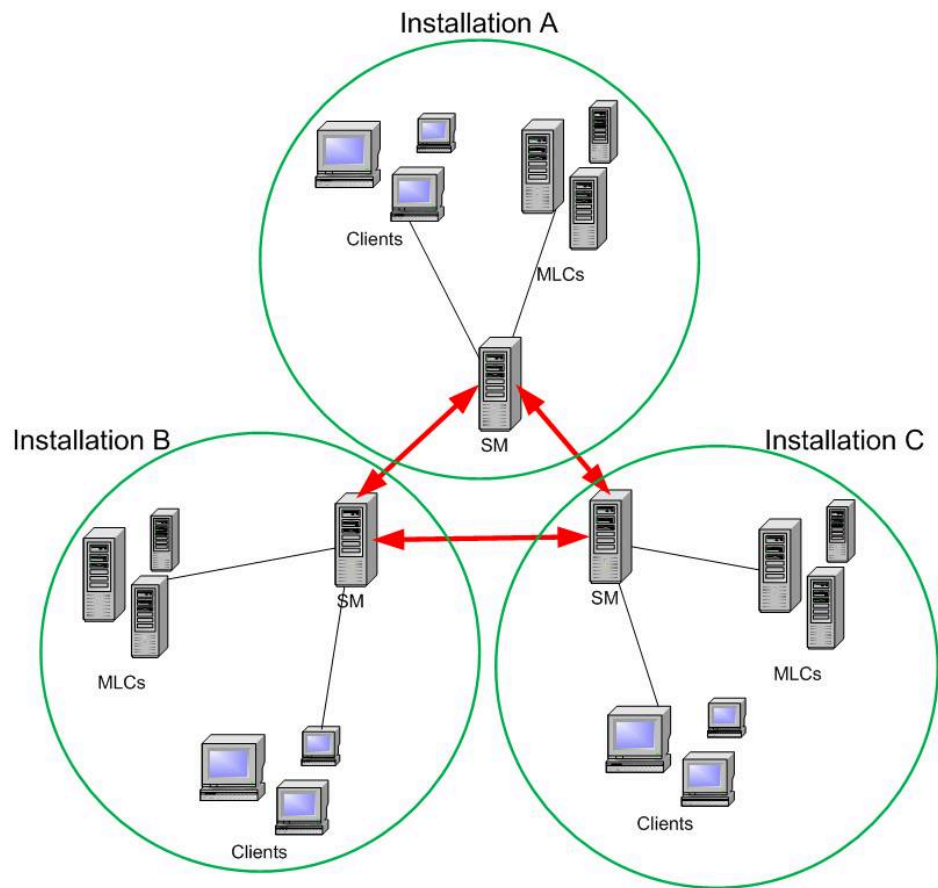

Prerequisites

- For the NDSA at least two System Managers are mandatory.
- The System Managers could be geographically separated and connected with a LAN/WAN connection.
- This solution can also be used for a standby/backup server solution.
- The System Managers to be connected must have exactly the same version installed.
- Every System Manager is accessible for the SM, the OpenScape Xpert clients, and the MLCs of the remote site via TCP (HTEMS).

Data Replication

After attaching System manager to a cluster the data replication is done immediately after the data is saved to the database without any additional action.

Failover / Fallback

If the local System Manager becomes unavailable, the connected OpenScape Xpert clients will connect to the System Manager with the highest priority in the priority list. If two or more System Managers have the same priority, the OpenScape Xpert clients will randomly select any target SM from these System Managers.

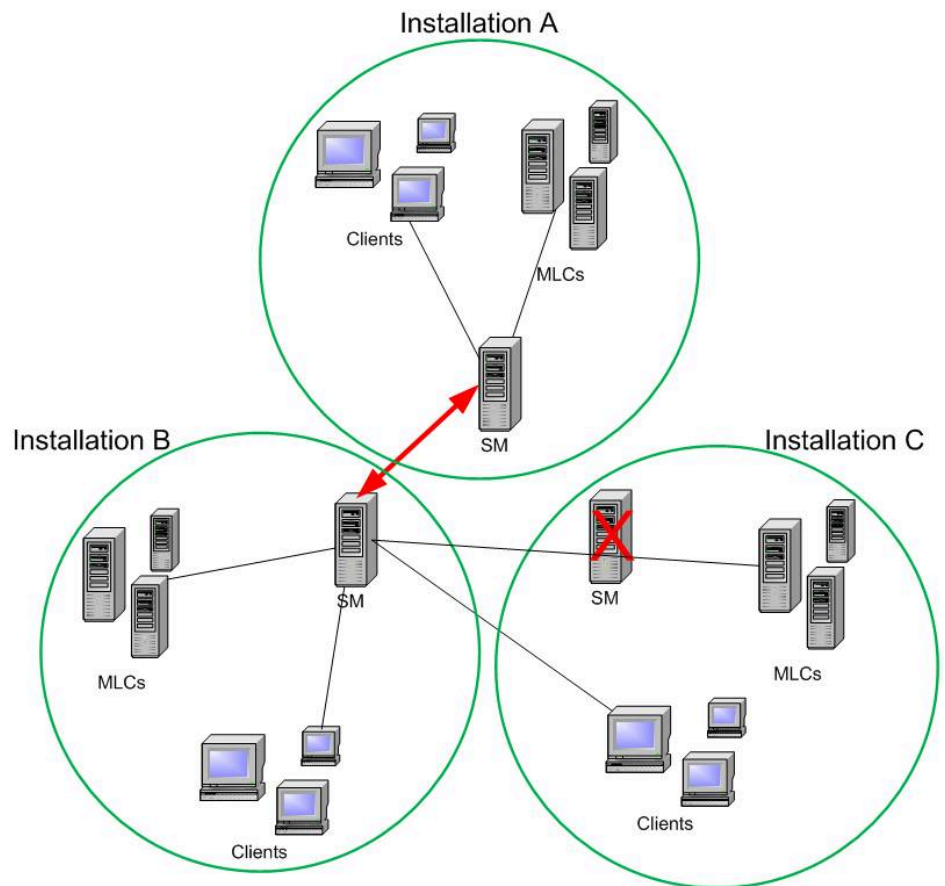

If the OpenScape Xpert client is connected to a backup System Manager, and the primary System Manager becomes available again, the OpenScape Xpert client will switch back to the primary System Manager.

When OpenScape Xpert Clients are connected to a backup SM all functions are available. Reading and writing any data to the database is possible. After the primary server is up again, all data written to a backup System manager will be immediately replicated.

7.18 Perpetual Licenses

Licenses are reserved at OpenScape Xpert Login therefore only number of licenses are necessary as many clients are logged in at the same time.

The licenses are reserved at login of the user and it will be released at logout. The license is reserved in logged in and in Receive Calls Only state.

There are two types of licenses

- Basic Client license: All logged in clients will use 1 of this license
- Full Page license: All clients logged in with a profile with 3 or more pages will use 1 of this license

In case for any reason a client could log in and the system cannot reserve a license for it, the client will never be logged out forcibly but the client will not be able to re-login after he logged out.

7.19 Subscription Based Licenses

Subscription Based Licensing (SSL) or Pay as you go (PAYG) is becoming popular among software licensing concepts.

Apart from traditional (perpetual) licensing model, OpenScape Xpert will also support SSL/PAYG licensing model. In SSL/PAYG model, customers will be invoiced for the licenses they used. This facilitates extension operation simpler since customers do not have to decide the amount of the licenses before they use and therefore not need to extend any license in case of necessity.

The SSL/PAYG model uses the “periodically billing” concept that allows the customer may use as many licenses as desired for a specific period called “qualifying period”. During this period, the amount of licenses used is recorded as report by licensing components and eventually invoiced to the customer. This means that the customer pays according to the amount of the licenses which have been used in that period. This qualifying period information is included in the license file within the **ssl_reporting** tag. To use this feature, a permanent internet connection is necessary between the CLA and CLS.

7.20 Central License Server

All OpenScape Xpert licenses can be stored for a customer on one server. This server can be used to provide licenses for all System Managers in Cluster or even for different systems.

The license server can be a dedicated server without using other System Manager services or can be used on the System Manger server.

When the license server is not accessible the System Manager will provide temporary licenses for the clients up to the number it was available in the License server at the time of last successful access. These temporary licenses are only valid for the 30-day grace period. The license server issues must be solved within this time frame.

8 Multi-Line Controller (MLC)

The OpenScape Xpert Multi-Line Controller (MLC) is the heart of the OpenScape Xpert system. It provides the features and IP interfaces to all other components.

The MLC is based on a standard server PC with Ubuntu operating system. The services needed to run the OpenScape Xpert MLC application should have been started on the server PC.

PBX Independent

OpenScape Xpert requires the SIP Subscriber Protocol to connect the system to a telephony system (PBX).

8.1 Operating System and Services

The OpenScape Xpert Multi-Line Controller MLC is the heart of the OpenScape Xpert system. It provides the resources, features and IP interfaces to all other components.

The MLC is based on a standard server PC with the Ubuntu operating system.

8.2 Session Initiation Protocol (SIP)

OpenScape Xpert requires the SIP Subscriber Protocol to connect the system to a telephony system (PBX).

Supported IETF standards:

RFC	Description
RFC 2474	Definition of the Differentiated Services Field (DS Field) in the IPv4 and IPv6 Headers
RFC 2327	Session Description Protocol (SDP)
RFC 3261	SIP: Session Initiation Protocol
RFC 3262	Basic Call
RFC 3264	Basic Call
RFC 3550	RTP: Transport Protocol for Real-Time Applications
RFC 3711	The Secure Real-time Transport Protocol (SRTP)
RFC 3515	The Session Initiation Protocol (SIP) Refer Method
RFC 4028	Session Timers in the Session Initiation Protocol (SIP)
RFC 4594	Configuration Guidelines for DiffServ Service Classes

OpenScape Xpert is compatible with various PBX systems from different manufacturers. Further details are provided in the Release Notice.

8.3 Scalability

Shared Lines and Multiple MLCs affect the scalability of the OpenScape Xpert system.

NOTICE:

Please note that the number of MLCs and shared lines has an impact on the performance of the system. More information on this is contained in the document "Planning Guide System Limitations", which is available via the TopNet product home page.

Line Sharing

"Shared Lines" are enabled in the OpenScape Xpert system by signaling the call processing status of a line of an MLC to all OpenScape Xpert Client IP applications connected to it. By simply pressing a line key, for example, all OpenScape Xpert users of a system can speak on the same line (barge-in conference).

Multiple MLC

An OpenScape Xpert Client application (OpenScape Xpert terminal) can be connected to all MLCs in the IP network and use its lines. If an MLC fails or cannot be reached by the OpenScape Xpert terminal over IP, all lines of the MLC will be unavailable.

8.4 IPv4 Support

The OpenScape Xpert System supports IPv4 (Internet Protocol Version 4 as per RFC 791).

8.5 Digitizing Analog Audio Signals

Analog audio signals are digitized using pulse code modulation. The rules for digitization are defined in the form of codecs. OpenScape Xpert digitized as per G.711.

Overview

The OpenScape Xpert MLC uses G.711 (ITU-T Standard) for the digitization of analog audio signals. This codec offers good voice quality and minimal delays. The μ -law quantification method is supported between all OpenScape Xpert components and the SIP switch, for voice recording as well as in the MLC, and in the OpenScape Xpert terminal itself:

8.6 Early Media

Early media refers to media (e.g., audio and video) exchanged before a particular session is accepted by the called user.

Function Description

Tones are generated locally in OSX. Early media cannot be played because it would then hide the features of these local tones. The "Early Media Support" feature of OpenScape Xpert covers the following aspects:

- Cut off at the beginning of outgoing calls.
- Calling an audio feeder which plays audio in ringing state.

As soon as "180 Ringing" arrives, the MLC does not play its locally generated ringback tone. The audio stream coming from the PBX to the stream towards the OSX Client is played instead. The early media feature can be configured on the System Manager with the **Enable Early Media** checkbox in the **MLC Properties** dialog.

The screenshot shows the 'Edit MLC: 1.100.4.0' configuration window. The 'Connectivity' tab is selected, showing the following settings:

Outbound Proxy Settings	
Enable DNS SRV	<input type="checkbox"/>
SIP Outbound Proxy IP Address	<input type="text"/>
SIP Outbound Proxy Port	<input type="text"/>
DNS SRV Domain	<input type="text"/>
Response Transaction Timer [sec]	<input type="text" value="32"/>
Connectivity Check Timer [sec]	<input type="text" value="90"/>

SIP Settings	
Sip Transport Protocol	<input type="text" value="UDP"/>
SIP Registration Timer [sec]	<input type="text" value="0"/>
SIP Session Timer [sec]	<input type="text" value="1800"/>
MinSE [sec]	<input type="text" value="90"/>

Options	
Enable Early Media	<input type="checkbox"/>
Continuous-call BYE Timer [ms]	<input type="text" value="0"/>
Keypad Primary Line	<input type="text" value="[Do not use keypad]"/>

Buttons: Save, Cancel

8.7 Domain Name System Service (DNS SRV)

This section describes the DNS SRV support for MLCs in OpenScape Xpert V4R5 and higher.

Function Description

DNS SRV feature serves to increase the resilience of the whole OpenScape Xpert solution when connecting to the OpenScape Voice Resilient Telco Platform.

In former versions there was a single point of failure in the OpenScape Xpert infrastructure. The MLC could only address one single SIP Outbound proxy with a static IP address. If this configured SIP Outbound proxy was not reachable, then the lines on an MLC couldn't register, and no voice calls were possible on the respective lines.

With the DNS SRV feature, the MLC queries a list of SIP outbound proxies and OpenScape Voice systems from a DNS server and then selects the available route with the highest priority (survivability of OpenScape Voice).

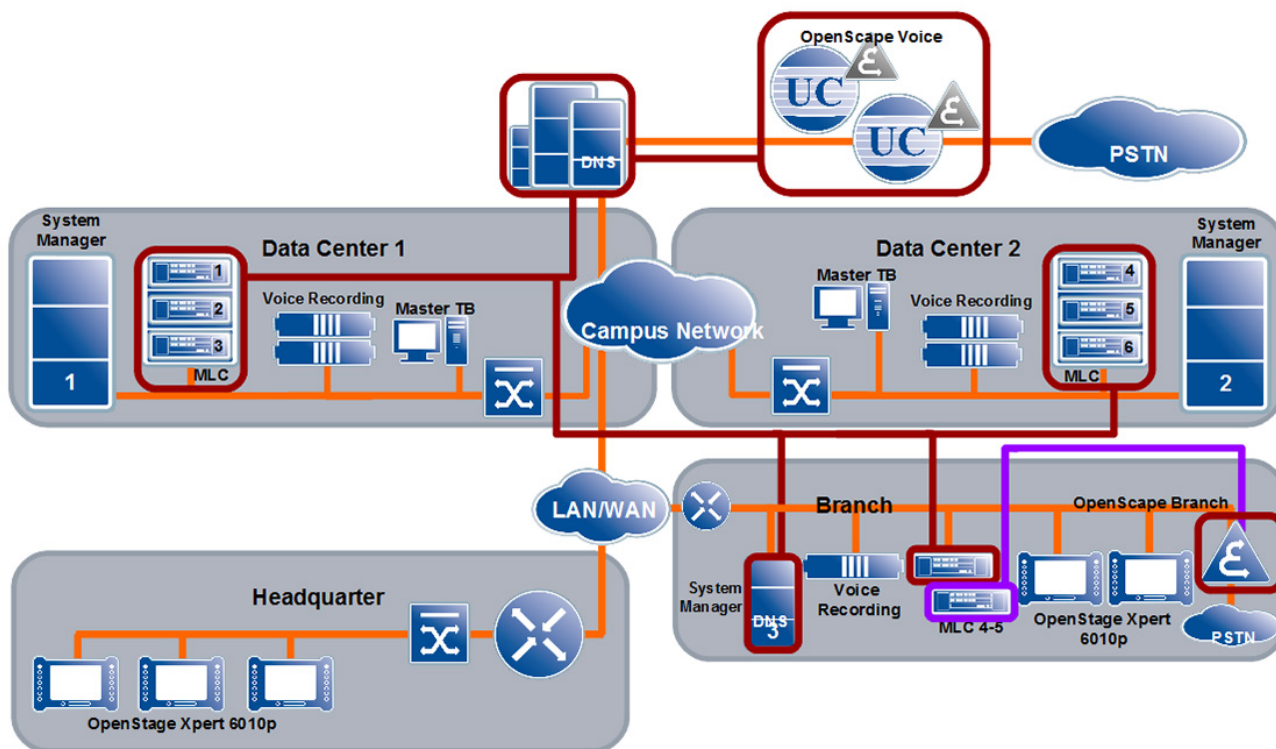

Prerequisites

- The domain with the SIP Outbound Proxies must be accessible from the MLCs. This is important because the MLCs first check the settings on the Domain Controller to know which are the SIP Outbound Proxies for UDP packages.
- At least two SIP Outbound Proxies have to be configured in the OpenScape Voice environment. The feature will work also with one SIP Outbound Proxy.

8.8 SIP over TCP

This section describes the SIP via TCP (Transmission Control Protocol) feature enhancements for OpenScape Xpert.

TCP or UDP?

- **TCP**

TCP is a connection-oriented protocol. A connection can be made from client to server, and from then on any data can be sent along that connection.

TCP will be the transport protocol for SIP signalization if the voice between the PBX and the MLC is encrypted.

- **Reliable**

When you send a message along a TCP socket, you know it will get there unless the connection fails completely. If it gets lost along the way, the server will re-request the lost part. This means complete integrity; things don't get corrupted.

- **Ordered**

If you send two messages along a connection, one after the other, you know the first message will get there first. You don't have to worry about data arriving in the wrong order.

- **Heavyweight**

When the low level parts of the TCP "stream" arrive in the wrong order, resend requests have to be sent, and all the out of sequence parts have to be reassembled and put back together, so this reassembly involves some overhead.

- **UDP**

A simpler message-based connectionless protocol. With UDP you send messages (packets) across the network in chunks.

- **Unreliable**

When you send a message, you don't know if it'll get there; it could get lost on the way.

- **Not ordered**

If you send two messages out, you don't know what order they'll arrive in.

- **Lightweight**

No ordering of messages, no tracking connections, etc. This means that it is a lot quicker, and the network card / OS have to do very little work to translate the data back from the packets.

Feature Handling

- On the **MLC Properties, General** tab a new field has been implemented where the SIP transport protocol can be set accordingly to the OSV setting. It is possible to choose between TCP and UDP.
- New timers will be introduced in the MLC to detect failing SIP Outbound Proxies.
 - Response Transaction Timer.

This timer will be set on each transaction start. When there is no response from the SIP Outbound Proxy within the given timeframe it

Multi-Line Controller (MLC) Quality of Service (QoS)

will be marked as failed and a failover will be started to the next highest priority SIP Outbound Proxy. Failed SIP Outbound proxies are put on a blacklist and the SM is notified so that it can report the event to the HiPath Fault Manager via SNMP trap if configured.

- Penalty Box Timer

SIP Outbound Proxies marked as failed will be tried to contact only after the Penalty Box Timer expires to prevent shaky connections triggering the MLC to switch SIP Outbound proxies continuously. SIP lines are independent when choosing an available SIP Outbound proxy. If the Penalty Box Timer expires for a failed SIP Outbound proxy, then the next line trying to send out a SIP message can contact it if it has the highest priority and is not on the blacklist.

- SIP Registration Timer

Time before MLC failure. If the SIP registrar is not available for the given timeframe, the lines from the affected MLC will be deactivated.

8.9 Quality of Service (QoS)

This section describes the "Quality of Service (QoS)" feature for OpenScape Xpert.

Overview

Packet prioritization has been implemented in OpenScape Xpert V4R5 to avoid bad voice quality. It is possible to change the QoS parameters depending on the customer's network architecture. The OpenScape Xpert Multi-Line Controller supports the Quality of Service (QoS) mechanism for prioritizing IP data packets using DiffServ (Differentiated Services as per RFC 2474, RFC 2475).

Prerequisites

- The customer's network switches must support QoS.
- In order for Layer2 QoS (VLAN Tagging, IEEE802.1q) to work on the MLC, the Linux server has to be configured to use VLANs

Feature Handling

The QoS can be configured in the System Manager: System Properties > General > Quality of Service.

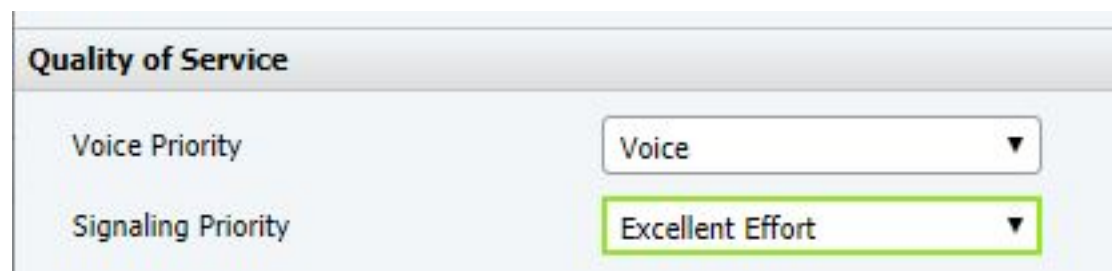

Quality of Service	
Voice Priority	Voice
Signaling Priority	Excellent Effort

8.10 Warm/Hot Standby MLC

This section describes the feature "Warm and Hot Standby MLC" for OpenScope Xpert.

Overview

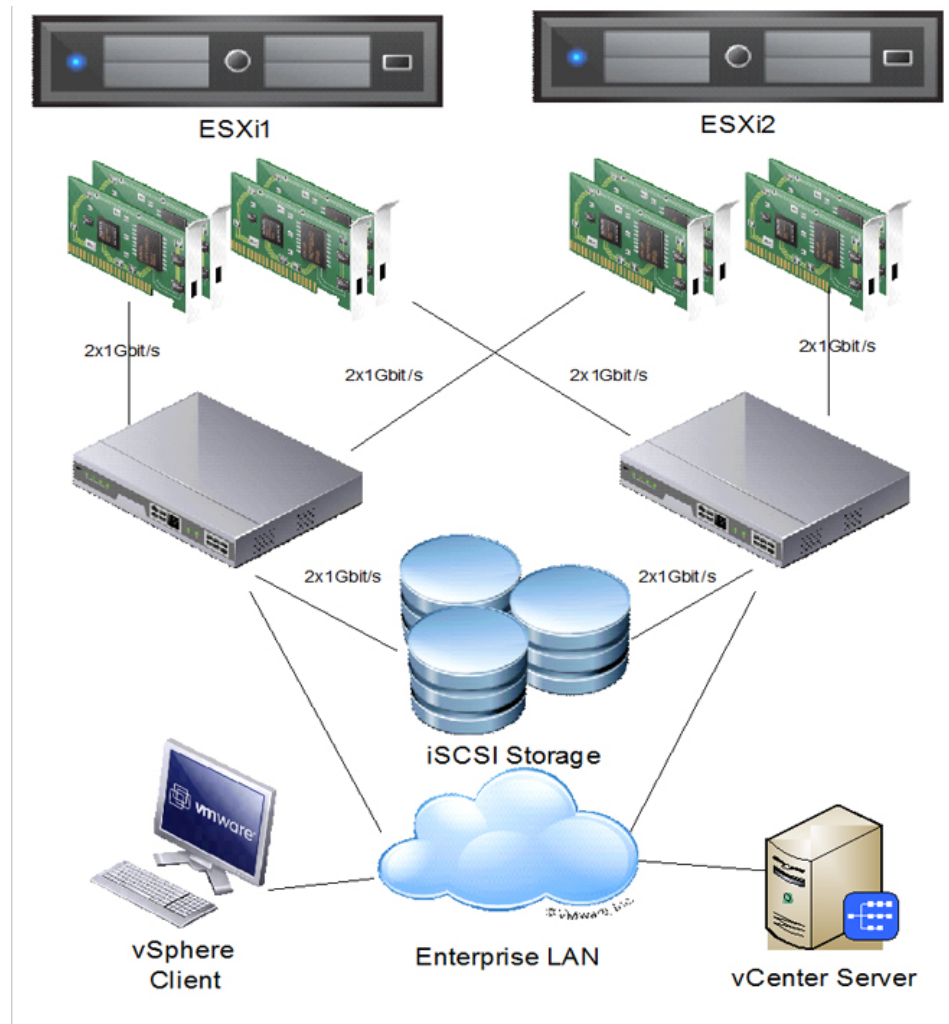

This feature provides continuous availability with the failover functionality "High Availability" and/or "Fault Tolerance" from VMware for virtual MLCs if a switch or a server fails.

Multi-Line Controller (MLC)

- **High Availability**

If a host fails, the High Availability feature tries to restart the VM MLCs on another available ESXi host.

- Cold standby virtual machine.
- Failover time a few minutes, depending on the startup time of the secondary VM MLC.
- Lines will be grayed out and calls are interrupted.

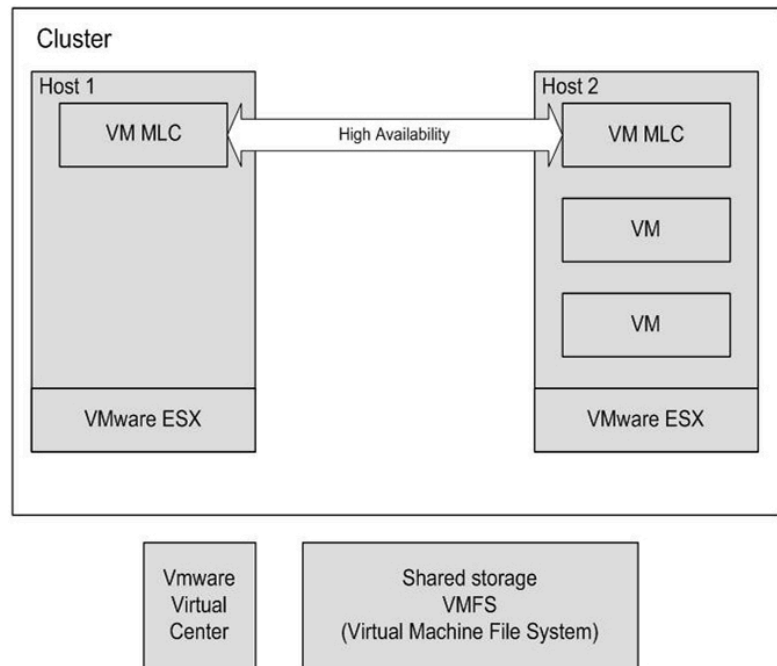

- **Fault Tolerance**

In case of a failure, the secondary VM MLC is immediately activated to replace the primary VM MLC. No call is interrupted.

- Hot standby virtual machine
- Processor instructions, memory operations, etc., are sent to the other VM.
- Secondary virtual machine is max. 10 ms behind primary machine.
- Failover time 0.5 sec.

NOTICE:

Please note that there are special restrictions on the performance of the system for fault tolerance. More information on this is contained in the document "Planning

Guide System Limitations", which is available via the TopNet product home page.

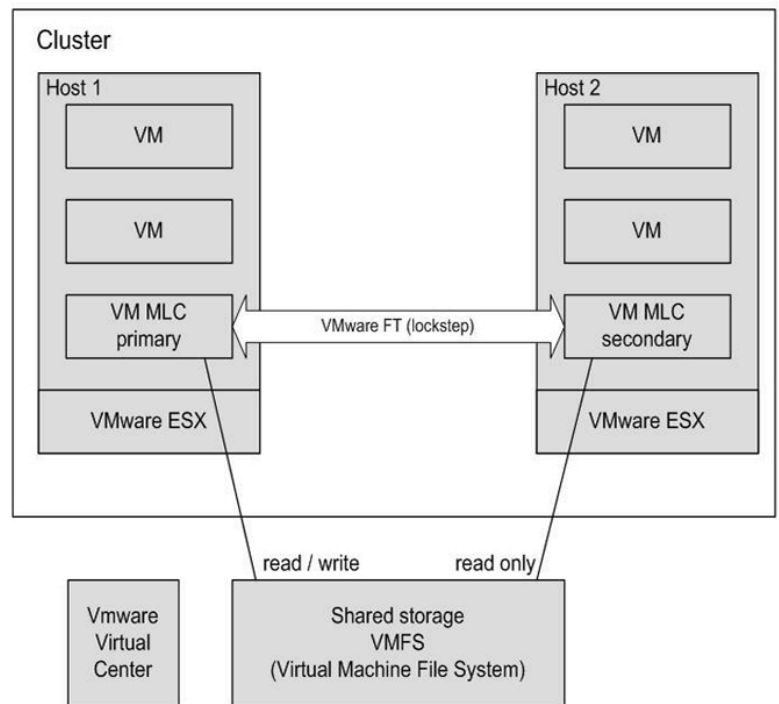

8.11 MLC Overload Protection

This section describes the feature "MLC Overload Protection" in OpenScape Xpert.

Overview

The MLC is a real-time system that handles voice calls. The upper limit of CPU usage specified by Unify for real-time applications is 80%. In order to ensure that the calls are handled properly and to prevent the voice quality from being impaired or the MLC from crashing, the MLC rejects additional calls and certain features on reaching a specific threshold.

Function

The MLC monitors the CPU usage of the computer on which it is running. As soon as a predefined limit is reached, the MLC switches to overload mode. In overload mode, new calls and features that would result in a significant additional CPU load are rejected. Most of the CPU load is caused by the RTP stream processes. Consequently, as a rule of thumb, it can be stated that all features which generate additional RTP streams will be rejected in overload mode.

Whenever the MLC switches to overload mode, this is indicated at the OpenScape Xpert terminal by an icon on the line or SPM keys affected.

Multi-Line Controller (MLC)

MLC continuous SIP Message Tracing

8.12 MLC continuous SIP Message Tracing

All MLC interfaces, including the SIP traffic, are encrypted since OpenScape Xpert V7. Wireshark captures of encrypted SIP traffic are unusable to analyze customer issues and customers are not expected to provide private keys to development for decrypting encrypted network traffic.

With the MLC continuous SIP Message Tracing feature the MLC application constructs virtual network traces from its SIP traffic in the PCAP capture file format. PCAP files are the native file format for Wireshark captures. The MLC constructed SIP trace PCAP files can be opened and analyzed in Wireshark.

8.13 Automatic redial

After the startup, the MLC must establish a call automatically to the configured destination in the SM **Continuous Call Destination** field on every line where the **Reestablish Continuous Call** check box is enabled. The MLC must always keep these calls even if all TTs disconnect or log out. The KillLine Function Key can only release these established calls. Once a call is released on these lines, dialing any number will reestablish the configured call.

In case of an unsuccessful call or the remote party is disconnected, the MLC does not reestablish the call automatically. In this case, the user must dial any number to reestablish the call manually.

8.14 Support of Unify Office Cloud lines

To configure the MLC to use Unify Office Cloud lines, you need to select **Unify Office** as the Operation Mode from the **Operation Mode** drop-down list under **MLC General Settings**.

Shared / Keypset lines are not supported with Unify Office Cloud lines.

8.15 Direct connection to Cisco PBX

Starting with V8 R0, the connection between MLC and Cisco is possible without having OSV in the middle.

To connect to Cisco directly, the configuration of MLC is the following:

- 1) Open MLC and locate **Operation Mode** area from the **Operation Mode** drop-down list under **MLC General Settings**
- 2) Select **Cisco Unified Call manager** from the **Operation Mode** drop down menu.

It is possible to use Cisco with TCP and TLS setting, but not with UDP.

Shared / Keypset lines are not supported with Cisco.

8.16 UDP hole punching

The UDP hole punching feature allows Turrets behind a NAT firewall to use a private IP address and be able to communicate with an MLC configured with a public IP address.

9 Application Programming Interface (CTI API)

This section describes the features of the CTI API interface. The CTI API interface enables external software to control the OpenStage Xpert client and retrieve data.

Functions (Selection)

Detailed information on the CTI API interface is contained in the document "CTI Interface Description".

- API Call State Ring Tone

The feature "API Call State Ring tone" enables the customer to check via API for a specific turret whether

- acoustic ringing is enabled for a specific line,
- a specific line is displayed in the call queue.

- Login via API

It is possible to log into the OpenStage Xpert client via the API interface with the Profile Name and Password.

- Logoff via API

It is possible to log off the OpenStage Xpert client via the API interface.

- Call control

It is possible to do the complete call control (pick up/hold/disconnect/dial) of outgoing and incoming calls via the API interface.

- Web Browser

It is possible to change the URL of a specific Browser Page via the API interface.

- Ring Transfer

It is possible to activate/deactivate and check specific Ring Transfer settings via the API interface.

- Contacts

It is possible to activate/deactivate and check specific Contact settings via the API interface.

- Radio Integration Remote Key

It is possible to change the first line of a Remote Key (Catalyst Radio) via the API interface.

- Call Logging (HTE)

It is possible to receive Data like Partner Number or Dialed Number sent via the API interface for:

- Master Tradeboard for Voice Recording
- Controlling Contact Interface
- Database application running on customer PC (popup window)

Multiple Connections via the API Interface

The OpenScape Xpert terminal has an open port via which external applications can establish a connection. Up to five applications can be simultaneously connected to the OpenScape Xpert terminal.

The multiple connection is realized only through the LAN port; it is not possible to connect simultaneously via the serial interface (COM port) or to operate multiple connections via the serial interface.

Messages that are sent by the OpenScope Xpert terminal to an application are transmitted to all the existing API connections at the same time.

Incoming messages from different API connections are collected in a queue and processed in order of receipt, regardless of the connection from which a message was received.

API Events with Connection Information

A new, extended information block has been added to the status messages for lines. This block contains the connection information. The following states can be distinguished:

- Not connected
- Connected
- Ringing
- Callback
- Unknown

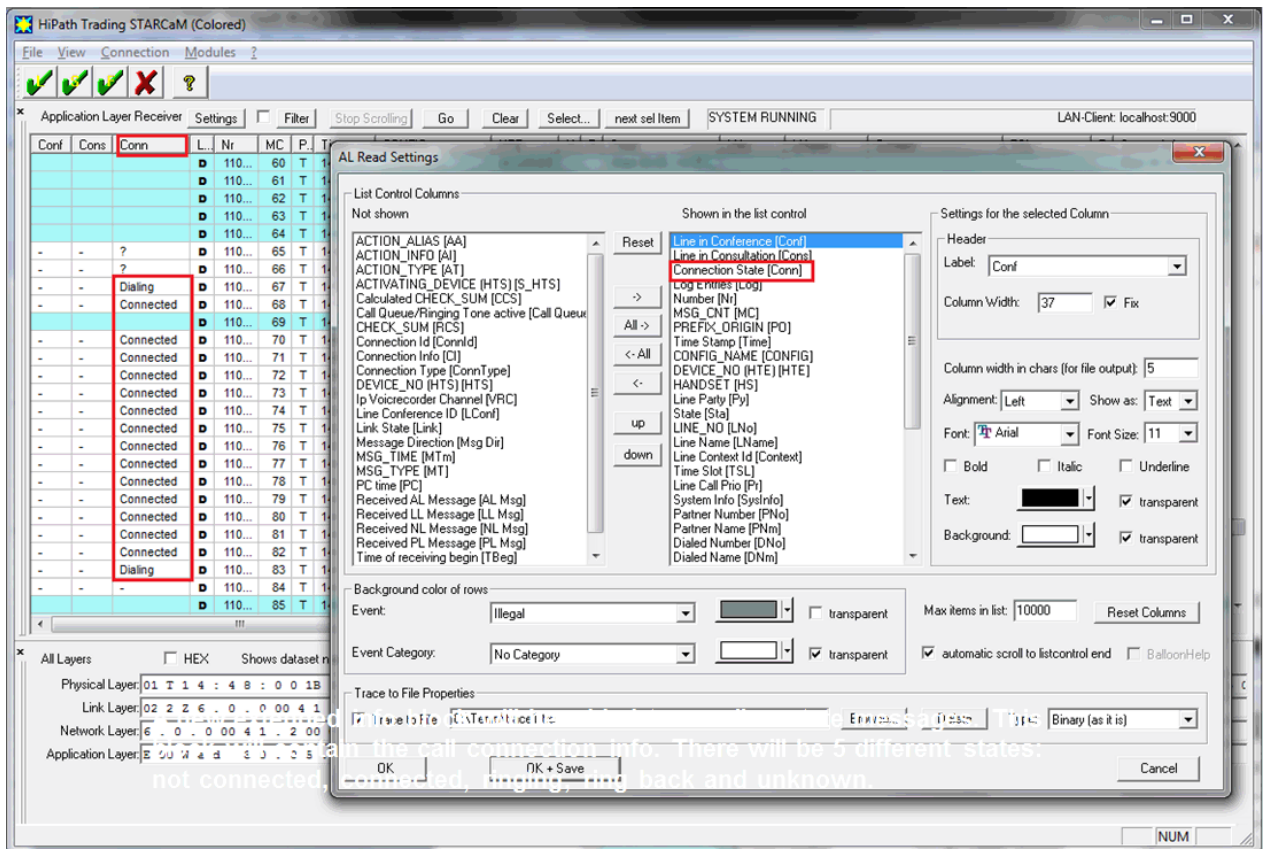

10 Thrift-Based API

This section describes the features of the new Thrift-based API interface. The API interface enables external software to control the OpenStage Xpert client and retrieve data, but a so called interface definition file is provided instead of a binary protocol.

Functions

- Login via API

It is possible to log into the OpenStage Xpert client via the API interface with the Profile Name and Password.

- Log off via API

It is possible to log off the OpenStage Xpert client via the API interface.

Basic call control functionalities

- make call

Requests the turret to dial the given number from the specified speech unit using a free/available line

- make call using a specific line

Requests the turret to dial the given number from the specified speech unit using a certain line.

- answer call

Answers the incoming call with the highest priority in the call queue.

- answer specific call

Answers the incoming call on the line specified by lineName.

- Disconnect call

Disconnects the call present on the speech unit specified by its ID.

- Ring Transfer

It is possible to activate/deactivate and check specific Ring Transfer settings via the API interface.

- Ring Transfer Sequence

It is possible to activate/deactivate and check specific Ring Transfer Sequence settings via the API interface.

- Interface Key

It is possible to change the state and the displayed text on an Interface Key via the API interface.

Asynchron notification from OpenScape Xpert client

- Line state changes

Notifies about the change of state of the specified line.

- Login state changes

Notifies about the login state change of the turret software.

- Login response

Notifies about an error during the login process.

- Call Queue change

Notifies a new incoming call having higher priority than the ones before, or if all incoming calls have been removed from the call queue.

Service

Secure Remote Access (Service) SiRA

11 Service

Several Service tools are available and allow high serviceability of the OpenScape Xpert systems.

11.1 Secure Remote Access (Service) SiRA

Secure remote access is provided by the Secure Remote Access System SiRA from Unify. OpenScape Xpert is released for SiRA.

11.2 Remote Patch and Update Process HiSPA

The standardized mechanism for applying patches/updates and activating the new software is provided by HiSPA from Unify. OpenScape Xpert is released for HiSPA.

11.3 Fault Management with CAP FM

For Service purposes the condition of the OpenScape Xpert system components can be displayed on the user interface at the System Manager client. The "HiPath CAP FM" software installation package is delivered with the HiPath OpenScape Xpert System software.

The OpenScape Xpert can send errors and warnings from the OpenScape Xpert System Manager to an SNMP or MIB host (HiPath Fault Manager) via the Simple Network Management Protocol SNMP by using a particular Management Information Base Definition MIB. With this feature, states of OpenScape Xpert hardware components can be monitored through an SNMP/ MIB host, e.g., HiPath Fault Manager. The following OpenScape Xpert objects can be monitored:

- MLC
- IP Turret

11.4 Central Image Distribution via Diagnosis Tool

The diagnosis tool provides the new functionality "Reboot turrets in Recovery Mode".

When this functionality is invoked, the turret reboots into a small Linux that runs from RAM. After that the DiagTool may command the device via ssh to make a backup or update the image on the HDD.

The following pictures shows the components involved:

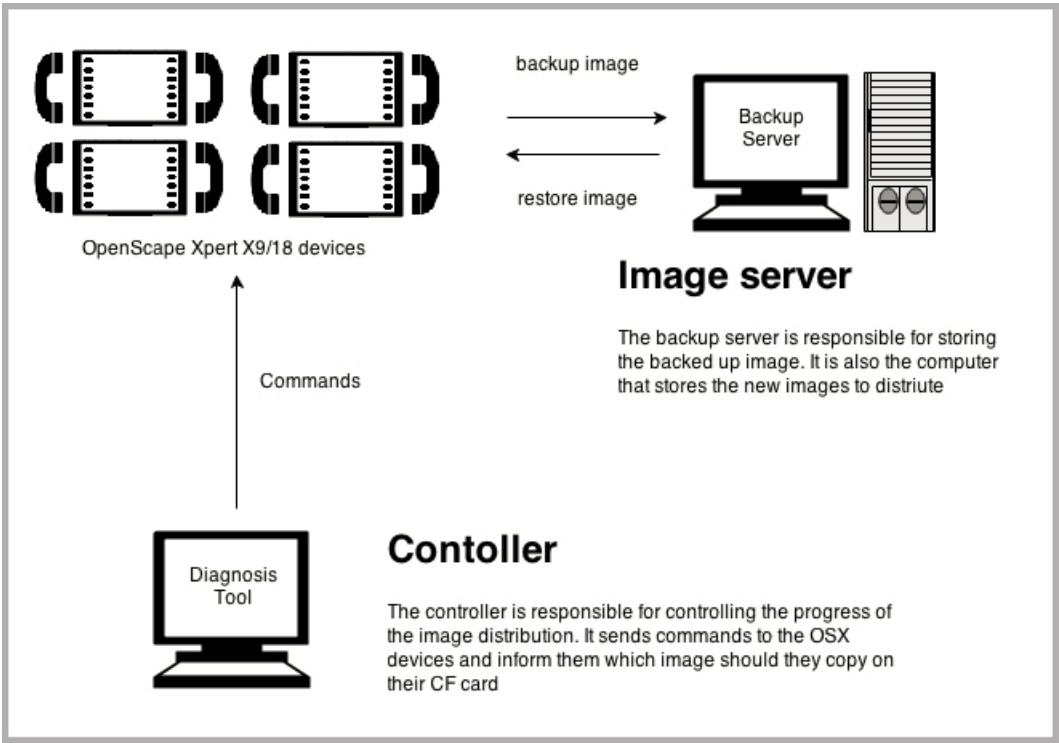

11.5 Virtual Network Computing (VNC)

You can use X11 VNC server to establish graphical connections to an OpenScape Xpert Linux client. In this way you can interact with the client GUI remotely. The X11 VNC server is pre-installed on all OpenScape Xpert Linux clients but it is disabled by default.

12 Limitations

The performance of the system depends on the system architecture as well as some other criteria.

Criteria that Affect Performance

The following parameters have an influence on the performance of the OpenScape Xpert system:

- Number of administrators who edit the database at the same time.
- Number of configured Direct Keys (DKM/DKA).
- Number of System Managers in an Cluster system.
- Number of MLCs that are configured at a System Manager.
- Number of terminals that are assigned to a System Manager.
- Number of trading groups that are configured at a System Manager.
- Number of MLCs are configured at a system.
- Number of supported profiles per System Manager.
- Busy hour call completion (BHCC) code per MLC.
- Number of RTP streams per MLC for virtualized systems.
- Number of subscribers who use a shared line at the same time.
- Number of terminals that are connected to an MLC.
- Number of shared lines per MLC.
- Number of lines that are configured at an MLC.
- Number of voice recorders that are configured at a System Manager
- Additional criteria

NOTICE:

More information about the limitations is contained in the document "Planning Guide System Limitations", which can be obtained via the TopNet product home page and is always made available with the current values at that location.

12.1 Applications at OpenScape Xpert Terminals

In general, other applications can be installed and run on the OpenScape Xpert device. However, since the resources of the client PC are limited (e.g., CPU load, memory usage, video resources, LAN bandwidth, etc.), this may affect performance.

OpenScape Xpert has therefore been released only with the applications tested by Unify. See also the Release Notice and compatibility list for OpenScape Xpert. The use of other applications at OpenScape Xpert terminals is not prohibited, but the performance, quality and availability of OpenScape Xpert can then no longer be assured. Other applications can be tested and released with OpenScape Xpert by Unify on a project-specific basis or in general on request.

Index

A

- active control [34](#)
- Admin Roles [84](#)
- announcement indicator [65](#)
- API [106](#)
- API, thirft based [108](#)
- Application Programming Interface (API) [47](#)
- applications at terminals [112](#)
- assignment of speech unit:automatic [32](#)
- assignment of speech unit:fixed [32](#)
- assignment of speech unit>manual [32](#)
- Attendant list [14](#)
- authentication [18](#)
- automatic answer (AA) [73](#)
- automatic echo cancellation [58](#)

B

- backup / restore [85](#)

C

- call control field [31](#)
- Call Forward ON and OFF [69](#)
- call memory (call journal) [17](#), [17](#), [77](#)
- call queue [14](#)
- Central license server [94](#)
- close the application [62](#)
- Cluster [80](#)
- codec [96](#)
- color settings for DKA [24](#)
- Computer Telephony Interface (CTI) [18](#)
- contact interface (CI) [19](#)

D

- Date and time [58](#)
- dialing delay [62](#)
- direct keys [22](#)
- disconnect [29](#)
- disconnect all lines [83](#)
- DNS SRV [98](#)

E

- E911 support [64](#)
- Early Media [97](#)
- echo cancellation [58](#)
- emergency calls [64](#)
- encryption at the terminal [26](#)
- export/import:Contacts [85](#)
- export/import:speech lines [86](#)

F

- Fault Management [110](#)
- feedback tone [61](#)
- forced disconnect [33](#)
- Forced Logout [89](#)
- free seating [81](#)
- freely programmable keys [26](#)
- function key:1st ring tone [44](#)
- function key:alternate outgoing number [75](#)
- function key:different dial prefix [75](#)
- function key:Hold Concentrator [75](#)
- function key:ring transfer [44](#)
- function key:ring transfer sequence [46](#)

G

- G.711 [96](#)
- Go to Page keys [42](#)

H

- hardkeys [57](#)
- HiSPA [110](#)
- hold [35](#)
- hold:automatic [35](#)
- hold>manual [35](#)
- Hoot-n-Holler [61](#)

I

- IETF standards [95](#)
- Incoming Call Concentrator [76](#)
- indicator, announcement [65](#)
- intercom [81](#)

K

- keys on the unit [57](#)

L

- languages [46](#)
- license concept [93](#)
- License server [94](#)
- line group overflow [72](#), [88](#)
- line seizure:automatic [71](#)
- line seizure:comfort activation [71](#)
- line sharing [96](#)
- loading the system configuration [89](#)
- logging in and out of the SM [90](#)
- login [38](#)
- logout [38](#)

Logout Request [89](#)

M

macro delay key [40](#)
Macro key [39](#)
master password [89](#)
menu buttons [40](#)
migration of the database [89](#)
Multi-Line Controller (MLC) [95](#)
multi-streaming [54](#)
multiple login [38](#)
multiple MLCs [96](#)
mute [33](#)
muting [33](#)

N

NDSA2 [91](#)
Notification Only [89](#)
number of the speech unit [63](#)
number pad (dial pad) [28, 28](#)

O

online help [56, 90](#)
open listening [26, 26](#)
operating system MLC [95](#)

P

Page Signaling Parameter [42](#)
Perpetual licenses [93](#)
Preferred Identity Number [78](#)
presence list [14, 84](#)
prevention of voice calling (speaker calls) [82](#)
privacy [73](#)
Private Hold [35](#)
Profile [87](#)
progress control [34](#)

Q

QoS, Quality of Service [100](#)
Quality of Service [100](#)
queue (calls) [14](#)
Quick Conference [76](#)

R

re-ring signal [61](#)
recall [76](#)
Receive Calls Only [43](#)
redial [37](#)
remote administration [90](#)
remote maintenance [90](#)
ring tone (ringer) [43](#)

ring tone off [63](#)
ring tone, setting in call state [43](#)
ring transfer at the terminal [45](#)
ringer (ring tone) [43](#)

S

Scheduled [89](#)
scheduled logout [39](#)
screen resolution [56](#)
Screensaver [66](#)
shared line [83](#)
SIRA [110](#)
speaker call:incoming [81](#)
speaker call:outgoing [81](#)
speaker module [58, 58](#)
speech monitoring (SPM) [51](#)
speech monitoring:assign line automatically [52](#)
speech monitoring:assign line selectively [52](#)
speech monitoring:change assignment [52](#)
speech monitoring:delete assignment [53](#)
speech monitoring:disconnect SPM line [53](#)
speech monitoring:mute [51](#)
speech monitoring:save/load SPM assignments [53](#)
speech monitoring:time of persistence [51](#)
speech unit [31](#)
speech-sensitive signaling [51](#)
SPM channels [65](#)
SPM-to-handset [64](#)
Subscription Based Licenses [94, 94](#)
suffix dialing for DKM [62](#)
system components [9](#)

T

TAPI interface [47](#)
telephone directory [49](#)
telephone directory:configuration groups [50](#)
telephone directory:extended entries [50](#)
telephone directory:global [49](#)
telephone directory:partially qualified search [50](#)
Thrift-based API [108](#)
toggle [72](#)
Tones for dialing, ring back or busy [57](#)
tool bar [40](#)
trunk seizure:specific [71](#)

U

U.S. call tones [58](#)
UC integration [65](#)
Usability Improvements [67](#)
user mode [56](#)
user profile [87](#)

V

Virtual network computing [111](#)
voice recording [53](#), [74](#)
voice recording:per line [74](#)
volume normalization [63](#)

W

warm and hot standby [101](#)

