



A MITEL
PRODUCT
GUIDE

MiVoice Business

Hardware Technical Reference Manual

Release 10.5
Document Version 1.0

October 2025

Notices

The information contained in this document is believed to be accurate in all respects but is not warranted by **Mitel Networks Corporation (MITEL®)**. The information is subject to change without notice and should not be construed in any way as a commitment by Mitel or any of its affiliates or subsidiaries. Mitel and its affiliates and subsidiaries assume no responsibility for any errors or omissions in this document. Revisions of this document or new editions of it may be issued to incorporate such changes. No part of this document can be reproduced or transmitted in any form or by any means - electronic or mechanical - for any purpose without written permission from Mitel Networks Corporation.

Trademarks

The trademarks, service marks, logos and graphics (collectively "Trademarks") appearing on Mitel's Internet sites or in its publications are registered and unregistered trademarks of Mitel Networks Corporation (MNC), its affiliates, parents, or subsidiaries (collectively "Mitel") or others. Use of the Trademarks is prohibited without the express consent from Mitel. Please contact our legal department at legal@mitel.com for additional information. For a list of the worldwide Mitel Networks Corporation registered trademarks, please refer to the website: <http://www.mitel.com/trademarks>.

®,™ Trademark of Mitel Networks Corporation

© Copyright 2025, Mitel Networks Corporation

All rights reserved

Contents

1 Introduction.....	1
1.1 Important Safety Instructions.....	1
1.2 New Hardware.....	2
1.2.1 Supporting Documentation.....	2
2 3300 ICP Controllers.....	3
2.1 Controller Types.....	3
2.1.1 Optional Components.....	4
2.2 AX Controller.....	4
2.2.1 Standard Configuration for AX.....	6
2.2.2 Optional Configuration.....	6
2.3 Mx Controller.....	7
2.3.1 Standard Configuration for Mx.....	9
2.3.2 Optional Configuration.....	9
2.4 CX II and CXi II Controllers.....	10
2.4.1 10/100 802.3af LAN Ports (CXi II).....	11
2.4.2 Front View - CX(i) II Controllers.....	11
2.4.3 Rear View - CX(i) II Controllers.....	12
2.4.4 Standard Configuration for CX(i) II.....	13
2.4.5 Optional Configuration.....	13
2.5 Connections.....	14
2.5.1 RS-232 Ports (Printer and Maintenance).....	14
2.5.2 Copper Interface (Embedded and MMC) Ports.....	15
2.5.3 Ethernet ports.....	16
2.5.4 Alarm Port.....	17
2.6 Field Upgradeable and Replaceable Controller Modules (AX, Mx, CX(i) II).....	18
2.6.1 Stratum 3 Clock Module.....	19
2.6.2 Mx Processor (E2T/RTC).....	20
2.6.3 Digital Signal Processor Modules.....	20
2.6.4 Echo Canceller Module.....	20
2.6.5 Quad Copper Interface Module (CIM).....	21
2.6.6 Dual T1/E1 Framer.....	21
2.6.7 T1/E1 Combo Card.....	25
2.6.8 Quad Basic Rate Interface (BRI) Framer.....	27
2.6.9 AX and ASU II Specific Modules.....	29
2.6.10 Analog Boards.....	33
2.6.11 Music on Hold and Paging Specifications.....	50
3 Services Units and Gateways.....	55
3.1 Analog Services Units.....	55
3.1.1 Analog Services Unit II (ASU II).....	56
3.1.2 Analog Services Unit.....	57
3.1.3 Universal Analog Services Unit.....	58

3.2 ASU II Transmission Standards.....	62
3.3 Circuit Descriptions.....	63
3.3.1 Loop Start Trunks.....	66
3.3.2 System Fail Transfer (SFT).....	66
3.4 Pin Allocations.....	67
3.4.1 ASU and Universal ASU Line and Trunk Connector.....	70
3.4.2 ASU II ONS Parameters.....	72
3.4.3 ASU and Universal ASU ONS Parameters.....	72
3.4.4 ASU II LS Trunk Parameters.....	74
3.4.5 LS Trunks Selection in the UK.....	75
3.4.6 LS Trunks, Acceptable Noise Levels.....	75

4 Specifications..... 79

4.1 Services Units.....	80
4.2 Dimensions.....	81
4.2.1 Services Units.....	82
4.3 Power.....	83
4.3.1 Analog Services Units (ASU).....	84
4.4 Telephone Power.....	84
4.4.1 CXi II Power over Ethernet (PoE).....	85
4.4.2 3300 Power Dongle (Cisco compliant).....	85
4.4.3 HP ProCurve Products.....	86
4.5 Hardware Interface Comparison of EX Controller with other 3300 ICP Controllers and SMB Controller.....	88

5 Appendix A : Signaling, Tones, and Transmission..... 92

5.1 Time-Out Information.....	92
5.2 Transmission Characteristics.....	94
5.2.1 Compliances.....	94
5.2.2 Line and Trunk Support Characteristics (North America).....	94
5.3 Loss Plan Matrices.....	95
5.3.1 Port Abbreviations.....	95
5.4 Tone Plans.....	113
5.4.1 Australia.....	113
5.4.2 Brazil.....	115
5.4.3 China.....	117
5.4.4 France.....	118
5.4.5 Germany.....	120
5.4.6 Italy.....	122
5.4.7 Latin America.....	124
5.4.8 The Netherlands.....	125
5.4.9 New Zealand.....	127
5.4.10 North America.....	129
5.4.11 Portugal.....	131
5.4.12 Spain.....	132
5.4.13 United Kingdom.....	134

6 Appendix B : Ethernet Cabling Guidelines..... 137

6.1 Maximum Cable Lengths.....	137
6.2 Cabling Guidelines for the Desktop.....	138
6.3 Cabling Guidelines in the Equipment Room.....	141

6.4 Category 3 Cabling Guidelines (CXi II)..... 149

Introduction

This chapter contains the following sections:

- [Important Safety Instructions](#)
- [New Hardware](#)

About this Guide

The Hardware Technical Reference Manual provides technical information for Mitel® 3300 IP Communications Platform (ICP) hardware and supported peripherals. It covers hardware descriptions, specifications, and signaling parameters. This manual is intended for use by qualified technicians and system engineers planning an installation of the 3300 ICP system.

Note:

- For information on EX Controller, see the *EX Controller Installation and Administration Guide*.
- For information on SMB Controller, see the *MiVoice Business System Manual for Mitel SMB Controller* document.

What's New in this Document

This section describes the changes in this document due to new and changed functionality in MiVoice Business Release 10.5.

Table 1: Document Version 1.0

Feature/Enhancement	Document Update	Location	Publishing Date
NA	No new changes has been made for this Release 10.5.	NA	October 2025

1.1 Important Safety Instructions

Warning:

Before attempting installation, read the 3300 ICP Safety Instructions available on the Mitel Customer Documentation web site.

 **Warning:**

Failure to follow all instructions may result in improper equipment operation and/or risk of electrical shock.

3300 ICP Overview

The Mitel 3300 ICP is a converged Voice over IP (VoIP) solution that manages calls from IP devices connected to an IP network and from TDM (time division multiplexing) devices on existing telephony networks. The 3300 ICP controller provides IP and TDM call processing. The 3300 ICP system may also include Analog Services Units and peripheral cabinets to provide connectivity for analog and digital trunks and telephones.

1.2 New Hardware

Mitel MiVoice Business Release 9.1

The AX controller now requires a single 16 GB Compact Flash (CF) for the system software, database, and embedded voice mail, instead of the 2 GB/4 GB CF combo in pre-9.0 release. See [Standard Configuration for AX](#) on page 6.

MXe III-L Controller

The MXe III-L (L = LAN) controller was developed because some hardware parts of the MXe III controller will no longer be available.

The MXe III-L controller supports MiVoice Business 9.1 and later only. The MXe III-L controller will be available in Q1, 2020 only for the following regions: North America, UK, Middle East, Africa, Australia, and New Zealand.

The MXe III-L controller uses the same RTC/E2T compute cards and MMC cards that the MXe III supports with MiVoice Business 9.1; the performance of the MXe III-L controller is the same as the MXe III controller.

The MXe III-L controller is different from the MXe III controller in the following ways:

- No WAN support
- No LAN Port 2 support
- No L2 redundancy
- No IGMP filtering
- No 1G Ethernet speed for LAN port

If you have to replace your MXe III controller with an MXe III-L controller, follow the instructions in **KMS article S05142**.

1.2.1 Supporting Documentation

Refer to Mitel OnLine for Customer Documentation and Knowledge Base Articles.

This chapter contains the following sections:

- [Controller Types](#)
- [AX Controller](#)
- [MXe Controller](#)
- [CX II and CXi II Controllers](#)
- [Connections](#)
- [Field Upgradeable and Replaceable Controller Modules \(AX, MXe, CX\(i\) II\)](#)

Description

The 3300 ICP Controller contains the logic, processor, memory, communication interfaces, and call control software for managing call processing on the system.

Note:

Refer to the 3300 ICP Release 8.0 version of the Hardware Technical Reference Manual for details on: MXe, MXe II, CX and CXi controllers.

Note:

Refer to the 3300 ICP Release 7.0 version of the Hardware Technical Reference Manual for details on the older controllers; 100-user, 250/700-user, LX and MX.

2.1 Controller Types

- [AX Controller](#) on page 4
- [MXe Controller](#)
- [CX II and CXi II Controllers](#)

The Controller consists of the following main components:

- Real Time Complex (RTC): stores Call Control software and provides main control
- Ethernet to TDM (E2T): converts Time Division Multiplex voice streams to IP packets.
- Mid-plane: a circuit board that holds functional circuit blocks such as Ethernet devices and LEDs
- Echo Cancellor: provides echo cancellation on IP calls.
- Quad Digital Signal Processor (DSP): provides telecom functions and G.279 compression
- Hard Disk (CXi II/MXe) : stores database, configuration data, and embedded voicemail.
- Compact Flash (AX) : stores database, configuration data.
- System i-Button: contains a unique serial number that identifies the controller for licensing purposes.

- Firewall (CXi/MXe excluding MXe III-L): secures the WAN port against unauthorized access by dropping or rejecting unknown packets, allowing or disallowing IPSec and PPTP pass-through, and performing many-to-1NAT (IP masquerading)

The WAN port and firewall in the CXi and MXe (excluding MXe III-L) is intended to be used either as an access point for performing remote diagnostics and maintenance (similar to a MODEM) or, if the Firewall function is disabled, as internal router to transparently route packets between the WAN port and the controller's LAN ports.

Note:

The WAN port and internal firewall should only be used as a network router in situations where the amount of internet access is very low. For most installations, the Administrator should employ a dedicated internet router/firewall.

- Stratum 3 Clock: provides synchronization for digital connections to external networks.
- Power supply: supplies power to the controller

2.1.1 Optional Components

The following modules can be installed to increase capacity, expand functionality or improve reliability (see Field Upgradable and Replaceable Controller Modules):

- Quad Digital Signal Processor (DSP) Mitel Mezzanine Card (MMC)
- DSP II MMC
- Echo Canceller Module
- Quad CIM (Copper Interface Module) MMC
- 4 + 12 port combo card and 24 port ONS card (AX)
- Dual T1/E1 Framer MMC
- T1/E1 Combo Card
- Quad BRI Framer MMC
- Analog Main Board (AMB)/Analog Option Board (AOB) (CX(i) II controllers only)
- RAID controller and additional hard drive
- Redundant power supply

2.2 AX Controller

The AX controller is ideal where a high density of analog devices is required. There are two typical system configurations, standalone and networked, although as with any system, these functions may be mixed.

- The AX supports up to 48 T1 or 60 E1 on-board digital trunks, up to 112 IP phones, and 288 analog phones (maximum 400 devices).
- The AX controller will support a second AC Power Supply Unit.

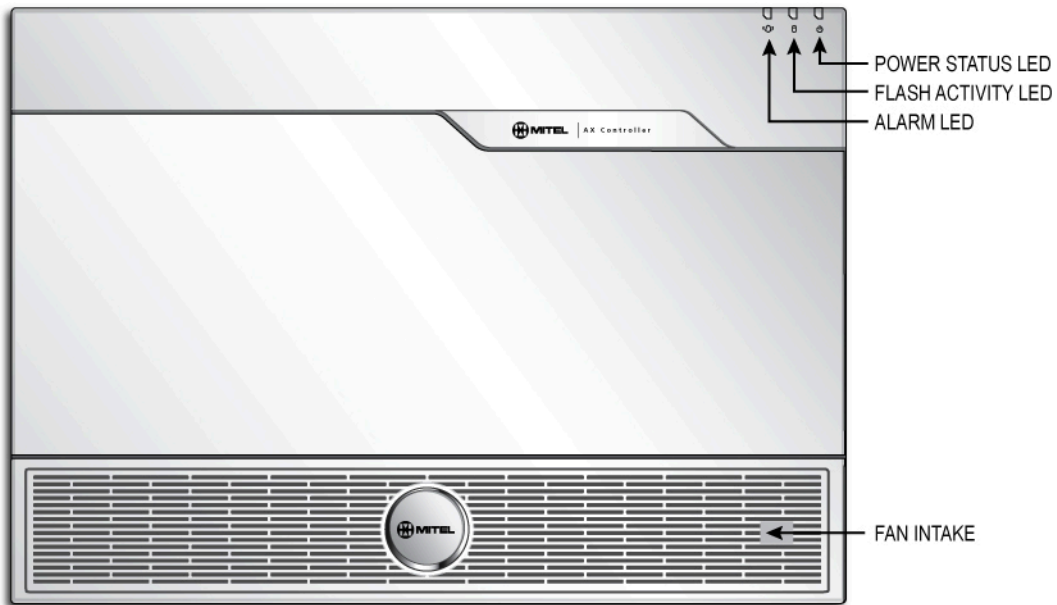

IP0966

Figure 1: AX Controller

The controller front panel consists of the following components:

- System LEDs - Alarm, Flash Activity, Power/Status

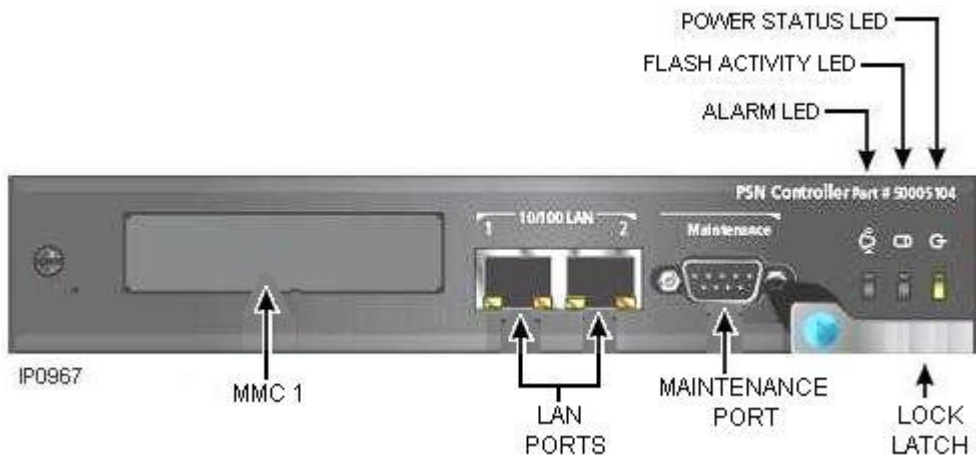

Figure 2: AX Controller Front View (Cover Removed)

The controller card in the AX controller rear panel consists of the following components:

- One slot for expansion modules
- Two 10/100 BaseT Ethernet LAN ports (RJ-45 connector)
- One DB-9 maintenance port
- System LEDs - Alarm, Flash Activity, Power/Status



Figure 3: AX Controller Rear View

The controller rear panel consists of the following components:

- One or two power supply units
- Fan complex
- Controller card (described above)
- 12 line card slots
- Protective ground

2.2.1 Standard Configuration for AX

- One 450 MHz processor for combined RTC and E2T functionality
- 4 embedded DSP resources
- 16 GB flash card for system software, database, and embedded voice mail
- 512 MB of RAM

2.2.2 Optional Configuration

You can add:

- 24 port ONS line card (up to 12)
- 16 port ONS line card (up to 12)
- 4 + 12 port combo card (up to 12)
- Quad DSP MMC or octal DSP II MMC
- Dual T1/E1 MMC
- T1/E1 Combo MMC
- Dual FIM
- Quad BRI MMC
- 128 channel Echo Canceller

- Second AC Power Supply for redundant power

2.3 Mx e Controller

- The MX Expandable controller supports 300 to 1400 (expanded version) users and 350 to 1500 devices.
- The Mx e controller ships with one 533 MHz RTC processor and embedded DSP resources (equivalent to three Quad DSP modules), a hard drive, and an Analog Main Board (AMB).
- The Mx e controller can be upgraded with the addition of a second processor, E2T, to increase capacity.
- Redundancy is available with the addition of a RAID controller, a second hard disk, and a second AC PSU.

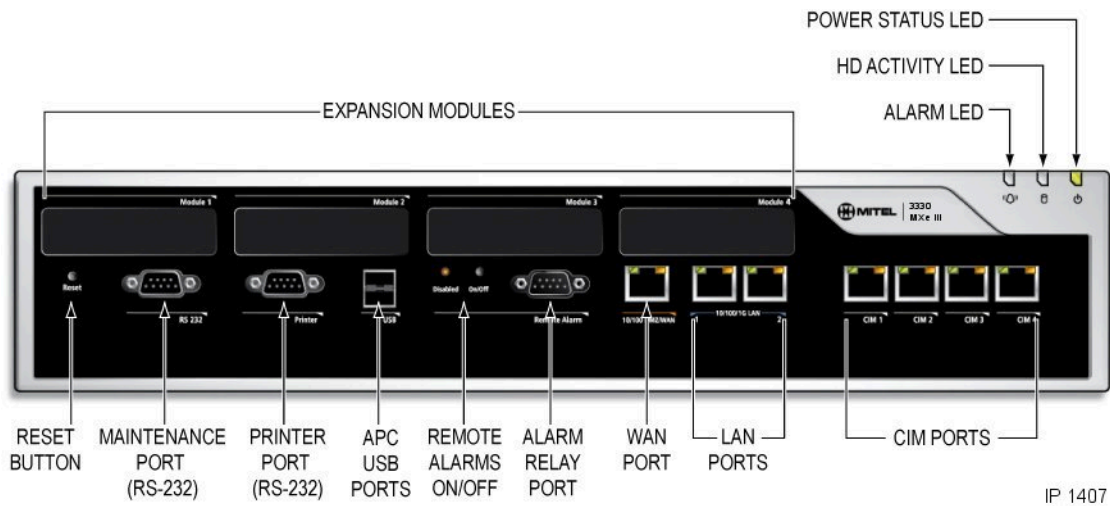

Figure 4: Mx e Controller Front View



Figure 5: Mx e III-L Controller Front View

The controller front panel consists of the following components:

- Six slots for expansion modules (two internal)
- Alarm port
- Two DB-9 ports, both connected to the RTC, for maintenance and printer connection

- Two 10/100/1G BaseT Ethernet LAN ports (RJ-45 connector)

Note:

1G BaseT Ethernet LAN Ports are not supported on Mx e III-L controllers.

- One 10/100 BaseT Ethernet WAN port (RJ-45 connector) with built-in firewall

The WAN port and firewall is intended to be used either as an access point for performing remote diagnostics and maintenance (similar to a MODEM) or, if the Firewall function is disabled, as internal router to transparently route packets between the WAN port and the controller's LAN ports.

Note:

The WAN port is not supported on Mx e III-L controllers.

Note:

The WAN port and internal firewall should only be used as a network router in situations where the amount of internet access is very low. For most installations, the Administrator should employ a dedicated internet router/firewall.

- Four CIM ports
- Remote alarms on/off
- System LEDs - Alarm, Hard Drive, Power/Status
- Status LEDs - Ethernet, CIM, and Alarm
- Reset button.

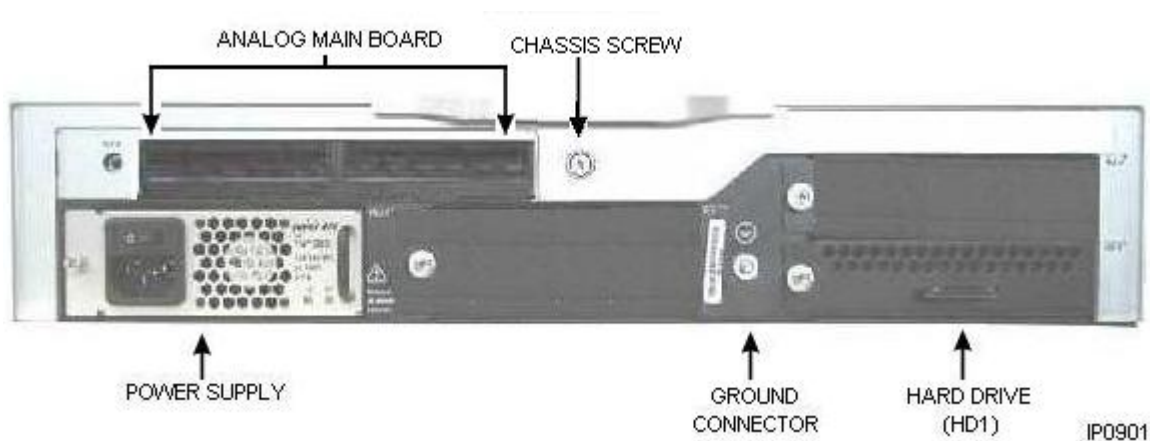

Figure 6: Mx e Controller Rear View

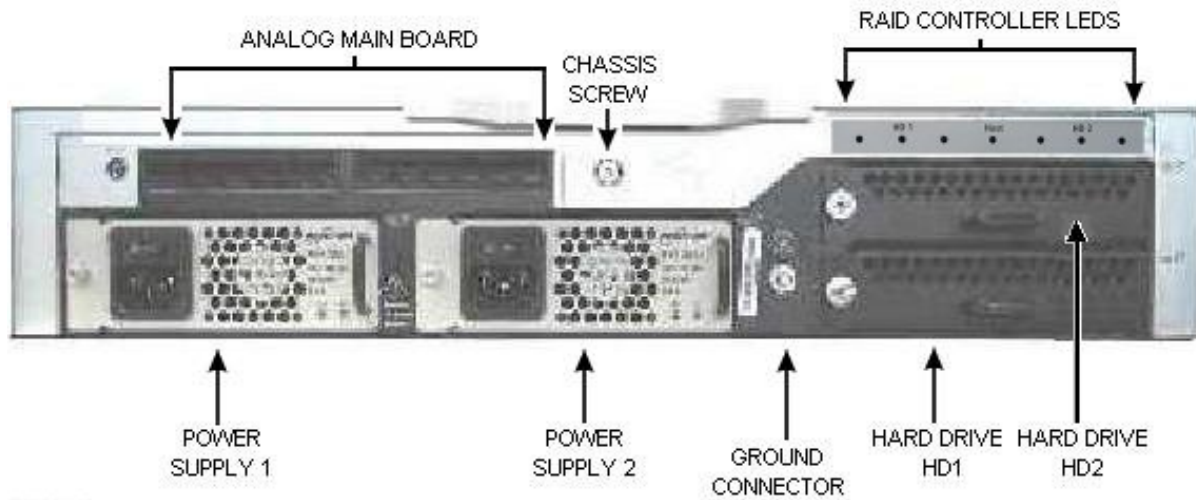

Figure 7: MXe Controller with Redundant Hard Drive and Power Supply - Rear View

The rear panel has an input power connector (standard male IEC320 AC) and protective ground.

2.3.1 Standard Configuration for MXe

- Six slots for expansion modules
- RTC / E2T compute card:
 - On MXe III (Release MCD 9.0 and later): MPC8360 533 MHz processor with 1G of DDR
 - On MXe III-L: MPC8360 533 MHz processor with 1GB of DDR
- Mid-plane with 4 21363 DSP and DSP Echo Canceller module included (3300 ICP S/W Rel. 8.0 and later).
- Stratum 3 clock
- Analog Main Board for embedded analog trunks and lines
- Two (redundant) cooling fans

2.3.2 Optional Configuration

You can add

- E2T Processor Card (MMC-C) with 1 GB RAM (for MXe III and MXe III-L)
- 1 GB RAM Module Upgrade (for MXe III only)
- One or two 128-channel Echo Canceller modules
- DSP or DSP II modules for G.729a compression
- DSP II modules for FAX Relay (T.38)
- Up to four Dual FIMs for connecting peripheral cabinets, and DSUs (not applicable for MXe III-L controllers)
- Up to four Dual T1/E1 Framers modules
- Up to four T1/E1 Combo modules
- Up to three Quad BRI Framers modules
- Quad CIM

- RAID (Redundant Array of Independent Disks) module
- Second AC Power Supply for Redundant Power

2.4 CX II and CXi II Controllers

Note: CXi II controllers are no longer available for purchase.

The CX(i) II controllers are next-generation versions of the original CX and CXi controllers. Featuring increased processing power, the CXi II can support up to 150 users and with fewer limitations on resource (DSP) intensive applications. In fact, the base configuration of the CXiII has all the DSP resources the system requires. You only need to add more DSP resources for enhanced functionality—for example, T.38 fax support—not performance scaling. For more information on resource-related improvements to the CXi II, see the “Engineering Guideline Updates” on page 14. Other key enhancements of and CXiII include:

- two 21363 DSPs on the main board providing sufficient resources to support main telephony functions (tone generation, tone detection, voice mail, record a call, 30-party conference) and 32 channels of Echo cancellation.
- redundant fans

The CX(i) II controller front panel consists of the following components:

- Three slots for expansion modules
- DB-9 RS-232 Maintenance Console Port used to access the operating system shell. Also supports hardware flow control for an external modem. All other directed I/O function such as the virtual printer port and embedded CPU serial port are accessed through either secure telnet or a TCP/IP socket.
- CXi II only; 10/100 BaseT WAN port (RJ-45 connector) with built-in firewall

The WAN port and firewall is intended to be used either as an access point for performing remote diagnostics and maintenance (similar to a MODEM) or, if the Firewall function is disabled, as internal router to transparently route packets between the WAN port and the controller's LAN ports.

Note:

The WAN port and internal firewall should only be used as a network router in situations where the amount of internet access is very low. For most installations, the Administrator should employ a dedicated internet router/firewall.

- CXi II only; 10/100/1000 BaseT LAN port (RJ-45 connector)
- CXi II only; 16 10/100 BaseT 802.3af LAN ports connected to an internal Ethernet Layer 2 switch.

- Reset button

Note:

The Reset button, resets the Ethernet/POE module and the main processor.

- Status LEDs - Power, media access, and alarm

2.4.1 10/100 802.3af LAN Ports (CXi II)

The CXi II includes a 16-port managed Layer 2 Ethernet switch. Each port supports auto-negotiation and is able to connect to 10Base-T or 100Base-TX devices and determine the appropriate data rate from information provided to it. Duplex mode and flow control are also programmable for each port. The ports use 8-way RJ-45 connectors that conform to Category 5 wiring standards. Although CAT5 cabling is recommended, Category 3 can be used for limited installations. Refer to Appendix A and the Engineering Guidelines for CAT3 Cabling details.

The 16 ports comply with the 802.3af Power over Ethernet specification, which enables them to deliver power to IP phones and other Ethernet devices over Category 3 or 5 cabling. As a minimum, the PoE module provides enough power for 16 IP phones, some of which may be fitted with PKMs. For details about PoE and planning a PoE installation, see the Engineering Guidelines on the Mitel Edocs web site (<http://edocs.mitel.com>).

The internal switch uses 802.1p/Q VLAN prioritization to ensure the quality of voice calls, forwarding packets with priority value 6 (from IP phones) ahead of packets with priority value 0 (from PCs and other IP devices). Programming is required only if an expansion switch is connected. Refer to the CXi II Specific Guidelines in the Engineering Guidelines document.

2.4.2 Front View - CX(i) I I Controllers

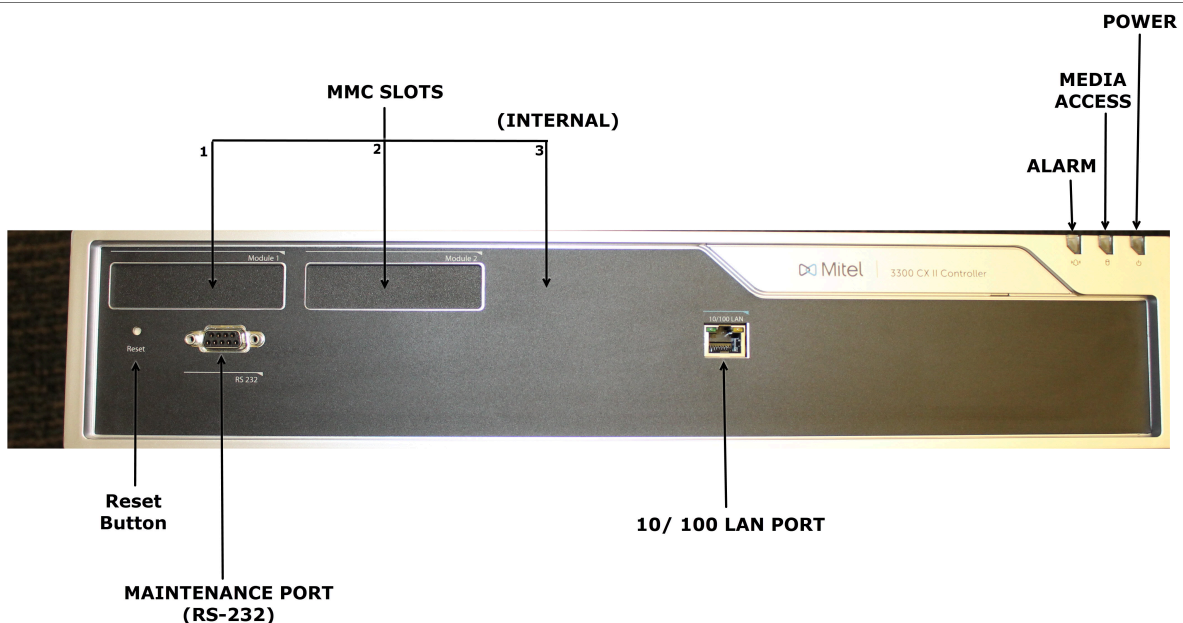

Figure 8: Front View - CX II Controller

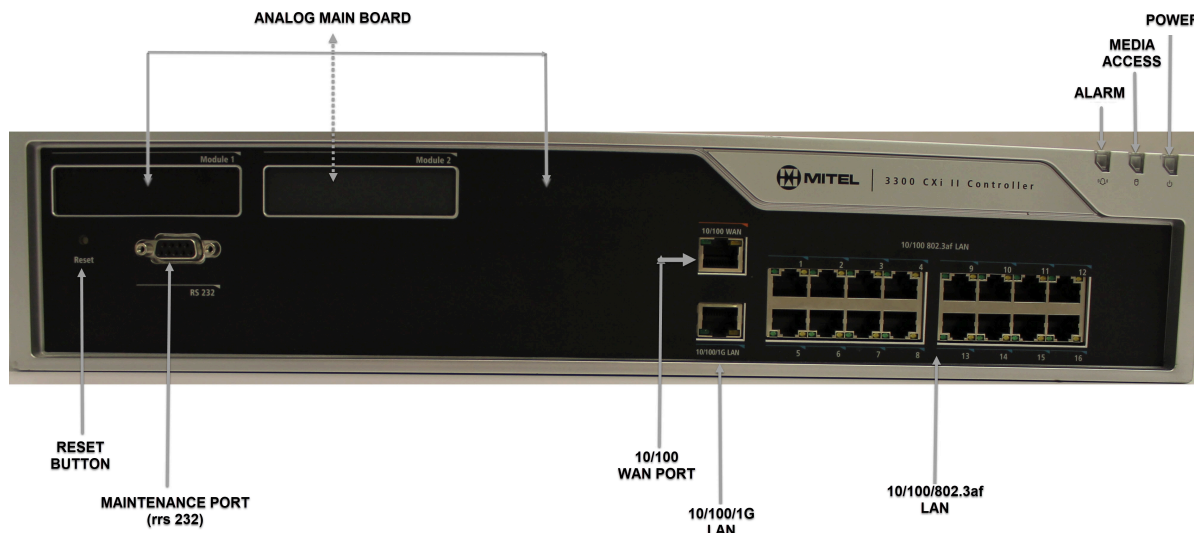

Figure 9: Front View - CXi II Controller

2.4.3 Rear View - CX(i) II Controllers

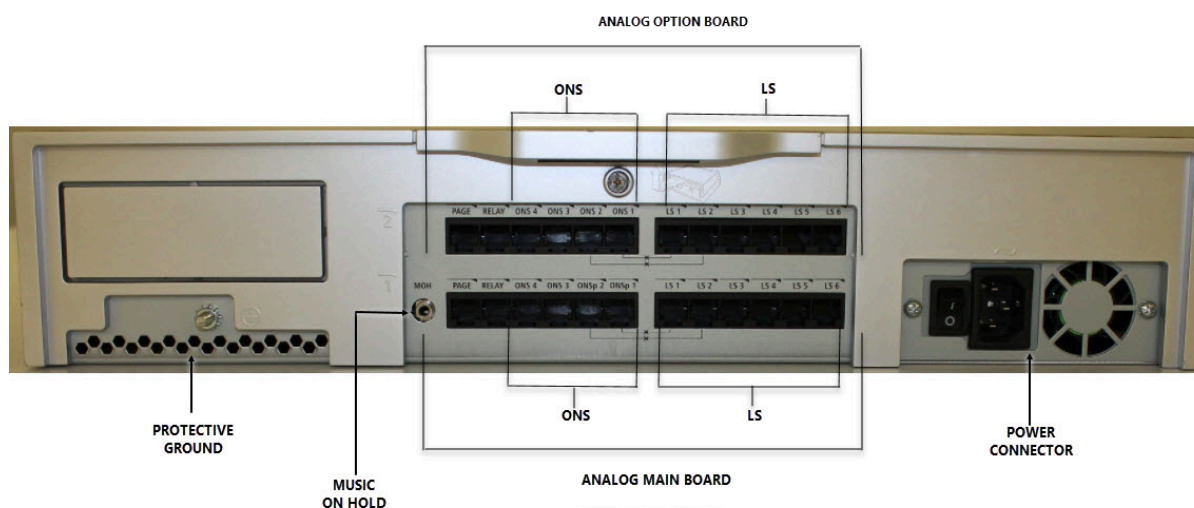

Figure 10: Rear View - CX (i) II Controller

The controller rear panel consists of the following components:

- Input power connector and switch
- Protective ground
- Analog Main Board (AMB). Includes six LS trunk ports with CLASS support (CLASS is available in North America and Latin American only), four ONS ports, a single Music-on-Hold port (one source supported), a single Paging port (one paging zone), and two System Fail Transfer circuits.
- Analog Option Board (optional). Includes six LS trunks ports with CLASS support, four ONS ports, one System Fail Transfer circuits and one paging circuit.

2.4.4 Standard Configuration for CX(i) II

- One 400 MHz MPC8360E processor
- 1 GB of RAM
- Analog Main Board (AMB) for analog trunks and lines
- Embedded L2-PoE Ethernet switch with 16 ports (CXi II only)
- Stratum 3 clock
- Two 21363 DSPs on main board

Mass storage (spinning hard disk drive or solid state drive) is provided in a separately orderable kit. The kit includes factory-installed Mitel MiVoice Business software.

The standard configuration does not support compression. Compression channels can be added using the DSP-II card. The DSP II module provides up to 64 G.729 voice compression channels. This module is also required for T.38 FAX. The DSP II module DOES NOT PROVIDE additional telephone resources (tone detectors and receivers, voice mail, or conference).

2.4.5 Optional Configuration

You can add

- DSP II module for G.729 voice compression and FAX Relay (T.38)
- One or two T1/E1 Combo cards for digital trunking
- One or two Quad BRI Framer modules
- Analog Option Board (AOB)
- Quad CIM.

Dual or Quad DSP modules are supported but not required as the embedded 21363 DSPs provide sufficient telephony resources .

2.5 Connections

Controller Interface

Table 2: Controller Interfaces

Connector Function	Type	Quantity			Signals	Comments
		CX II/ CXi II	MXe III/ MXe III-L	AX		
RS-232 (front panel)	DB-9	1	2	1	Txd, Rxd, (RTS), (CTS), (DTR), (CD), DSR, Gnd (parenthesis indicates operational function, dependent upon application)	DCE pinout, female. 115Kb/s data rate. Default setting: 9600 bits/s 8 data bits No parity bit 1 Stop-bit Txd, Rxd, Gnd See Note 1.
SATA	7-pin male	1	1	N/A	Internal Hard Disk Drive or Solid State Drive.	Internal to controller. Used to connect system hard disk drive or solid state drive.
10/100 BaseT Ethernet	8-pin Mod-jack	1/17	1/2	2	TxP, TxN, RxP, RxN - (Crossover DX connections)	User side pinout. See Note 3
10/100/1000 BaseT Ethernet	8-pin Mod-jack	0/1	2/0	0 0	TxP, TxN, RxP, RxN - (Crossover DX connections)	User side pinout

2.5.1 RS-232 Ports (Printer and Maintenance)

The two RS-232 ports require male DB-9 connectors. The following table lists the pin signals.

Table 3: RS-232 Asynchronous Serial Port Pin Allocation

Pin Number	Signal Name	Abbreviation
1	Data Carrier Detect	DCD
2	Receive Data	RXD
3	Transmit Data	TXD
4	Data Terminal Ready	DTR
5	Ground	GND
6	Data Set Ready	DSR
7	Request to Send	RTS
8	Clear to Send	CTS
9	n/a	n/c

2.5.2 Copper Interface (Embedded and MMC) Ports

The CIM ports require 8-pin modular jacks (RJ-45) consisting of 2 balanced signal pairs on a CAT5 Unshielded Twisted Pair (UTP) crossover cable. The pairs are arranged: 1,2: 3,6; 4,5; 7,8.

Table 4: CIM Connector Pin Allocations

Pin Number	Signal	Pin Number	Signal
1	RX+	5	–
1			
2	RX-	6	TX-
3	TX+	7	–

Pin Number	Signal	Pin Number	Signal
4	–	8	–

2.5.3 Ethernet ports

The Ethernet ports are IEEE 802.3 supporting 10BaseT and 100BaseT (AX and MXe III-L controllers; full and half-duplex) and, for the CXi II, MXe and MXe Server, 10BaseT, 100BaseT, and 1000BaseT. The connection requires a CAT5 cable with an RJ-45 connector.

Table 5: 10/100 Ethernet Port Pin Allocation (all controllers)

Pin Number	Signal	Pin Number	Signal
1	RX+	5	–
2	RX -	6	TX -
3	TX+	7	–
4	–	8	–

Table 6: 10/100/1000 Ethernet Port Pin Allocation

Pin Number	Signal 10/100 Mode	Signal 1000 Mode	Pin Number	Signal 10/100 Mode	Signal 1000 Mode
1	TX+	TRD0+	5	–	TRD2-
2	TX-	TRD0-	6	RX-	TRD1-
3	RX+	TRD1+	7	–	TRD3+
4	–	TRD2+	8	–	TRD3-

2.5.4 Alarm Port

The Alarm port requires a male DB-9 connector. The following table lists the signal for each pin.

Table 7: Alarm Port Pin Allocation

Pin Number	Signal
1	Critical Alarm (See Note 2)
2	Critical Alarm Return (See Note 2)
3	–
4	Major Alarm
5	Major Alarm Return
6	–
7	Minor Alarm
8	Minor Alarm Return
9	–

Note:

Contact closed when alarm is present.

Note:

Loss of power to the controller trips (closes) the Critical Alarm relay on the alarm port. The alarm port is not available on the AX and CXi II.

2.6 Field Upgradeable and Replaceable Controller Modules (AX, Mx, CX(i) II)

Modules are field replaceable units (FRUs) that expand the functionality and capacity of the controllers. Communication interface modules—T1/E1 Framer, T1/E1 Combo Card, Quad BRI Framer, and Quad CIM—are installed in the slots with external access.

Two analog boards are available for the CXi II, and one for the Mx. The CXi II and Mx use the same analog main board. The analog boards provide embedded analog capability on the controller.

CAUTION:

These modules are not designed for hot insertion into a powered-up controller card. Refer to the 3300 ICP Technician's Handbook for installation procedures.

This section covers the following modules and boards. [Table 8: Support for FRU modules by controller](#) shows which modules and boards are supported on each controller.

- [Stratum 3 Clock Module](#)
- [Mx Processor \(E2T/RTC\)](#)
- [Digital Signal Processor Modules](#)
- [Echo Canceller Module](#)
- [Quad Copper Interface Module](#)
- [T1/E1 Combo Card](#)
- [Quad Basic Rate Interface Framer Module](#)
- [Analog Boards](#) on page 33
- [AX and ASU II Specific Modules](#) on page 29

Table 8: Support for FRU modules by controller

	Mx	CXi II	AX
Stratum 3 clock	√		√
Mx processor (E2T/RTC)	√ (single processor)		
RAID Controller	√		
Dual DSP		√	

	MXe	CXi II	AX
Quad DSP	√		√
DSP II	√	√	√
Echo Canceller	√		√
Quad CIM	√	√	
Dual T1/E1	√		√
T1/E1 Combo	√	√	√
Quad BRI	√	√	√
4 + 12 Port Combo			√
24 Port ONS card			√
16 Port ONS card			√
AOB		√	
AMB	√	√	

2.6.1 Stratum 3 Clock Module

Description

The Stratum 3 clock module is designed specifically for high performance use in telephony equipment. The Stratum 3 clock provides synchronization for digital connections to external networks. It helps ensure system reliability by monitoring its references for frequency accuracy and stability and by maintaining tight phase alignment between redundant primary and secondary system clocks even in the presence of high network jitter.

All of Mitel's controllers use the Stratum 3 clock module.

The Stratum 3 clock on the CXi II is embedded on the main board and not field replaceable.

2.6.2 Mx Processor (E2T/RTC)

The MMC-C processor runs the Real Time Complex (RTC), the Ethernet to TDM (E2T) function or, in some controllers, both. The E2T converts voice streaming between TDM and IP. The RTC runs the call control for the controller and acts as a gateway for the IP.

2.6.3 Digital Signal Processor Modules

The Digital Signal Processor (DSP) modules contain DSPs that perform the following functions:

- Conferencing
- Voice Mail playback and recording
- Call Progression tone generation and detection
- Auto-attendant support
- G.729a compression (for IP trunking and wireless phones)
- FAX Relay (T.38)

Refer to the Technician's Handbook and Engineering Guidelines for DSP configuration rules.

2.6.3.1 Quad DSP MMC

The Quad DSP has four DSPs and can provide 32 bi-directional channels of G729a compression (eight for each DSP). The Quad DSP module does not support FAX Relay (T.38).

2.6.3.2 DSP II MMC

The DSP II MMC is a high-density DSP resources card and has eight DSPs. Each DSP supports eight channels of FAX Relay (T.38) or 16 channels of G.729a compression.

2.6.4 Echo Canceller Module

The Echo Canceller (EC) module provides echo cancellation on Ethernet to TDM (E2T) channels. Each bi-directional E2T channel requires one bi-directional EC channel. The EC module is available in 64-channel and 128-channel versions.

The 100-user controllers have embedded echo cancellers and do not require EC modules. The Mx Server ships with two 128-channel echo cancellers. The 250-user controller is shipped with one 64-channel EC module that will handle the full capacity of the system. The 700-user controllers require 128 channels of echo cancellation from either two 64-channel modules (if upgraded from 250 to 700-users) or one 128-channel module.

The AX controller uses DSP echo cancellers (40 channels in number) in its default configuration, but can use the 128-channel module to increase capacity (hardware echo cancellers replace the DSP echo cancellers). When the 128-channel module is installed, the echo canceller channels on the embedded DSPs revert to telecom resource use.

The CXi II controllers do not use the echo canceller modules.

2.6.5 Quad Copper Interface Module (CIM)

Description

The 3300 ICP controller, with 3300 Release 7.1 or later software, supports the Quad CIM MMC for connection to an Analog Services Unit, Universal ASU, or ASU II. One or two (only one on the CXi II) Quad CIMs can be installed in any 3300 ICP controller (except on the AX and MXe Server) to provide for connection to a maximum of 12 ASUs, with the exception of the CXi II controllers, which will support only the first 3 ports of the Quad CIM module.

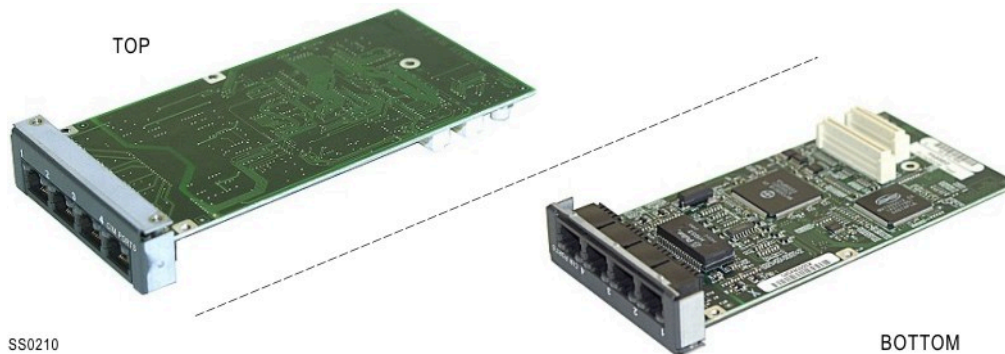

Figure 11: Quad Copper Interface Module (CIM)

2.6.5.1 Specifications

The CIM ports require standard 8-pin modular jacks (RJ-45) consisting of 2 balanced signal pairs on Category 5 Unshielded Twisted Pair (UTP) crossover cable.

The CIM supports a distance of up to 100 feet or 30 meters between cabinets.

2.6.6 Dual T1/E1 Framer

Description

The Dual T1/E1 Framer MMC is a digital trunk interface that supports the direct connection of ISDN-PRI, T1/D4, QSIG, and MSDN/DPNSS trunks to the controller.

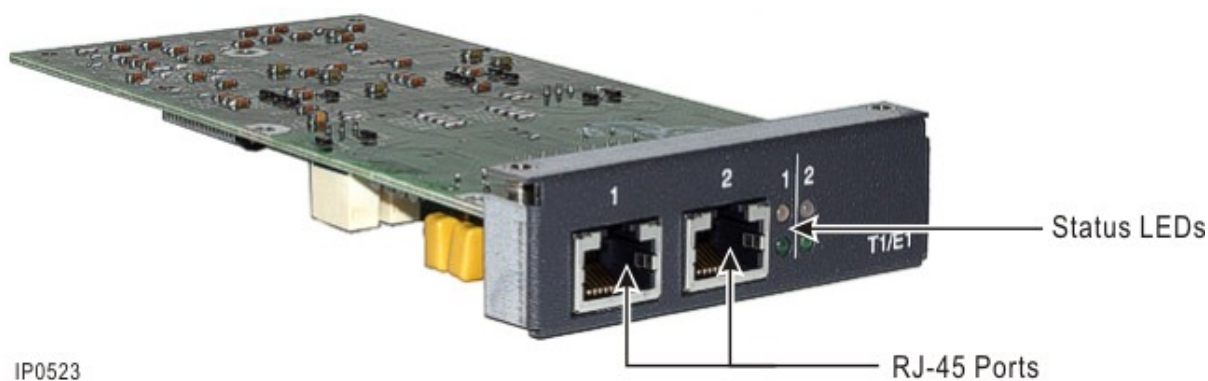

Figure 12: Dual T1/E1 Framer

This module has two ports, each supporting a digital link. LEDs on the faceplate indicate the status of each link. For a description of LED status and alarm indications, refer to the *3300 ICP Technician's Handbook*.

Each of these links can be configured as a T1 (1.544 Mbps) (North America) or E1 (2.048 Mbps) (Europe) interface.

T1 features:

- Support for ISDN PRI, QSIG, and T1/D4 links
- B8ZS or AMI line coding
- Superframe (SF) or Extended Superframe (EXF) framing

E1 features:

- Support for ISDN PRI and QSIG links
- CRC4 enable or disable

Note:

The following ISDN PRI features are not supported: D-channel backup, NFAS, min/max capability, and TDM XNET (Hybrid XNET is supported).

The Dual T1/E1 Framer MMC is a Field Replaceable Unit (FRU) that can be installed in any of the MMC sites in the front panel of the 3300 controller.

Note:

The module is not designed for hot insertion into an MMC module site on a powered-up carrier card. Refer to the *3300 ICP Technician's Handbook* for installation procedures.

2.6.6.1 Specifications

Table 9: T1/E1 Framer Supported Protocols and Variants

Interface	Trunk	Protocol	Variant	
T1	ISDN Primary Rate Interface (PRI)	DMS 100	n/a	
		DMS 250	n/a	
		NI-2	BellCore National ISDN	
			5ESS	
			GTD5	
		4ESS	n/a	
		IDA-P		
		XNET	Hybrid	
		QSIG	QSIG	ISO
		T1/D4	Digital CO	n/a
			Digital DID	n/a
			Digital E&M	n/a
		MSDN/DPNSS	MSDN/DPNSS	n/a
E1	ISDN Primary Rate Interface (PRI)	Euro ISDN	Euro-Standard	
			Euro-Numeris	

Interface	Trunk	Protocol	Variant
			Euro-Cayman
			Telecom Italia
		XNET	Hybrid
	QSIG	QSIG	ISO
			ETSI
	MSDN/DPNSS	MSDN/DPNSS	n/a

Table 10: Dual T1/E1 Framer and T1/E1 Combo Specifications

	T1 Links	E1 Links
Channels	23 B channels and 1 D channel per ISDN PRI or QSIG link 24 B channels per T1/D4 link	30 B channels and 1 D channel per ISDN PRI or QSIG link
Maximum Line Length (see Note below)	200 m (655 ft.)	200 m (655 ft.)
Line Impedance	100 ohms	75 or 120 ohms

Note:

The primary and secondary controllers must be located within 10 meters of each other. The cable that connects the resilient link port in the T1/E1 Combo MMC on the primary controller to the redundant port in the T1/E1 MMC on the secondary controller must not exceed 10 meters in length.

2.6.6.2 Pin Allocations

Table 11: Dual T1/E1 Framer Pin Allocations

Pin Number	Signal	
	Network Termination (Default)	Line Termination
1	Rx Ring	Tx Ring
2	Rx Tip	Tx Tip
3	–	–
4	Tx Ring	Rx Ring
5	Tx Tip	Rx Tip
6	–	–
7	–	–
8	–	–

Note:

Network and Line Termination settings are software-controlled.

2.6.7 T1/E1 Combo Card

Description

The T1/E1 Combo MMC combines trunking and DSP functionality on a single card. The T1/E1 Combo card provides for resiliency. To use resiliency, you must have two 3300 ICPs running 3300 Release 7.0 software (or later) and a T1/E1 trunk connected to both ICPs. The trunk can fail over to the secondary ICP in the event of a primary ICP failure.

The digital trunk port can be configured as a T1 interface (1.544 Mbps) that provides 24 B-channels for T1/D4 and 23 B-channels for ISDN PRI or QSIG. The DSP provides resources for CLASS tone generation, Record-a-Call conferences, DMTF receivers, and voice echo cancellation.

Compression and T.38 services are provided by the DSP-II MMC card. No compression is licensed on the dual or quad 21161 DSP-I MMCs.

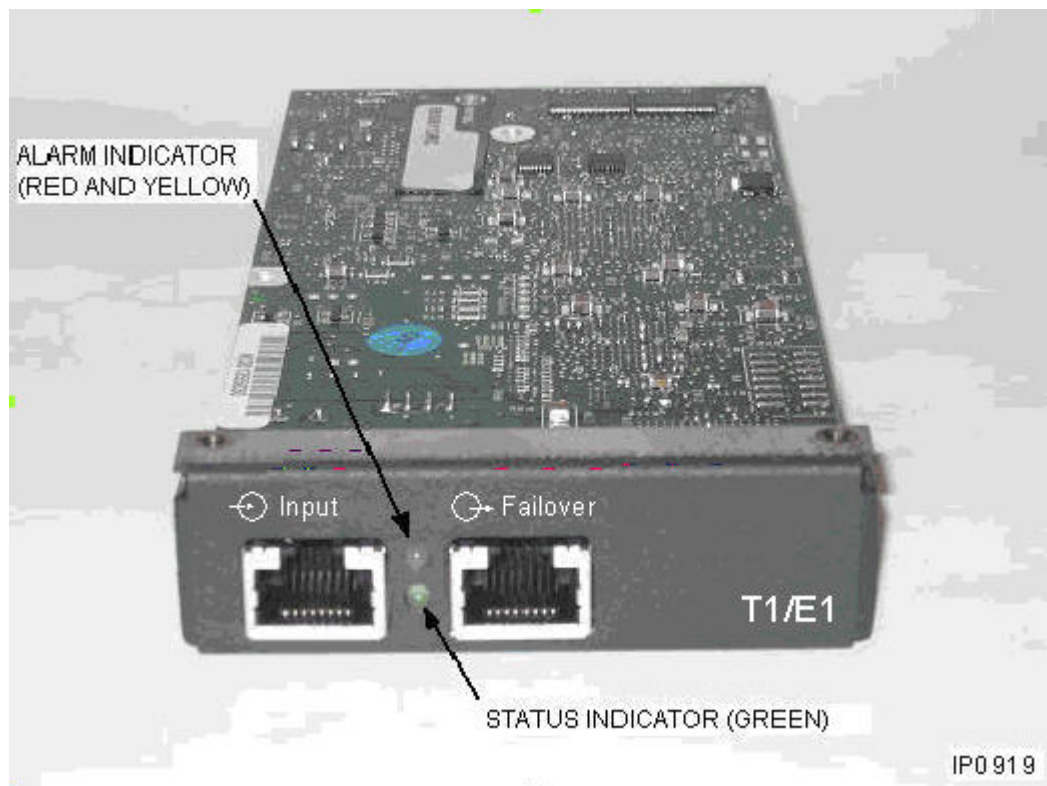

Figure 13: T1/E1 Combo Card

2.6.7.1 Specifications

Refer to [Table 9: T1/E1 Framer Supported Protocols and Variants](#) on page 23 and [Dual T1/E1 Framer and T1/E1 Combo Specifications](#).

2.6.7.2 Pin Allocations

Table 12: T1/E1 Combo Card Pin Allocations

Pin Number	Signal	
	Network Termination (Default)	Line Termination
1	Rx Ring	Tx Ring

Pin Number	Signal	
	Network Termination (Default)	Line Termination
2	Rx Tip	Tx Tip
3	–	–
4	Tx Ring	Rx Ring
5	Tx Tip	Rx Tip
6	–	–
7	–	–
8	–	–

Note:

Network and Line Termination settings are software-controlled.

2.6.8 Quad Basic Rate Interface (BRI) Framer

Description

The Quad Basic Rate Interface (BRI) Framer MMC is a digital trunk interface that supports the direct connection of BRI trunks to the controller. The Quad BRI Framer is not supported in North America.

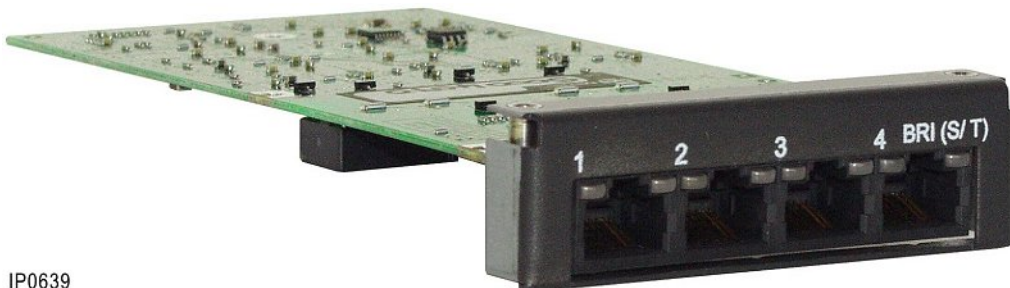

IP0639

Figure 14: Quad Basic Rate Interface (BRI) Framer

The Quad BRI Framer MMC has four ports, each supporting a digital link. LEDs on the faceplate indicate the status of each link. For a description of LED status and alarm indications, refer to the *3300 ICP Technician's Handbook*.

Each port may be configured as either a:

- T (trunk) interface for links from a BRI Central Office
- S (subscriber) interface for connecting up to eight BRI devices to the controller

Note:

S interfaces support only basic call features such as calling number display for BRI devices. BRI call handling such as Hold or Transfer is not supported. BRI devices are not line-powered from the Quad BRI Framer.

The Quad BRI Framer requires a 300 MHz or faster processor.

The Quad BRI Framer MMC is a Field Replaceable Unit (FRU) that can be installed in any of the MMC sites in the front panel of the 3300 controller.

2.6.8.1 Specifications

Table 13: Quad BRI Framer MMC Specifications

Specification	Value
Channels	2 B-channels and 1 D-channel per link
Maximum Line Length	1 km (Point-to-Point) 250 m (Point-to-Multipoint) (See Note)

Note: In this table, Point-to-Multipoint (P2MP) refers to a physical P2MP configuration where more than one BRI set is connected to a single S interface. It does not refer to “logical” P2MP configurations such as DID trunks. P2MP is available for S interfaces only.

2.6.8.2 Pin Allocations

BRI connections require an 8-pin modular jack (RJ-45) on a shielded, twisted pair cable. Straight-through cables are required for “T” interfaces (to CO) and crossover cables (with 3 & 4 and 5 & 6 crossed at one end) for “S” interfaces (to Sets).

Table 14: Quad BRI Framer Pin Allocation

Pin Number	Signal
1	–
2	–
3	Tx+
4	Rx+
5	Rx-
6	TX-
7	–
8	–

2.6.9 AX and ASU II Specific Modules

Analog Line Cards (for AX and ASU II only)

Note:

Analog Line Cards support DTMF signaling only. Pulse (rotary) dial signaling is not supported

4 + 12 Port Combo Card

- Four Loop Start (LS) trunks for analog connection to a central office
- 12 On-Premise Station (ONS) Lines for analog phones
- Four System Fail Transfer (SFT) relays that provide direct connection between an analog telephone and a Loop Start trunk in the event of a system or power failure
- LS trunks and ONS lines connect to the module using a 25-pair female D-type (Amphenol) connector.

ONS Cards

- 16 On-Premise Station (ONS) Lines for analog phones

- 24 On-Premise Station (ONS) Lines for analog phones

Protected ONS ports (ONSP) are available on the

- 4 + 12 Port Combo card (can be used on the ASU II and the AX).
- 24 port and 16 port ONS card (can be used on the ASU II and the AX).

The ONSP ports are suitable for off-premise applications and meet the requirements of 60950-01 and IEC 55024. Regular ONS ports are intended for on-premise applications only.

ONS lines connect to the module using a 25-pair female D-type (Amphenol) connector.

ONSP ports use the same loss plan settings as regular ONS ports. You require a TDM license to enable each port.

Both the 4 + 12 Port Combo cards and ONS cards are hot-swappable.

LS CLASS

The AX and ASU II support Custom Local Access Signaling Services (CLASS) on the LS trunks and ONS lines. CLASS allows the 3300 ICP system to pass Calling Line ID digits and CLASS name information to display sets that support Caller ID functionality. The ASU II also supports ETSI signalling. The signalling type is set in the System Administration Tool.

2.6.9.1 AX/ASU II Specifications

ONS/ONSP

Table 15: ONS / ONSp Station Line Circuits

Attribute	AX/ASU II line cards
Battery Reversal ²	All regions
Constant Current	25 mA
DC Leakage Resistance Immunity	10 kΩ
Dial Pulse Detection	No
External Loop Drive Capability (Ringing Range)	1200 ¹ Ω for 2 REN, 900 Ω for 3 REN

Attribute	AX/ASU II line cards
Earth Recall detection	No
Ground Button detection	No
Ground Start detection	No
Loop Current Limit	25 mA (up to 1600 Ω , including DC resistance of set)
Loop Feed Type	constant
Loop status LED	per card
Low level diagnostics	Yes
Message Waiting Cadence	Hard-coded. 500 ms on/1500 ms off
Message Waiting Indication	Yes
DC Message Waiting Load Capability	2 sets supported (10 k Ω load per set)
DC Message Waiting Voltage	compat. with 90 V neon lamps (Strike voltage < 100 V) ⁴
Metering Generation	No
On-hook Transmission Capability ²	500 ms, current feed < 1 mA
Positive Disconnect	Yes
Ringing Frequency	20 Hz, 25 Hz, 50 Hz, balanced

Attribute	AX/ASU II line cards
Ringing Load Capability	<ul style="list-style-type: none"> • 16-port ONS card supports 2 REN (Ringing Equivalent Number) • 4 + 12 Port Combo Card supports 2 REN • 24-port ONSP card supports 3 REN
Ringing Type	balanced sinusoidal
Ringing Voltage (open cct)	55 Vrms
Timed Flash Detection	min. 100 ms

Note:

1. Approximately 6.9 miles (11 km) over 22-gauge, or 4.33 miles (6.98 km) over 24-gauge cable, or 2.72 miles (4.38 km) over 26 gauge. Minimum ringing signal across tip/ring 40 Vrms.

Cable length = (1200) / cable resistance per length).

Cable resistance:

22 gauge - 109 Ω / km (174 Ω / mile)

24 gauge - 172 Ω / km (277 Ω / mile)

26 gauge - 274 Ω / km (441 Ω / mile)

2. Used for sending CLID.
3. DC voltage method and CLASS message.
4. The MWI signal provided by the ASU II and AX is intended to be used with phones that support 90V signalling.

The ONS Circuit Impedance Values are the same as in Specification [ONS Circuit Impedance Values](#).

2.6.9.1.1 LS Trunk

[ONS Circuit Impedance Values](#) , and [Table 22: Recommended Transmission Specifications for North American LS Trunks](#) to [Table 23: Australia: LS Trunk Impedance Values](#) also apply to LS trunk circuits on 4 + 12 Port combo Card.

2.6.10 Analog Boards

Analog Main Board/Analog Option Board

Description

The MXe and CX(i) II Analog Main Boards (AMB) provide embedded analog connectivity. CX(i) II can expand to support an Analog Option Board (AOB).

Note:

1. The MXe Server and the AX do not support the Analog Main Board or the Analog Option Board.
2. The AMB and AOB support DTMF signaling only. Pulse (rotary) dial signaling is not supported.

The CXi II and MXe Controller (PN 50005090) with Analog Main Board (AMB) Version III support

- Six Loop Start (LS) trunks
- Four On-Premise (ONS) lines, (first two ONS ports have additional electrical protection; they use ONS loss plan settings)
- Two Power Fail Transfer (PFT)/System Fail Transfer (SFT) ports
- One Music On Hold (MOH) circuit
- One Loudspeaker Paging circuit.

The MXe Controller (PN 50005080) does not support protection for the ONS ports.

The CXi II Analog Option Board (AOB) supports an additional

- Six Loop Start (LS) trunks
- Four On-Premise (ONS) lines
- Two Power Fail Transfer (PFT)/System Fail Transfer (SFT) ports
- One Loudspeaker Paging circuit.

LS CLASS

Custom Local Area Signaling Services (CLASS) is supported on embedded LS trunks and ONS lines. CLASS allows the 3300 ICP system to pass Calling Line ID digits and CLASS name information to display sets that support Caller ID functionality.

ONS Lines

The ONS line circuits connect standard telephones with line loop resistances usually less than 400 ohms. The ONS line circuits are used to connect internal telephones close to the system. The ONS line circuit has the following features:

- On-hook signal transmission for CLASS function.
- Hardware ring trip with zero crossing.

- 48V tip and ring DC voltage in on-hook state.
- Off-hook detection by loop current.
- Software-controlled AC line and Balance impedance setting.
- First two ONS ports are protected (AMB Version III card only). Only the CX(i) II and MxEx Controller (PN 50005090) support protection for these ONS ports.

Table 16: ONS Station Line Circuits for the AMB⁴

Attribute	AMB (v1 to v3)
Battery Reversal	All regions
Constant Current	25 mA
DC Leakage Resistance Immunity	10 k Ω
Dial Pulse Detection	No
External Loop Drive Capability (Ringing Range)	1200 ¹ Ω for 2 REN, 900 Ω for 3 REN
Earth Recall detection	No
Ground Button detection	No
Ground Start detection	No
Loop Current Limit	25 mA (up to 1600 Ω including DC resistance of set)
Loop Feed Type	constant
Loop status LED	none
Low level diagnostics	Yes
Message Waiting Cadence	SW controlled. 300 ms on/1500 ms off

Attribute	AMB (v1 to v3)
Message Waiting Indication ³	Yes
DC Message Waiting Load Capability	Not supported
DC Message Waiting Voltage	No
Metering Generation	No
On-hook Transmission Capability ²	500 ms, current feed < 1 mA
Positive Disconnect	Yes
Ringing Frequency	20 Hz, 25 Hz or 50 Hz, balanced
Ringing Load Capability	2 REN (Ringing Equivalent Number)
Ringing Type	balanced sinusoidal
Ringing Voltage (open cct)	55 V rms
Timed Flash Detection	min. 100 ms

Note:

1. Approximately 6.9 miles (11 km) over 22-gauge, or 4.33 miles (6.98 km) over 24-gauge cable, or 2.72 miles (4.38 km) over 26 gauge. Minimum ringing signal across tip/ring 40 Vrms.

Cable length = (1200) / cable resistance per length).

Cable resistance:

22 gauge - 109 Ω / km (174 Ω / mile)

24 gauge - 172 Ω / km (277 Ω / mile)

26 gauge - 274 Ω / km (441 Ω / mile)

2. Used for sending CLID.
3. CLASS message only.
4. Supported on AMBv2 for CX only.
5. This table also applies to the protected ONS ports.

LS Trunks

The analog boards interface with analog central office (CO) trunks on a -48 Vdc loop start (LS). The LS trunk circuit has the following features:

- Ringing detection.
- On-hook signal reception for caller ID feature.
- Tip and ring voltage monitor.
- Software-controlled AC line impedance setting.
- Software-controlled audio gain settings in both transmit and receive path.
- Line reversal detection.

Power Fail Transfer (PFT)

The Power Fail Transfer (PFT) relays are activated by power loss (power fail transfer) or by software directed transfer (system fail transfer). The following events will close the relays:

- Failure of the controller
- Interruption of the system AC power
- A controller reset.

When the relays close, ONS 1 and ONS 2 on the AMB are automatically connected to the first two LS trunk circuits. After power is restored and communication is re-established with the controller, the relays open and the ONS and LS circuits function normally again.

When a system or network failure occurs, the controller checks for active calls on the ONS lines and will only switch the ONS phones when they are free. When the network recovers, the controller checks for loop

current on the CO lines (active calls) and will only switch to normal operating mode when no loop current is detected. This prevents the dropping of any ongoing connection through the CO line during the recovery of the system.

To prevent dial pulses or hook flashes from triggering a switch to normal mode, loop current breaks shorter than 560 ms are ignored.

You should plan carefully where you want the two ONS ports to terminate within the network. If power is lost they will provide the only connectivity to the telephone network.

The two LS trunks do not have to be dedicated to support power fail transfer. You can place them in a trunk group and use them to route calls to the central office during normal system operation.

Music On Hold (AMB)

The MOH interface supports the following features:

- Transformer coupled input with DC blocking capacitor and 600 ohms AC input impedance.
- Limited signal level going onto the PCM stream.
- Fixed A to D gain.

Paging (AMB)

The Paging interface supports the following features:

- Transformer-coupled front end for audio signal with 600 ohms AC input impedance.
- DC load (as in an LS trunk) for 3rd party paging unit control.
- One FORM C relay for 3rd party paging unit control.
- Paging and answer-back audio path can operate in full duplex mode.
- Fixed A to D gain and D to A gain.

2.6.10.1 Specifications

ONS Lines

Table 17: ONS Circuit Impedance Values

Territory	ONS Impedances		Ringing frequency
	Input	Balance	
Australia	220 Ω +(820 Ω 120nF)	220 Ω +(820 Ω 120nF)	25 Hz
Brazil	900 Ω	0 Ω +(800 Ω 50nF)	20 Hz

Territory	ONS Impedances		Ringing frequency
	Input	Balance	
China	200 Ω +(560 Ω 100nF)	200 Ω +(560 Ω 100nF)	25 Hz
France	270 Ω +(750 Ω 150nF)	270 Ω +(750 Ω 150nF)	50 Hz
New Zealand	370 Ω +(620 Ω 310nF)	370 Ω +(620 Ω 310nF)	25 Hz
NA/LA	600 Ω	600 Ω	20 Hz
UK/EU (except for France)	270 Ω +(750 Ω 150nF)	270 Ω +(750 Ω 150nF)	25 Hz

Note:

UK/EU parameters apply to Germany, Italy, Netherlands, Portugal, and Spain.

Protected ONS Lines

Protected ONS ports (ONSP) are available on

- ports 1 and 2 on the CXi II Controller with AMB Version III
- ports 1 and 2 on the MXe Controller (PN 50005090) with AMB Version III.

The ONSP ports are suitable for off-premise applications, and meet the requirements of 60950-01 and IEC 55-24. Regular ONS ports are intended for on-premise applications only.

ONSP ports use the same loss plan settings as regular ONS ports.

LS Trunks

Table 18: LS Trunk Signaling Protocols

AMB/AOB	LS Protocol
North America (NA) Latin America (LA)	TIA/EIA-464-C TIA/EIA-912
United Kingdom (UK)	UK Subscriber/Subsidiary Loop
United Kingdom (UK)	UK Loop Start Disconnect Clear
United Kingdom (UK) and Europe (EU)	CTR-21

Table 19: LS Trunk Specifications

Trunk Functions	Parameters		
Min. operating loop current	18 mA		
Max. operating loop current	100 mA		
Reversal detector	Detects CO battery polarity		
Loop detect for CO disc. (no battery)	< 2V across Tip and Ring		
Ring Detect Threshold	ASU	ASU II	AMB
for Ringing Frequency = 20 Hz	16 Vrms	30 Vrms	30 Vrms
for Ringing Frequency = 25 Hz	16 Vrms	25 Vrms	25 Vrms

Trunk Functions	Parameters		
for Ringing Frequency = 50 Hz	16 Vrms	20 Vrms	20 Vrms

Recommendations for Trunk Descriptor Settings

For best performance, analog trunks to the local exchange or Central Office should operate with an attenuation in the range of 0 dB to -8 dB. Higher attenuation will degrade the signal (both acoustic and DTMF dialing) and may make some connections, such as long-distance, difficult to use. Short loops provide the best performance.

The following trunk descriptors are recommended based on the amount of attenuation presented by the trunk line:

Table 20: Attenuation Levels for Short and Long CO Trunks

Trunk Category (CO Trunk Circuit Descriptor form)	Attenuation on Trunk Line
Short	0 dB to -3 dB
Long	-3 dB to -6 dB
(some additional signal loss will occur with lines of this length)	-6 dB to -8 dB CAUTION: Near maximum attenuation
Long (additional signal loss will occur with lines of this length; some connections will be difficult to use)	Greater than -8 dB Not acceptable

Trunk Category (CO Trunk Circuit Descriptor form)	Attenuation on Trunk Line
<p>Extra Long</p> <p>(this setting is valid when used with AMB/AOB or AX/ASU II LS trunks)</p> <p>This setting should only be used in situations where the attenuation on the trunk line is greater than -8 dB and the trunk is presenting usability problems.</p> <p>This connection provides additional gain with respect to the Long setting, but this additional gain is only applied on the signal transmitted from the CO to the ICP. This setting is identical to the Long setting for signals transmitted from the ICP to the CO.</p>	<p>Greater than -8 dB</p> <p>Not acceptable</p>

Note:

Use the LSMeasure Tool to determine the line settings for Loop Start (LS) trunks that are connected to an Analog Board in the controller, to a Universal ASU, or to an ASU II. Refer to the *3300 ICP Technician's Handbook* or the System Administration Tool online help for details.

For non-loaded loops, Bell (NA) recommends the following wire gauges:

Table 21: Recommended Trunk Lengths by Wire Size

Wire Size	Length Limit
26 AWG	15000 ft (~5 km) ~0.53 dB/1000 ft (~1.6 dB/km)
24 AWG	18000 ft (~5.8 km)
22 AWG	
19 AWG	

Note:

26 AWG = 0.4mm \ 22 AWG = 0.6mm

2.6.10.2 Recommendations for North American LS Trunks

The information in the following table is based on North American transmission specifications and is provided for North American installations. Other regions or countries will have similar specifications; refer to region- or country-specific specifications when installing product in regions other than North America.

For best performance, analog trunks should meet or exceed the “acceptable” values in the following table. If an analog trunk fails to meet the “acceptable” values the issue should be addressed with the service provider.

The values specified for Circuit Noise, Power Influence and 3 kHz Flat Circuit Noise assume a transmission level of 0 dB. For interface transmission levels other than 0 dB, the specified values should be shifted by a value that corresponds to the difference between the transmission level at that interface and 0 dB.

Table 22: Recommended Transmission Specifications for North American LS Trunks

Transmission Quality	Circuit Noise (dBrnC)	2 kHz Flat Circuit Noise (dBrn3kHz)	Power Influence (dBrnC)	Circuit Balance (dB)	Circuit Loss (dB)	Loop Current (mA)
Acceptable	≤20	≤40	≤80	≥60	≤6	≥23
Marginal	20-23	40-60	80-90	50-60	6-8	18-23
Unacceptable	≥25	≥60	≥90	≤50	≥8	≤18

dBrnC: Decibels above Reference Noise with C-message weighting.

dBrn3KHz: Decibels above Reference Noise with 3 KHz flat noise weighting.

2.6.10.3 Recommendations for UK LS Trunks

This following information is only relevant for installations in the UK:

- When connecting the 3300 ICP to Local Exchange lines via LS trunks it is important that the correct line type be used.
- The installer or system administrator should request that the Telco (e.g. BT), or carrier, provide trunks that are compatible to System X line type '0' (Subscriber lines) or line type '3' (business PBX/PABX lines).
- Both types of lines will work satisfactorily with the 3300 ICP, however line type '3' is the preferred line type for connecting a PBX/PABX.

2.6.10.4 LS Trunk Impedance Characteristics

The following tables provide the impedance values for each Balance Network Setting option (CO Trunk Circuit Descriptor form) depending on the country variant of the system.

Note:

“Non-IP” impedance values apply to trunks that are not connected to an IP port; and “IP” values apply to trunks that are connected to an IP port.

Table 23: Australia: LS Trunk Impedance Values

Balance Network Setting (CO Trunk Circuit Descriptor Form)	LS Impedance Values			
	Non-IP		IP	
	AC	Balance	AC	Balance
600	600Ω	600Ω	600Ω	600Ω
National Complex	200 Ω+ (820 Ω 120nF)	200 Ω+ (820 Ω 120nF)	200 Ω+ (820 Ω 120nF)	200 Ω+ (820 Ω 120nF)
TBR21	Same as "National Complex"	Same as "National Complex"	Same as "National Complex"	Same as "National Complex"
Alternate Complex	Same as "National Complex"	Same as "National Complex"	Same as "National Complex"	Same as "National Complex"
Spares 1, 2, 3, and 4	600 Ω	600 Ω	600 Ω	600 Ω

Note:

No difference between settings for IP or non-IP connections.

Table 24: Brazil: LS Trunk Impedance Values

Balance Network Setting (CO Trunk Circuit Descriptor Form)	LS Impedance Values			
	Non-IP		IP	
	AC	Balance	AC	Balance
600	600 Ω	600 Ω	600 Ω	600 Ω
National Complex	900 Ω	350 Ω+(1000 Ω 210nF)	600 Ω	0 Ω+(800 Ω 50nF)
TBR21	600 Ω	Same as "National Complex"	600 Ω	Same as "National Complex"
Alternate Complex	600 Ω	Same as "National Complex"	600 Ω	Same as "National Complex"
Spare 1	600 Ω	600 Ω	600 Ω	600 Ω
Spares 2, 3, and 4	600 Ω	600 Ω	600 Ω	600 Ω

Table 25: China: LS Trunk Impedance Values

Balance Network Setting (CO Trunk Circuit Descriptor Form)	LS Impedance Values			
	Non-IP		IP	
	AC	Balance	AC	Balance
600	600 Ω	600 Ω	600 Ω	600 Ω
National Complex	220 Ω+ (680 Ω 100nF)	220 Ω+ (680 Ω 100nF)	220 Ω+ (680 Ω 100nF)	220Ω+ (680Ω 100nF)

Balance Network Setting (CO Trunk Circuit Descriptor Form)	LS Impedance Values			
	Non-IP		IP	
	AC	Balance	AC	Balance
TBR21	Same as "National Complex"	Same as "National Complex"	Same as "National Complex"	Same as "National Complex"
Alternate Complex	Same as "National Complex"	Same as "National Complex"	Same as "National Complex"	Same as "National Complex"
Spares 1, 2, 3, and 4	600 Ω	600 Ω	600 Ω	600 Ω

Note:

No difference between settings for IP or non-IP connections.

Table 26: Europe: LS Trunk Impedance Values

Balance Network Setting (CO Trunk Circuit Descriptor Form)	LS Impedance Values			
	Non-IP		IP	
	AC	Balance	AC	Balance
600	600 Ω	600 Ω	600 Ω	600 Ω
National Complex	Same as "TBR21"	Same as "TBR21"	Same as "TBR21"	Same as "TBR21"
TBR-21	270 Ω+ (750 Ω 150nF)	270 Ω+ (750 Ω 150nF)	270 Ω+ (750 Ω 150nF)	270 Ω+ (750 Ω 150nF)
Alternate Complex	Same as "TBR21"	Same as "TBR21"	Same as "TBR21"	Same as "TBR21"

Balance Network Setting (CO Trunk Circuit Descriptor Form)	LS Impedance Values			
	Non-IP		IP	
	AC	Balance	AC	Balance
Spares 1, 2, 3, and 4	600 Ω	600 Ω	600 Ω	600 Ω

Note:

No difference between settings for IP or non-IP connections.

Note:

EU countries: France, Germany, Italy, the Netherlands, Portugal, and Spain.

Table 27: New Zealand: LS Trunk Impedance Values

Balance Network Setting (CO Trunk Circuit Descriptor Form)	LS Impedance Values			
	Non-IP		IP	
	Non-IP	Balance	AC	Balance
600	600 Ω	600 Ω	600 Ω	600 Ω
National Complex	370 Ω+ (620 Ω 310nF)	370 Ω+ (620 Ω 310nF)	370 Ω+ (620 Ω 310nF)	370 Ω+ (620 Ω 310nF)
TBR21	Same as "National Complex"	Same as "National Complex"	Same as "National Complex"	Same as "National Complex"
Alternate Complex	Same as "National Complex"	Same as "National Complex"	Same as "National Complex"	Same as "National Complex"

Balance Network Setting (CO Trunk Circuit Descriptor Form)	LS Impedance Values			
	Non-IP		IP	
	Non-IP	Balance	AC	Balance
Spares 1, 2, 3, and 4	600 Ω	600 Ω	600 Ω	600 Ω

i Note:

No difference between settings for IP or non-IP connections.

Table 28: North America: LS Trunk Impedance Values

Balance Network Setting (CO Trunk Circuit Descriptor Form)	LS Impedance Values			
	Non-IP		IP	
	AC	Balance	AC	Balance
600	600 Ω	600 Ω	600 Ω	600 Ω
National Complex	600 Ω	350 Ω + (1000 Ω//210nF)	600 Ω	350 Ω + (1000 Ω//210nF)
TBR21	600 Ω	350 Ω + (1000 Ω//210nF)	600 Ω	AMB/AOB V1: 100 Ω + (1000 Ω//45nF) AMB/AOB V2/V3, ASU II and AX: 100 Ω + (1050 Ω//60nF)
Alternate Complex	600 Ω	350Ω + (1000 Ω//210nF)	600 Ω	100 Ω + (1400 Ω//130nF)

Balance Network Setting (CO Trunk Circuit Descriptor Form)	LS Impedance Values			
	Non-IP		IP	
	AC	Balance	AC	Balance
Spare 1 for 64AMB V1 hardware	600 Ω	350 Ω + (1000 Ω //210nF)	600 Ω	AMB/AOB V1: 100 Ω + (1600 Ω //33nF) AMB/AOB V2/V3, ASU II and AX: 100 Ω + (1800 Ω //10nF)
Spare 1 for 64AMB / AOBV2 hardware	600 Ω	350 Ω + (1000 Ω //210nF)	600 Ω	AMB/AOB V1: 100 Ω + (1600 Ω //33nF) AMB/AOB V2/V3, ASU II and AX: 100 Ω + (1800 Ω //10nF)
Spare 2	600 Ω	350 Ω + (1000 Ω //210nF)	600 Ω	130 Ω + (1500 Ω //165nF)
Spare 3	600 Ω	600 Ω	600 Ω	10 Ω + (1000 Ω //8nF)
Spare 4	600 Ω	600 Ω	600 Ω	600 Ω

Note:

The 600 ohm setting is most often used for very short connections, such as those behind a PBX, IAD or similar device.

Note:

National Complex matches most unloaded central office lines. It is the most commonly used setting.

Table 29: Latin America: LS Trunk Impedance Values

Balance Network Setting (CO Trunk Circuit Descriptor Form)	LS Impedance Values			
	Non-IP		IP	
	AC	Balance	AC	Balance
600	600 Ω	600 Ω	600 Ω	600 Ω
National Complex	600 Ω	350 Ω+(1000 Ω 210nF)	600 Ω	370 Ω+(1000 Ω 210nF)
TBR21	600 Ω	Same as "National Complex"	600 Ω	470 Ω+(800 Ω 150nF)
Alternate Complex	600 Ω	Same as "National Complex"	600 Ω	560 Ω+(1500 Ω 330nF)
Spare 1	600 Ω	600 Ω	600 Ω	600 Ω
Spares 2, 3, and 4	600 Ω	600 Ω	600 Ω	600 Ω

Note:

The 600 ohm setting is most often used for very short connections, such as those behind a PBX, IAD or similar device.

Note:

National Complex matches most unloaded central office lines. It is the most commonly used setting.

Table 30: UK: LS Trunk Impedance Values

Balance Network Setting (CO Trunk Circuit Descriptor Form)	LS Impedance Values			
	Non-IP		IP	
	AC	Balance	AC	Balance
600	600 Ω	600 Ω	600 Ω	600 Ω
National Complex	370 Ω + (620 Ω 310nF)	370 Ω + (620 Ω 310nF)	370 Ω + (620 Ω 310nF)	370 Ω + (620 Ω 310nF)
TBR21	270 Ω + (750 Ω 150nF)	270 Ω + (750 Ω 150nF)	270 Ω + (750 Ω 150nF)	270 Ω + (750 Ω 150nF)
Alternate Complex	Same as "National Complex"	Same as "National Complex"	Same as "National Complex"	Same as "National Complex"
Spares 1, 2, 3, and 4	600 Ω	600 Ω	600 Ω	600 Ω

Note:

There is no difference between settings for IP and non-IP connections.

2.6.11 Music on Hold and Paging Specifications

Music On Hold

Note:

Music on Hold is not supported on the ASU II.

Table 31: MOH Electrical Specifications

Input impedance	600 ohms nominal
-----------------	------------------

Maximum input voltage	SELV limits
Maximum input audio level without clipping	0.4 Vrms (mono input)/0.2 Vrms (each stereo input), THD @ -40 dB
Maximum PCM level	-15 dBm

2.6.11.1 Paging

Note:

Paging is not supported on the ASU II.

Table 32: Paging Electrical Specifications

AC input impedance	600 ohms nominal
DC load	300 to 100 ohms for loop current 20 mA to 90 mA
Maximum DC current	90 mA with PAGE1 and PAGE2 leads
Maximum input voltage	SELV limits to all connections
A to D gain	+3 dB
D to A gain	-3 dB
D to D loss	> 25 dB @ 1 kHz
Maximum relay rating	0.5 A 40 Vac, 2 A 30 Vdc

2.6.11.2 Pin Allocations

CXi II and MXe Line and Trunk Connector

Table 33: RJ-11 Line/Trunk Connector Pin Allocation

Port	Pin Number	Function
LS 1 - 6	3	Ring
	4	Tip
ONS 1 - 4	3	Ring
	4	Tip
ONS 3 - 4	2	Contact sensor
	5	Contact sensor
Relay 1/2 (not used)	3	RLY1_Common
	4	RLY1_NO (normally open)
	6	RLY1_NC (normally closed)
	2	RLY2_Common
	5	RLY2_NO (normally open)
Paging	3	Paging signal
	4	Paging signal

Port	Pin Number	Function
	6	Not used
	2	Paging relay common
	5	Paging relay NO (normally open)
	1	Paging relay NC (normally closed)

Music On Hold Connector

The Music On Hold port uses a 3.5 mm stereo jack for input-signal connection. It will also accept a 3.5 mm mono plug.

Table 34: MOH Connector

Conductor conductor	Signal
SHIELD	MOH_COM
RING	MOH_1
TIP	MOH_2

Note:

The two input signals are equivalent to the left and right channel signals from a stereo source and are combined internally into a single channel.

Paging Connector

Table 35: Paging Connector

Pin Number	Signal
1	Common contact
2	Normally closed contact
3	Normally open contact
4	Page1 (Tip)
5	Page2 (Ring)
6	No connection
7	Not used
8	Not used

This chapter contains the following sections:

- [Analog Services Units](#)
- [ASU II Transmission Standards](#)
- [Circuit Descriptions](#)
- [Pin Allocations](#)

3.1 Analog Services Units

Description

Mitel Analog Services Units (ASUs) provide connectivity for analog trunks and telephones (On-Premise Station (ONS) and POTS) to the 3300 ICP system. There are three variants:

- Analog Services Unit II
- Analog Services Unit
- Universal Analog Services Unit.

The 3300 ICP system supports up to four Analog Services Units in any combination.

Table 36: Trunk Support by ASU Type

ASU Type	Number of Analog Ports Supported (ONS)	Number of LS Trunks Supported
ASU II	48	8
ASU	24	0
Universal ASU	24	4

Note:

1. The ASUs (all variants) support DTMF signaling only. Pulse (rotary) dial signaling is not supported.
2. The ASU II is supported in China and Brazil. The ASU and Universal ASU are not supported in China or Brazil.
3. The ASU II supports LS CLASS trunks; however, the ASU and the Universal ASU do not support LS CLASS trunks.

3.1.1 Analog Services Unit II (ASU II)

The ASU II chassis supports up to 48 ONS phones or up to 8 LS trunks depending on how the unit is configured with peripheral cards. See [AX and ASU II Specific Modules](#) for descriptions of modules you can use in the ASU II.



Figure 15: Analog Services Unit II Front Panel

The Analog Services Unit II front panel contains:

- Alarm, activity, and power LEDs
- One CIM port for connecting to the Controller.

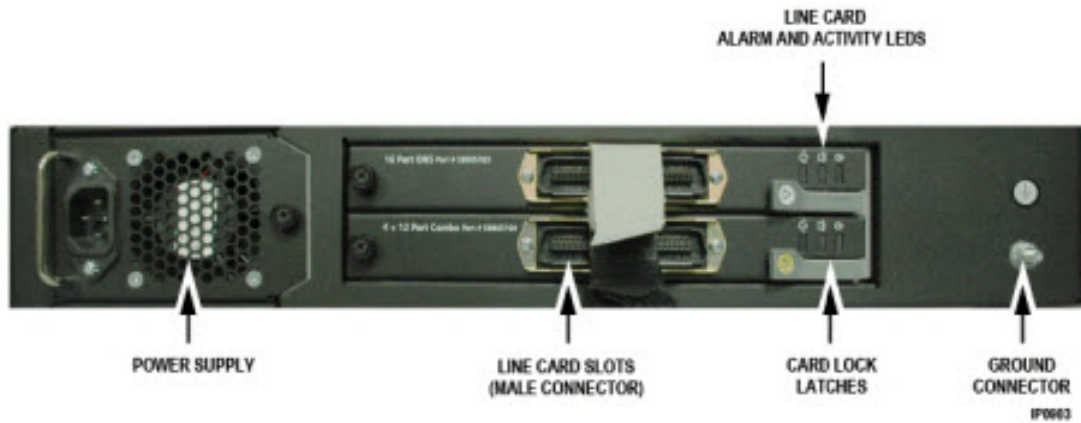

Figure 16: Analog Services Unit II Rear Panel

The Analog Services Unit II rear panel contains:

- Power supply and fan
- Two slots for analog line cards (see [Analog Line Cards \(for AX and ASU II only\)](#))
- Protective ground for grounding the chassis.

3.1.2 Analog Services Unit

The ASU is the On-Premise Station (ONS) line unit. It supports up to 24 ONS phones. The unit does not support LS trunks, Music on Hold, or Loudspeaker paging.

Custom Local Access Signaling Services (CLASS) allows the 3300 ICP system to pass Calling Line ID digits and CLASS name information to ONS display sets that support Caller ID functionality.

CLASS trunks are not supported on the ASU.

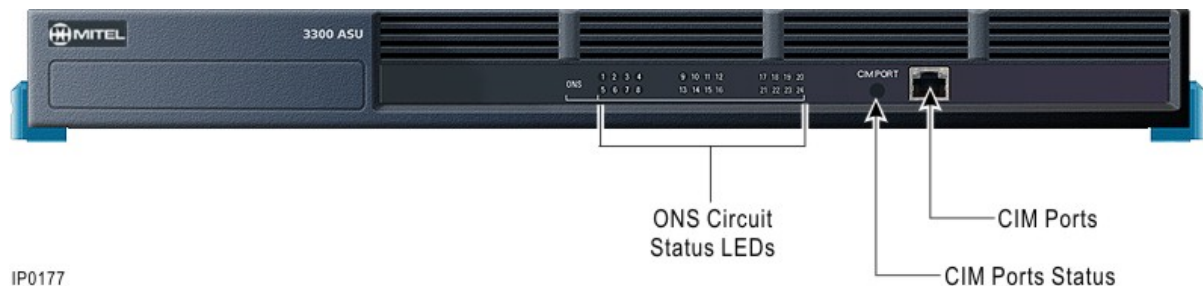

Figure 17: Analog Services Unit Front Panel

The Analog Services Unit front panel provides

- 24 ONS circuit status LEDs
- One CIM port for connecting to the Controller

- CIM status LEDs.

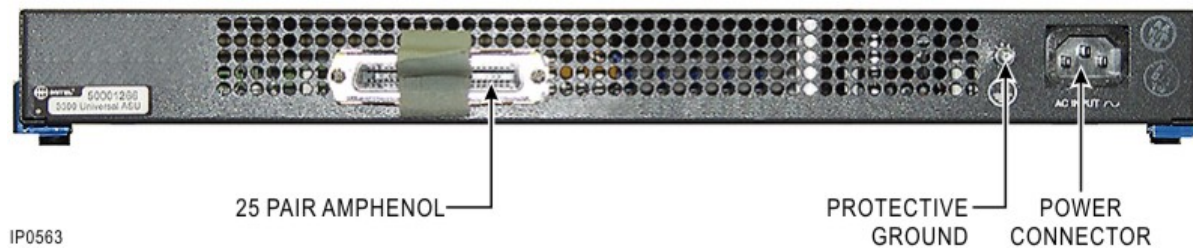

Figure 18: Analog Services Unit Rear Panel

The Analog Services Unit rear panel provides

- Female 25-pair Amphenol trunk/line connector (ONS Tip/Ring or A/B circuits)
- Protective ground for grounding the chassis
- Input power connector (standard male IEC320 AC).

3.1.3 Universal Analog Services Unit

The Universal ASU is a combination unit that supports:

- 16 On-Premise Station (ONS) Lines for analog phones
- Four Loop Start (LS) trunks for analog connection to a central office
- Four Music On Hold ports (only one is software-supported) for connecting a MOH device
- Two Paging ports for connecting a loudspeaker paging unit
- Four System Fail Transfer (SFT) relays that provide direct connection between an analog telephone and a Loop Start trunk in the event of a system or power failure.

Note:

1. CLASS trunks are not supported on the Universal ASU.
2. Custom Local Access Signaling Services (CLASS) allows the 3300 ICP system to pass Calling Line ID digits and CLASS name information to ONS display sets that support Caller ID functionality.

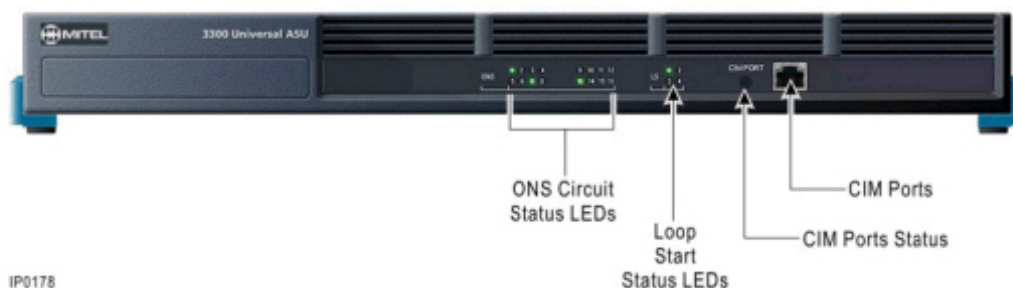

Figure 19: Universal Analog Services Unit Front Panel

The Universal Analog Services Unit front panel contains:

- 16 ONS circuit status LEDs
- Four loop start status LEDs
- One CIM port and status LEDs.

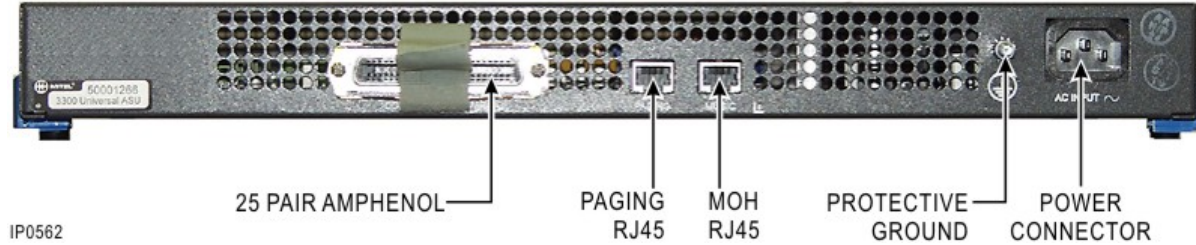

Figure 20: Universal Analog Services Unit Rear Panel

The Universal Analog Services Unit rear panel provides:

- Female 25-pair Amphenol trunk/line connector (LS and ONS Tip/Ring or A/B circuits)
- One paging connector (supports two paging ports)
- One music on hold (MOH) connector
- Protective ground for grounding the chassis
- Input power connector (standard male IEC320 AC).

3.1.3.1 Music On Hold (Universal ASU only)

The MOH interface provides four physical ports for Music on Hold. However, only one port (of ports 1 or 2) is supported through system software.

Each MOH port provides:

- 600 ohm input impedance
- Signal level overload protection as mandated by FCC part 68 on encoded analog content
- Dry Tip/Ring interface (no battery)
- Always active input (no external control required or provided).

The connection requires a cable with a 3.5 mm mono jack on one end and an 8-pin modular jack (RJ-45) on the other end. The RJ-45 plugs into the Music On Hold port on the rear panel of the Universal ASU; the 3.5 mm mono jack plugs into the output connector on the music source (for example, radio). If you use a stereo jack, short the left and right channels of the jack.

Table 37: Music on Hold Connector Pin Allocation

Pin Number	signal	Pin Number	signal
1	Tip 1	5	Ring 3

Pin Number	signal	Pin Number	signal
2	Ring 1	6	Ring 2
3	Tip 2	7	Tip 4
4	Tip 3	8	Ring 4

Note:

Music on Hold can be assigned to either of the first two ports on a Universal ASU E&M card or to the E&M port on the Analog Main Board (AMB) (on a controller with embedded analog). Only one Music on Hold source is permitted per system.

3.1.3.2 Paging (Universal ASU only)

The paging interface provides two paging ports.

Each paging port is a transformer-coupled interface providing:

- 600 ohm input impedance
- Full duplex capability
- A complete 2/4 wire hybrid interface
- A balance impedance set at 600 ohms.

The two overhead paging outputs, in combination with their relay contacts, support two paging zones.

Table 38: ASU Paging Zones vs. Audio Circuit Numbers and Relay Positions

ASU Paging Zone Number	Paging Audio Circuit Number	Paging Circuit's Relay Position
1	1	Off
1		
2	1	On
3	2	Off

ASU Paging Zone Number	Paging Audio Circuit Number	Paging Circuit's Relay Position
4	2	On
0	1 & 2	Off & Off

Paging is accomplished by one of two methods:

- Zone control via outputted DTMF digits
- E&M trunk emulation using contact-closure control.

The Paging Connector Pin Allocation is shown in the following table.

Table 39: Paging Connector Pin Allocation

Pin	signal	Zone
1	Tip	00
2	Ring	00
3	Common contact	00
4	Tip	01
5	Ring	01
6	Normally open contact	00
7	Common contact	01
8	Normally open contact	01

Note:

1. The Paging port is a standard 8-pin modular RJ-45 connector located on the rear panel of the Universal ASU.
2. Each paging port has a tip/ring pair for audio and a second tip/ring pair contact closures for zone control. The contact closes when paging on zones.

3.2 ASU II Transmission Standards

There is only one variant of the ASU II. [Table 40: Supported Transmission Standards](#) lists the transmission standards supported on the ASU II. [Table 18: LS Trunk Signaling Protocols](#) lists the LS trunk signalling protocols supported on the ASU II.

Table 40: Supported Transmission Standards

Region	Transmission Standards
North America (NA) Latin America (LA)	TIA/EIA-912-A ANSI/EIA/TIA 464-C
United Kingdom (UK)	UK Subscriber/Subsidiary Loop UK Loop Start Disconnect Clear CTR-21
Europe (EU)	CTR-21 ETSI ES 202 020 "Harmonized Pan-European American loss and level plan for voice gateways to IP-based networks"
China	YD-344-90
Brazil	ANEXO Á RESOLUÇÃO # 390

Region	Transmission Standards
Australia	AS/ACIF S003:2001 S002/S003
New Zealand	PTC220, PTC 109, PTC 207, PTC 217

i Note: EU countries: France, Germany, Italy, The Netherlands, Portugal, and Spain.

3.3 Circuit Descriptions

On-Premise Station Lines

Table 41: ONS Station Line Circuits by ASU type

Attribute	ASU II5	ASU
Battery Reversal ³	all regions	UK, LA and EU only
Constant current	25 mA	25 mA
DC Leakage Resistance Immunity	10 kohm	10 kohm
Dial Pulse Detection	No	No
External Loop Drive Capability (Ringing Range)	1200 ² ohm	600 ¹ ohm
Earth Recall detection	No	No
Ground Button detection	No	Yes
Ground Start detection	No	No

Loop Current limit	25 mA ⁶	25 mA ⁶
Loop Feed type	constant	constant
Loop status LED	per card	per circuit
Low level diagnostics	Yes	Yes
Message Waiting Cadence	See Message Waiting Parameters	
Message Waiting indication ⁴	Yes	Yes
DC Message Waiting Load capability ³	2 sets ⁸ supported	2 sets ⁸ supported
DC Message Waiting voltage	compat. with 90 V neon lamps ⁷	compat. with 90 V neon lamps ⁷
Metering generation	No	No
On-hook Transmission capability ³	500 ms, current feed < 1 mA	Yes
Positive Disconnect	Yes	Yes
Ringling Frequency	Country-specific, see ONS Circuit Impedance Values	
Ringling Load capability	<ul style="list-style-type: none"> • 16-port ONS card supports 2 REN (Ringling Equivalent Number) • 4 + 12 Port Combo Card supports 2 REN • 24-port ONSP card supports 3 REN 	3 REN

Ringling type	balanced sinusoidal	unbalanced sinusoidal
Ringling voltage (open cct)	55 Vrms	65 Vrms
Timed Flash detection	min. 100 ms	min. 100 ms

Note:

1. Approximately 0.68 mile (1.1 km) of loop range over 26-gauge cable with 300 ohm set.
2. Approximately 5.17 miles (8.28 km) over 22-gauge cable with 300 ohm set, or 3.25 miles (5.19 km) over 24-gauge cable with 300 ohm set, or 2 miles (3.2 km) over 26-gauge cable with 300 ohm set. - Minimum 40 Vrms

Cable length = (1200 - set offhook DC resistance) / cable resistance per length

Cable resistance:

- 22 gauge - 109 Ω / km (174 W / mile)
- 24 gauge - 172 Ω / km (277 W / mile)
- 26 gauge - 274 Ω / km (441 W / mile)

3. Used for sending CLID.
4. CLASS message only.
5. The MWI signal provided by the ASU II and the AX is intended to be used with phones that support 90 V signaling.
6. Up to 1600 ohms (including DC resistance of set)
7. Strike voltage < 100 V. The MWI signal provided by ASU is intended to be used with phones that support 90V signaling.
8. 10 Kohm per set.

Protected ONS Ports

Protected ONS ports (ONSP) are available on:

- the ONS/LS combo card (can be used on the ASU II and the AX)
- the 16 and 24 port ONS cards (can be used on the ASU II and the AX)
- ports 1 and 2 on the CXi to CXi II Controllers with AMB Version III
- ports 1 and 2 on the CXi/CXi II and Mx Controller (PN 50005090) with AMB Version III

The ONSP ports are suitable for off-premise applications and meet the requirements of 60950-01 and IEC 55024. Regular ONS ports are intended for on-premise applications only. ONSP ports use the same loss plan settings as regular ONS ports.

3.3.1 Loop Start Trunks

Table 42: Loop Start Trunks by ASU Type

Attribute	ASU II	ASU
50 Hz Meter Pulse Detection	No	UK only
Loop Disconnect and Loop Reversal Detection	Yes	Yes
Incoming Ring Detection	Yes	Yes
Status LED	per card	per circuit

3.3.2 System Fail Transfer (SFT)

System Fail Transfer (SFT) relays are available on the

- Analog Main Board (AMB) for the CXi to CXi II, and MXe controllers
- Universal ASU, and
- ASU II or AX controller with a 4 + 12 Combo Card.

The AMB for the CXi II and MXe controllers provides two System Fail Transfer (SFT) relays. The Universal ASU and the Combo card each provide four System Fail Transfer (SFT) relays, one per LS trunk circuit. If any of the following events occur, the relays close:

- Failure of the 3300 ICP controller
- Interruption of the system AC power
- Universal ASU reset
- Loss of the CIM link between the 3300 Controller and ASU.

When the relays close, ONS ports are automatically connected to the LS trunk circuits. After power is restored and communication is re-established with the controller, the relays open and the ONS and LS circuits function normally. Any SFT or PFT calls in progress are not cut off. Relays are switched on a per-circuit basis after the termination of any SFT or PFT (Power Fail Transfer) call.

The System Fail Transfer ONS ports are physically mapped to the LS trunks as follows:

Table 43: ONS Port Circuit Assignment to LS Trunk Circuit

Universal ASU		ASU II or AX controller with 4 + 12 Combo Card		AMB in MXe	
ONS Port Circuits	LS Trunk Circuits	ONS Port Circuits	LS Trunk Circuits	ONS Port Circuits	LS Trunk Circuits
13	1	1	1	1	1
14	12	2	2	2	2
15	3	3	3		
16	4	4	4		

You should plan carefully where you want the ONS ports to terminate within the network. If power is lost they will provide the only connectivity to the telephone network. The LS trunks do not have to be dedicated to support system fail transfer. You can place them in a trunk group and use them to route calls to the central office during normal system operation.

3.4 Pin Allocations

ASU II Line and Trunk Connector

ONS lines and LS trunks are connected using a 25-pair D-type (Amphenol) connector.

Table 44: 25-pair Connector Pin Allocation

Pin Number	Signal			Pin Number	Signal		
	24 Port ONS	16 Port ONS	4 + 12 Combo		24 Port ONS	16 Port ONS	4 + 12 Combo
1	ONS Ring 1	ONS Ring 1	ONS Ring 1	26	ONS Tip 1	ONS Tip 1	ONS Tip 1
2	ONS Ring 2	ONS Ring 2	ONS Ring 2	27	ONS Tip 2	ONS Tip 2	ONS Tip 2

Pin Number	Signal			Pin Number	Signal		
	24 Port ONS	16 Port ONS	4 + 12 Combo		24 Port ONS	16 Port ONS	4 + 12 Combo
3	ONS Ring 3	ONS Ring 3	ONS Ring 3	28	ONS Tip 3	ONS Tip 3	ONS Tip 3
4	ONS Ring 4	ONS Ring 4	ONS Ring 4	29	ONS Tip 4	ONS Tip 4	ONS Tip 4
5	ONS Ring 5	ONS Ring 5	ONS Ring 5	30	ONS Tip 5	ONS Tip 5	ONS Tip 5
6	ONS Ring 6	ONS Ring 6	ONS Ring 6	31	ONS Tip 6	ONS Tip 6	ONS Tip 6
7	ONS Ring 7	ONS Ring 7	ONS Ring 7	32	ONS Tip 7	ONS Tip 7	ONS Tip 7
8	ONS Ring 8	ONS Ring 8	ONS Ring 8	33	ONS Tip 8	ONS Tip 8	ONS Tip 8
9	ONS Ring 9	ONS Ring 9	ONS Ring 9	34	ONS Tip 9	ONS Tip 9	ONS Tip 9
10	ONS Ring 10	ONS Ring 10	ONS Ring 10	35	ONS Tip 10	ONS Tip 10	ONS Tip 10
11	ONS Ring 11	ONS Ring 11	ONS Ring 11	36	ONS Tip 11	ONS Tip 11	ONS Tip 11
12	ONS Ring 12	ONS Ring 12	ONS Ring 12	37	ONS Tip 12	ONS Tip 12	ONS Tip 12
13	ONS Ring 13	ONS Ring 13		38	ONS Tip 13	ONS Tip 13	

Pin Number	Signal			Pin Number	Signal		
	24 Port ONS	16 Port ONS	4 + 12 Combo		24 Port ONS	16 Port ONS	4 + 12 Combo
14	ONS Ring 14	ONS Ring 14		39	ONS Tip 14	ONS Tip 14	
15	ONS Ring 15	ONS Ring 15		40	ONS Tip 15	ONS Tip 15	
16	ONS Ring 16	ONS Ring 16		41	ONS Tip 16	ONS Tip 16	
17	ONS Ring 17			42	ONS Tip 17		
18	ONS Ring 18			43	ONS Tip 18		
19	ONS Ring 19			44	ONS Tip 19		
20	ONS Ring 20			45	ONS Tip 20		
21	ONS Ring 21		LS Ring 1	46	ONS Tip 21		LS Tip 1
22	ONS Ring 22		LS Ring 2	47	ONS Tip 22		LS Tip 2
23	ONS Ring 23		LS Ring 3	48	ONS Tip 23		LS Tip 3
24	ONS Ring 24		LS Ring 4	49	ONS Tip 24		LS Tip 4
25			N/C	50			N/C

3.4.1 ASU and Universal ASU Line and Trunk Connector

ONS lines and LS trunks are connected using a 25-pair male D-type (Amphenol) connector.

Table 45: 25-pair Connector Pin Allocation

Pin Number	Signal		Pin Number	Signal	
	Universal ASU	ASU		Universal ASU	ASU
1	ONS Tip 1	ONS Tip 1	26	ONS Ring 1	ONS Ring 1
2	ONS Tip 2	ONS Tip 2	27	ONS Ring 2	ONS Ring 2
3	ONS Tip 3	ONS Tip 3	28	ONS Ring 3	ONS Ring 3
4	ONS Tip 4	ONS Tip 4	29	ONS Ring 4	ONS Ring 4
5	ONS Tip 5	ONS Tip 5	30	ONS Ring 5	ONS Ring 5
6	ONS Tip 6	ONS Tip 6	31	ONS Ring 6	ONS Ring 6
7	ONS Tip 7	ONS Tip 7	32	ONS Ring 7	ONS Ring 7
8	ONS Tip 8	ONS Tip 8	33	ONS Ring 8	ONS Ring 8
9	ONS Tip 9	ONS Tip 9	34	ONS Ring 9	ONS Ring 9
10	ONS Tip 10	ONS Tip 10	35	ONS Ring 10	ONS Ring 10
11	ONS Tip 11	ONS Tip 11	36	ONS Ring 11	ONS Ring 11
12	ONS Tip 12	ONS Tip 12	37	ONS Ring 12	ONS Ring 12
13	ONS Tip 13	ONS Tip 13	38	ONS Ring 13	ONS Ring 13

Pin Number	Signal		Pin Number	Signal	
	Universal ASU	ASU		Universal ASU	ASU
14	ONS Tip 14	ONS Tip 14	39	ONS Ring 14	ONS Ring 14
15	ONS Tip 15	ONS Tip 15	40	ONS Ring 15	ONS Ring 15
16	ONS Tip 16	ONS Tip 16	41	ONS Ring 16	ONS Ring 16
17	LS Tip 1	ONS Tip 17	42	LS Ring 1	ONS Ring 17
18	LS Tip 1-1	ONS Tip 18	43	LS Ring 1-1	ONS Ring 18
19	LS Tip 2	ONS Tip 19	44	LS Ring 2	ONS Ring 19
20	LS Tip 1-2	ONS Tip 20	45	LS Ring 1-2	ONS Ring 20
21	LS Tip 3	ONS Tip 21	46	LS Ring 3	ONS Ring 21
22	LS Tip 1-3	ONS Tip 122	47	LS Ring 1-3	ONS Ring 22
23	LS Tip 4	ONS Tip 23	48	LS Ring 4	ONS Ring 23
24	LS Tip 1-4	ONS Tip 24	49	LS Ring 1-4	ONS Ring 24
25	N/C	N/C	50	N/C	N/C

3.4.1.1 CIM Port

The CIM ports require standard 8-pin modular jacks (RJ-45) consisting of 2 balanced signal pairs on a Category 5 Universal Twisted Pair (UTP) crossover cable. The twisted pairs are arranged as: 1,2; 3,6; 4,5; 7,8. Each tied pair is connected to a 75 ohm resistor. The following table lists the signal for each pin.

Table 46: CIM Port Pin Allocation

Pin Number	Signal	Pin Number	Signal
1	RX+	5	–
2	RX-	6	TX-
3	TX+	7	–
4	–	8	–

3.4.2 ASU II ONS Parameters

The ASU II ONS parameters are the same as those for the Analog Boards; please refer to [Table 17, “ONS Circuit Impedance Values,”](#).

3.4.3 ASU and Universal ASU ONS Parameters

ONS Transmission Parameters

Table 47: Transmission Parameters

ASU variant	Input Impedance	Balance Impedance
NA	600 ohms	600 ohms
UK ^{1UK}	300 Ω+(1000 Ω 220nF)	300 Ω+(1000 Ω 220nF)
LA ²	600 ohms	600 ohms
EU ³	270 Ω+(750 Ω 150nF)	270 Ω+(750 Ω 150nF)

1. The UK ASU is used in the United Kingdom and New Zealand.
2. The LA ASU is used in Latin America, including Brazil.
3. The EU ASU is used in Australia, France, German, Italy, Netherlands, Portugal, and Spain.

ONS DC Supervision Parameters

Table 48: DC Supervision Parameters

DC Supervision	Parameters
Battery Feed	-30 Vdc feed, constant current set at 25 mA \pm 1 mA
Loop Resistance	600 ohms (includes set)
Loop-Detect Threshold	12 mA
Flash Detect	SW timed function from switch hook detector
Ground button detect threshold	13 mA Tip or Ring to ground in off hook state
Positive Disconnect	SW timed function that breaks loop current

ONS Ringing Parameters

Table 49: Ringing Parameters

Ringing	Parameters
Voltage	65 Vrms sine wave superimposed onto -48 Vdc
Frequency	20 Hz (NA/LA ¹) 25 Hz (UK ² /EU ³)
Trip Battery: Silent interval	-30 Vdc
Ring Interval	-50 Vdc
Number of bridged ringers	3
Max. bridged capacitance	3nF 15k ohms

Ringling	Parameters
Ring Trip detect time	HW detector response <100 ms HW ring trip overrides application of ringing signal
SW ring trip response time	Within 50 ms of switch hook detect
<ol style="list-style-type: none"> 1. The LA ASU is used in Latin America (excepting Brazil). 2. The UK ASU is used in the United Kingdom and New Zealand. 3. The EU ASU is used in Australia, France, German, Italy, Netherlands, Portugal, and Spain. 	

ONS Message Waiting Parameters

Table 50: Message Waiting Parameters

Message Waiting	Parameters
Voltage	-115 Vdc \pm 5V dc
Source Impedance	Between 2k and 4K
MSW trip	SW control, interlocks with application of ringing
Flash Rate	Cadenced, SW controlled. 300 ms on/1500 ms off cont. AX and ASU II: hard-coded 500 ms on/1500 ms off

3.4.4 ASU II LS Trunk Parameters

The ASU II LS Trunk parameters are the same as those for the Analog Boards. The parameters for Analog Boards are detailed in the following tables:

- [Table 18, “LS Trunk Signaling Protocols,”](#)
- [Table 19, “LS Trunk Specifications,”](#)
- [Table 20, “Attenuation Levels for Short and Long CO Trunks,”](#)
- [Table 21, “Recommended Trunk Lengths by Wire Size,”](#) on page 49

3.4.5 LS Trunks Selection in the UK

This following information is only relevant for installations in the UK:

- When connecting the 3300 ICP to Local Exchange lines via LS trunks it is important that the correct line type be used.
- The installer or system administrator should request that the Telco (e.g. BT), or carrier, provide trunks that are compatible to System X line type '0' (Subscriber lines) or line type '3' (business PBX/PABX lines).

Both types of lines will work satisfactorily with the 3300 ICP, however line type '3' is the preferred line type for connecting a PBX/PABX.

3.4.6 LS Trunks, Acceptable Noise Levels

The information in the following table is based on North American transmission specifications and is provided for North American installations. Other regions or countries will have similar specifications which should be referred to when installing product in regions other than North America.

For best performance, analog trunks should meet or exceed the "acceptable" values in the following table. If an analog trunk fails to meet the "acceptable" values the issue should be addressed with the service provider.

The values specified for Circuit Noise, Power Influence and 3 kHz Flat Circuit Noise assume a transmission level of 0 dB. For interface transmission levels other than 0 dB, the specified values should be shifted by a value that corresponds to the difference between the transmission level at that interface and 0 dB.

Table 51: Transmission Quality

Transmission Quality	Circuit Noise (dBrnC)	2 kHz Flat Circuit Noise (dBrn3kHz)	Power Influence (dBrnC)	Circuit Balance (dB)	Circuit Loss (dB)	Loop Current (mA)
Acceptable	≤20	≤40	≤80	≥60	≥6	≥23
Marginal	20-23	40-60	80-90	50-60	6-8	18-23
Unacceptable	≥25 ≥25	≥60	≥90	≤50	≤8	≤18

dBrnC: Decibels above Reference Noise with C-message weighting. dBrn3KHz: Decibels above Reference Noise with 3 KHz flat noise weighting.

The following tables provide the impedance values for each Balance Network Setting option (CO Trunk Circuit Descriptor form) depending on the country variant of the system.

Note:

The ASU and Universal ASU are not supported in China.

Table 52: Australia

Balance Network Setting (CO Trunk Circuit Descriptor Form)	LS Impedance Values		
	Reference	Input	Balance
600	600	600	600
National Complex	220+820 120	220+750 145	220+820 120
TBR21	Same as Nat. Complex	Same as Nat. Complex	Same as Nat. Complex
Alternate Complex	Same as Nat. Complex	Same as Nat. Complex	Same as Nat. Complex

Table 53: Europe

Balance Network Setting (CO Trunk Circuit Descriptor Form)	LS Impedance Values	
	AC	Balance
600	270 Ω+(750 Ω 150nF)	270 Ω+(750 Ω 150nF)
National Complex	270 Ω+(750 Ω 150nF)	270 Ω+(750 Ω 150nF)
TBR21	Same as "National Complex"	Same as "National Complex"
Alternate Complex	Same as "National Complex"	Same as "National Complex"

Note:

EU countries: France, Germany, Italy, the Netherlands, Portugal, and Spain.

Table 54: New Zealand

Balance Network Setting (CO Trunk Circuit Descriptor Form)	LS Impedance Values	
	AC	Balance
600	$370 \Omega + (620 \Omega 310 \text{nF})$	$370 \Omega + (620 \Omega 310 \text{nF})$
National Complex	$370 \Omega + (620 \Omega 310 \text{nF})$	$370 \Omega + (620 \Omega 310 \text{nF})$
TBR21	Same as "National Complex"	Same as "National Complex"
Alternate Complex	Same as "National Complex"	Same as "National Complex"

Table 55: North America/Latin America

Balance Network Setting (CO Trunk Circuit Descriptor Form)	LS Impedance Values	
	AC	Balance
600	600Ω	600Ω
National Complex	600Ω	$370 \Omega + (1000 \Omega 210 \text{nF})$
TBR21	600Ω	Same as "National Complex"
Alternate Complex	600Ω	Same as "National Complex"

Note:

1. The 600 ohm setting is most often used for very short connections, such as those behind a PBX, IAD or similar device.
2. National Complex matches most unloaded central office lines. It is the most commonly used setting.
3. There is no support for loaded loops.

Table 56: United Kingdom

Balance Network Setting (CO Trunk Circuit Descriptor Form)	LS Impedance Values	
	AC	Balance
600	$370 \Omega + (620 \Omega 310 \text{nF})$	$370 \Omega + (620 \Omega 310 \text{nF})$
National Complex	$370 \Omega + (620 \Omega 310 \text{nF})$	$370 \Omega + (620 \Omega 310 \text{nF})$
TBR21	Same as "National Complex"	Same as "National Complex"
Alternate Complex	Same as "National Complex"	Same as "National Complex"

Specifications

4

This chapter contains the following sections:

- [Services Units](#)
- [Dimensions](#)
- [Power](#)
- [Telephone Power](#)
- [Hardware Interface Comparison of EX Controller with other 3300 ICP Controllers and SMB Controller](#)

Environment

Controller

Table 57: Storage Environment

Condition	Specification
Temperature	-40° to 150°F (-40° to +66°C)
Humidity	15-95% Relative Humidity, non-condensing
Vibration	0.5 g, 5 to 100 Hz, any orthogonal axis 1.5 g, 100 to 500 Hz, any orthogonal axis
Mechanical Stress	One 6 in. (15.3 cm) drop, each edge and corner adjacent to the rest face – unpackaged One 30 in. (76.2 cm) drop, each edge and corner packaged in cardboard & foam.

Table 58: Operational Environment

Condition	Specification
Temperature	40° to 122° F (4° to 50° C)
Humidity	5-95% Relative Humidity, non condensing

Condition	Specification
Maximum Heat Dissipation - fully loaded (see Note)	500 BTUs per hour (100-user) 750 BTUs per hour (250/700-user, MXe Base) 850 BTUs per hours (MXe Expanded) 170 BTUs per hour (CX II) 1020 BTUs per hour (CXi II) 1020 BTUs per hour (AX)
Air Flow	46 cubic feet per minute at maximum output of the fans 110 cubic feet per minute at maximum output (AX only)
Acoustic Emissions	Maximum 50 dBA continuous, 75 dB intermittent (<10% duty cycle)

Note:

Conversion factors: 1 watt is equal to 3.412 BTUs per hour, 1 ton of refrigeration is equal to 12,000 BTUs per hour or 3.516 Kilowatts, and 3/4 Kilowatt-hour is equal to 1 ton of refrigeration.

4.1 Services Units

Table 59: Storage Environment

Condition	Specification
Temperature	-40° to 150°F (-40° to +66°C)
Humidity	15-95% Relative Humidity, non-condensing

Condition	Specification
Vibration	0.5 g, 5 to 100 Hz, any orthogonal axis 1.5 g, 100 to 500 Hz, any orthogonal axis
Mechanical Stress	One 6 in. (15.3 cm) drop, each edge and corner adjacent to the rest face – unpackaged One 30 in. (76.2 cm) drop, each edge and corner packaged in cardboard & foam.

Table 60: Operational Environment

Condition	Specification
Temperature	40° to 122°F (4° to 50°C)
Humidity	5-95% Relative Humidity, non-condensing
Maximum Heat Dissipation - fully loaded (see Note)	170 BTUs per hour 260 BTUs per hour (ASU II only)

Note:

Conversion factors: 1 watt is equal to 3.412 BTUs per hour, 1 ton of refrigeration is equal to 12,000 BTUs per hour or 3.516 Kilowatts.

4.2 Dimensions

Controller

Table 61: Controller Dimensions

	AX	CXi II	MXe/ MXe Server
Height	12.25 in (31.1 cm) (7 U)	3.5 in. (8.9 cm) (2 U)	3.5 in. (8.9 cm) (2 U)
Width	17.76 in (45.1 cm)	17.75 in. (45.1 cm)	17.75 in. (45.1 cm)
Depth	14.6 in (37.1 cm)	16.5 in. (41.9 cm)	20.25 in. (51.4 cm)
Weight	39.68 lb (18.0 kg)	19.8 lb (8.98 kg)	33 lb (15 kg)

Note:

The controllers are 19" rack mountable.

4.2.1 Services Units

Table 62: Dimensions

	ASU, Universal ASU	ASU II
Height	1.75 in. (4.5 cm) (1 U)	3.3 in. (8.4 cm) (2 U)
Width	17.75 in. (45.1 cm) ¹	17.4 in. (44.2 cm) ¹
Depth	15.5 in. (39.4 cm)	13.3 in. (33.8 cm)

	ASU, Universal ASU	ASU II
Weight	9.4 lb. (4.3 kg) 10.6 lb. (4.8 kg) (ASU)	14.1 lb. (6.4 kg)

Note:

19" rack mountable.

4.3 Power

Controllers

Table 63: Controller Input Power Requirements

Input/disconnect	IEC320-C14, Class 1 AC, Receptacle (2 receptacles on AX and MXe with redundant power)
Input voltage/frequency rating	100-120 VAC; 50/60 Hz 200-240 VAC; 50/60 Hz
Maximum input power	100 watts (100-user) 120 watts (250-user) 150 watts (700-user) 250 watts (CXi II) 200 watts (MXe base) 250 watts (MXe expanded) 300 watts (AX)
AC source range	90-264 VAC; 47-63 Hz

4.3.1 Analog Services Units (ASU)

Table 64: ASU Input Power Requirements

Input/disconnect	IEC320-C14, Class 1 AC, Receptacle
Input voltage/frequency rating	100-120 VAC; 50/60 Hz 200-240 VAC; 50/60 Hz
Maximum input power	75 watts (ASU, Universal ASU) 125 watts (ASU II)
AC source range	90-264 VAC; 47-63 Hz
Holdover	With an input voltage of 120 VAC or 240 VAC under a full-rated load, the power supply outputs remain in regulation for a minimum of 16 ms after loss of AC mains input voltage.
Brown-Out Recovery	Recovers from an AC input brown-out or sag condition automatically.

4.4 Telephone Power

MiVoice IP Phones are capable of receiving power from a variety of sources. These include:

- Local 48 VDC power adapter that inserts power on the LAN cable spare pairs
- Power jack from a 24 VDC power adapter
- The 3300 CXi contains an internal L2 Switch that is IEEE 802.3af-compliant
- 3300 Power Dongle (not required if you are using an 802.3af-compliant version of the Cisco Catalyst 4500 switch)
- IEEE 802.3af-compliant L2 switches.

Note:

1. Refer to the Engineering Guidelines for details about a Power over Ethernet (PoE) installation.
2. 5001 IP Phones and 5005 IP Phones delivered prior to 3300 ICP Release 3.2 must be powered through the 48 VDC power adapter. Refer to the 3300 ICP Technician's Handbook for part numbers.

4.4.1 CXi II Power over Ethernet (PoE)

The CXi II has an internal Layer 2 switch that can provide 120 Watts of power to 802.3af-compliant devices according to the following general rules:

- Up to 16 IP Phones are supported.
- Up to four PKMs (PKM12 or PKM48) are supported on Dual Mode IP Phones. Only one PKM can be attached to a set. Multiple PKMs on a set require an AC adapter.
- Conference units require an AC adapter.
- Class 1, 2, and 3 devices receive 4, 7, and 13 Watts, respectively. Unclassified (Class 0) devices are budgeted 7.5 Watts by the PoE subsystem, but can receive up to 13 Watts depending on need.
- Port 1 has the highest priority, port 16 the lowest. If the power budget is exceeded, power will be turned off to the ports, starting with port 16 and ending with port 1, until less than 120 Watts is being consumed.

For information on planning PoE installation and detailed information on the CXi II IEEE 802.3af PoE capability, refer to the Engineering Guidelines.

4.4.2 3300 Power Dongle (Cisco compliant)

CAUTION:

The dongle is specifically designed to connect Mitel desktop appliances to Cisco power equipment. Do not connect equipment other than Mitel desktop appliances to the dongle.

CAUTION:

Telephone firmware must be at Release 3.2 or higher before the phone can be powered from a Cisco switch or hub through the 3300 Power Dongle. Power the set from a wall plug to update the firmware, and then connect the dongle BEFORE unplugging the phone from the wall.

CAUTION:

When power is supplied by Cisco equipment to the Mitel desktop appliance, the Ethernet cable must run directly from the Cisco equipment supplying the power to the 3300 Power Dongle (Cisco-compliant). The dongle will be directly connected to the Mitel desktop appliance.

The 3300 Power Dongle (Cisco-compliant) provides MiVoice IP Phones with LAN power from Cisco hubs that do not comply with the IEEE 802.3af Standard.

There are two versions available:

- 3300 Power Dongle (p/n 50002922) Rev1—allows MiVoice IP Phones to be powered by the Cisco 3524 and 6000 series of products or the Cisco WS-PWR-PANEL

- 3300 Power Dongle (p/n 50003734) Rev2—allows MiVoice IP Phones to be powered by the Cisco 3524, 3550, 4000 and 6000 series of products or the Cisco WS-PWR-PANEL.

The dongle provides signaling to the Cisco hub or the Cisco Power Panel to provide power on the Ethernet line.

4.4.2.1 Cisco Switches

The information in this section is believed to be accurate but is not warranted by Mitel. Please refer to Cisco documentation for specific power limits.

Cisco end-span power/data hubs include the Cisco 3524, 3550, 4000, and 6000 series of products. The Cisco WS-PWR-PANEL is a mid-span power hub. These hubs all have the capability to power the following MiVoice IP Phones: 5001 IP Phone, 5005 IP Phone, 5010 IP Phone, 5020 IP Phone, 5140 IP Appliance, 5207 IP Phone, 5215 IP Phone, 5220 IP Phone, and 5240 IP Phone.

The WS-PWR-PANEL is electrically located between a conventional data hub and the powered device. This unit passes the data pairs through from the data hub to the terminal device while inserting power on the spare pairs (4/5 and 7/8).

Before enabling port power, this unit generates a signal that a power-ready device will loop back. This signal is transmitted on the 7/8 pair and if this is looped back on the 4/5 pair, the hub then assumes a power-ready device is connected and enables power on that port. The hub continuously probes the port with signals to ensure the device is still connected. When the hub no longer detects the looped-back probing signal, it assumes the terminal device has been disconnected and disables power to that port.

The Catalyst 3524, 3550, 4000 and 6000 series products provide 48 VDC on the data pairs (1/2 and 3/6).

Before applying this voltage on its port, the Cisco hub first ensures that the attached device is capable of accepting power. It does this by transmitting a Fast Link Pulse (FLP) on one data pair while monitoring the second data pair. A power-ready device will loop back this signal to the hub via the second data pair. Once the hub senses this return signal, it ramps up voltage on the port.

Once enabled, the port continues to provide power as long as the link signal from the terminal device is present. When the signal disappears, the port interprets it as a disconnection of the terminal device and disables power to that port.

4.4.3 HP ProCurve Products

The following brief descriptions cover the HP ProCurve product used to build a VoIP solution. More detailed information can be found at the HP ProCurve Support web site, <http://www.hp.com/go/hpprocurve>. HP ProCurve 2600-PWR series and 5300 series switches can provide power to IP telephone handsets over standard CAT 5 Ethernet cable via the IEEE 802.3af Power-over-Ethernet (PoE) Standard.

Table 65: HP ProCurve Switches

Switch Series	802.3af PoE
2500	no
2600	yes
2700	no
2800	no
4000m	no
4100gl	no
6100	no
5300xl	yes
9300m	no

4.4.3.1 HP ProCurve 5300 with Expandable 10/100 PoE Modules

- Layer 2, 3, and 4 managed chassis
- 5304 provides up to 96 ports (10/100) at 15.4 W PoE
- 5308 provides up to 192 ports (10/100) at 15.4 W PoE.

4.4.3.2 HP ProCurve 2600-PWR Series

- Layer 2 and 3 managed stackable
- 2626-PWR 24 10/100 PoE ports (provides full 15.4 W to all ports)
- 2650-PWR 48 10/100 PoE ports (provides full power to all ports when connected to a 600 RPS/EPS)

4.4.3.3 HP ProCurve Redundant and External Power Supplies(600 RPS/EPS, 610 EPS)

- 600 RPS/EPS provides redundant power to any one of up to six switches
- Fully redundant PoE power for 2626-PWR for all 24 ports at 15.4 W each
- Redundant PoE power for 2650-PWR for all 48 ports at average 7.6 W each

4.5 Hardware Interface Comparison of EX Controller with other 3300 ICP Controllers and SMB Controller

The following table provides a comparison of the Hardware interface specification for an EX controller, SMB controller, and 3300 ICP Controller:

Hardware Interface Specification	FXS Card on an EX Controller	SMB Controller	ONS card on a 3300 ICP Controller
Loop feed type	Constant current	Constant current at 23 mA	Constant current at 25 mA
Operating loop limit	<ul style="list-style-type: none"> • For 4-FXS-LP: Specification at 2000 m loop length, with a total DC loop impedance = 1200 Ω max (but need to reduce to 3 REN) 	<ul style="list-style-type: none"> • Onboard FXS: 1200Ω (3REN) 	1200 Ω for 2 REN, 900 Ω for 3 REN
	<ul style="list-style-type: none"> • For non-LP 4- FXS: Specification at 450 m loop length, 600 Ω (4 REN) 	<ul style="list-style-type: none"> • FXS module: 600Ω (1REN), 300Ω (2REN) 	
DC leakage resistance	Not specified	Not specified	10 k Ω

Hardware Interface Specification	FXS Card on an EX Controller	SMB Controller	ONS card on a 3300 ICP Controller
Ring load capability	<ul style="list-style-type: none"> • For FXS-LP card: <ul style="list-style-type: none"> • 4 REN (2000 m) • 3 REN (<3000m) • For FXS card: <ul style="list-style-type: none"> • 5 REN (300 m) • 4 REN (450 m) 	<ul style="list-style-type: none"> • Onboard FXS: 3 REN (1REN = 6.8kΩ + 8.2μF) • FXS module: 2 REN (1REN = 6.8kΩ + 8.2μF) 	2 REN (equivalent to 3500 Ω in R + C combination with C not exceeding 10 μ F)
Ringing voltage open circuit	<ul style="list-style-type: none"> • For 4-FXS-LP: 60 Vrms • For non-LP 4-FXS: 45 Vrms 	<ul style="list-style-type: none"> • Onboard FXS: Operating loop limit, minimum 45Vrms • FXS module: Operating loop limit, minimum 40Vrms 	55 Vrms with 20 Vdc bias (except 63 Vrms with 10 Vdc bias for China)
Ringing range	Not specified	<ul style="list-style-type: none"> • Onboard FXS: 3 REN • FXS module: 2 REN 	Operating loop limit, minimum 40 Vrms across 2 REN load
Ringing type	Balance with DC bias, balance without DC bias, unbalance; sinusoidal or trapezoidal: Balance with DC bias, sinusoidal	<ul style="list-style-type: none"> • Onboard FXS: Balanced ringing, sinusoidal • FXS module: Balanced ringing, trapezoid 	Balanced ringing, sinusoidal
Ringing frequency	Programmable, but linked to the configured Country. Typically between 20 and 50 Hz	Programmable, but linked to the configured Country. Typically between 20 and 50 Hz	Programmable, but linked to the configured Country. Typically between 20 and 50 Hz
High Voltage Message-waiting voltage	<ul style="list-style-type: none"> • For 4-FXS-LP: 115 Vdc • For non-LP 4-FXS: 80 Vdc 	<ul style="list-style-type: none"> • Onboard FXS: 100V • FXS module: not supported 	Compatible with 90 V nominal neon lamps, (strike voltage < 110 V)
Message-waiting cadence	Supported	Supported	Fixed, nominally 500 ms on, 1.5 s off

Hardware Interface Specification	FXS Card on an EX Controller	SMB Controller	ONS card on a 3300 ICP Controller
Battery reversal	Yes, reversal is supported when Idle or when Established	Supported	Supported
Timed-flash detection	Programmable: 10 to 1200 ms	Programmable: Low Flash Timer: from 60 to 500 ms; must be left blank if type set to Caliberated. High Flash Timer: from 60 to 1500 ms. To disable the feature, set both low and high flash timers to the same value.	Programmable: Low Flash Timer: from 60 to 500 ms; must be left blank if type set to Caliberated. High Flash Timer: from 60 to 1500 ms. To disable the feature, set both low and high flash timers to the same value.
Dial-pulse detection	Not supported	Not supported	Not supported
Metering generation	Not supported	Not supported	Not supported
Earth recall detection	Not specified	Not supported	Not supported
Ground start detection	Not supported	Not supported	Not supported
Positive disconnect	supported	supported	Programmable between 250 and 1000 ms, current feed < 1 mA

Hardware Interface Specification	FXS Card on an EX Controller	SMB Controller	ONS card on a 3300 ICP Controller
Off-hook threshold from idle	11 mA	11 mA	AMB: 3.5mA ASU2: 12mA AX Line cards: 3.5mA by default; 12mA for phones that draw more than 3.5mA while idle (increases overall power consumption).
Off-hook from voltage message waiting	21 mA	21 mA	20 mA
Off-hook threshold from ring	21 mA	21 mA	Not specified

Appendix A : Signaling, Tones, and Transmission

5

This chapter contains the following sections:

- [Time-Out Information](#)
- [Transmission Characteristics](#)
- [Loss Plan Matrices](#)
- [Tone Plans](#)

Signaling and Supervisory Tones

The standard range of programmed tones are composed of

- 12 DTMF sets of tones
- 1 set of tones that form part of the call progress tone plan
- 1 test of 1004 Hz (digital milliwatt).

5.1 Time-Out Information

The system is capable of responding to or providing the following supervisory conditions:

- Switchhook flashes having a duration of between 160 ms and 1500 ms (as programmed) to activate Transfer/Consultation/Hold/Add-On features.
- Call transfer dial tone can be obtained by generating a calibrated flash. This method is recognized internationally and is generated in one of three ways:
 - use a flash-hook for telephones connected to ONS circuits
 - use the calibrated flash button (for equipped telephones)
- Station switchhook flashes of less than the maximum programmed switchhook flash time will not be repeated towards the central office.
- An open Tip lead condition of 500 ms (optional 100 ms) or longer duration on a CO trunk will release the system connection.
- Momentary open loop conditions of up to 350 ms (optional 100 ms) generated by the central office on outgoing system calls will not release calls.
- Station on-hook conditions will release a trunk connection after the selected maximum time.

Table 66: Time-Out Information

Feature	Time-Out Period	Description
No Answer Recall Timer	0 - 125 s	If there is no answer at the extension after the time-out expires, it will ring back at the attendant console or transfer station.
Camp-On Recall Timer	0 - 180 s	Incoming calls camp-on to a busy station before being returned to the attendant, if not answered before time-out expires.
Call Hold Timer	10 - 600 s	Calls placed on hold ring back to the station user upon expiry.
Attendant Busyout Timer	1 - 1440 min	System switches to night service if there is no activity at the attendant console after calls are received.
First Digit Timer	5 - 60 s	This is the time the system will wait for the first digit after going off-hook at a station.
Interdigit Timer	3 - 60 s	Time between dialed digits.
Delay Ring Timer	5 - 60 s	Time before line rings on key set.
Callback Cancel Timer	1 - 24 hrs	Time after which callback functions are reset and cleared or cancelled.
Call Forward - No Answer Timer	0 - 125 s	Length of time a station rings before the call is forwarded or rerouted.

Feature	Time-Out Period	Description
Switchhook Flash	60 - 1500 ms	Length of time that a switch-hook can be flashed without dropping the trunk or line.
Ringling Timer	60 - 300 s	The length of time a station rings another station before the call is terminated.

5.2 Transmission Characteristics

The transmission characteristics of all country variants of the 3300 ICP and ancillary subsystems comply with the specifications listed in [Table 40: Supported Transmission Standards](#) on page 62.

5.2.1 Compliances

MiVoice Digital Phones meet the requirements of:

- ANSI/TIA/EIA-810-A “Transmission Requirements for Narrowband Voice over IP and Voice over PCM Digital Wireline Telephones”

In addition, the 3300 ICP meets all local specifications for each Mitel business region.

5.2.2 Line and Trunk Support Characteristics (North America)

The North American variant of the system supports the following line and trunk parameters:

- Station Loop - The industry standard station loop range, including the station apparatus, can be up to a maximum of 600 ohms (ONS Line).
- CO Trunk Loop - The system operates with CO Trunks up to a maximum of 1600 ohms loop resistance.
- CO Trunk Seizure - The nominal seizure resistance
 - for AMB/AOB V1 trunks: 320 ohms at 20 mA
 - for AMB/AOB v2/v3, ASU II and AX trunks: 370 ohms at 20 mA
- CO Trunk Resistance - The on-hook DC input resistance of the LS trunks is not less than 5M ohms.

5.3 Loss Plan Matrices

Each country has stipulated requirements concerning acceptable transmission performance for telephone systems. The loss plan matrices provide the correct electrical losses in decibels (dB) for each connection to meet the specified requirement.

Loss plans have a direct effect on the acoustic levels provided at the set. Part of meeting the requirements is to identify the reference set requirements for all standard and proprietary sets to be used in each country. It is generally desirable to achieve the same relative loudness levels for all standard and proprietary telephones for a specified loss plan, taking into account: loop lengths, transmission format (analog or digital), different transducers in use, line/trunk impedances, and terminating impedances. In the loss plans, positive values are losses and negative values are gains. The losses are shown in one direction only (outgoing, from the specified port type); the reverse path loss can be found by using a second look-up.

Note:

1. MiVoice IP Phones meet the following ITU-T recommended loudness rating: - Send Loudness Rating (SLR) 8 dB - Receive Loudness Rating (RLR) 2 dB.

5.3.1 Port Abbreviations

[Table 67: Port Abbreviations](#) lists the Mitel Loss Plan, TIA, and ETSI abbreviations for each port. The Mitel Loss Plan abbreviation is used in the Loss Plan Matrices.

Table 67: Port Abbreviations

Port Name	Abbreviation		
	Mitel Loss Plan	TIA	ETSI
IP ONS On-Premise Station	iONS	ONS	L21
On-Premise Station	ONS	ONS	L21
IP Off-Premise Station	iOPS	OPS	L22
Off-Premise Station	ONS	C	L22

Port Name	Abbreviation		
	Mitel Loss Plan	TIA	ETSI
Digital Station	DGS	DGS	LD
Wide Area Network	WAN	WAN	WAN
Digital CO Trunk	DCO	DAL	KD
IP Analog CO Trunk	iACO	FXO	K2
IP Analog CO Trunk (short)	iACOs	FXD	K2s
Analog CO Trunk	ACO	AAL(A)	K2
Analog CO Trunk (short)	ACOs	AAL(D)	K2s
Analog Tie Trunk	ATT	ATT	M2/M4
Analog Board ONS On-Premise Station	abONS	ONS	L21
Analog Board Analog CO Trunk	abACO	FXO	K2
Analog Board Analog CO Trunk (short)	abACOs	FXD	K2s
Analog Board Analog CO Trunk Extra Long	abACOhl	N/A	N/A

Note:

iONS, iOPS, iACO, and iACOs apply to the new analog interface designs that comply with the IP-connected half-channel loss plan.

5.3.1.1 Station Circuits

The following table lists station circuits, their software and loss plan abbreviations, and the hardware device that is used to support a particular station circuit.

Table 68: Station Circuits

Station Circuit	Abbreviation		Supporting Hardware
	Software	Mitel Loss Plan	
ASU On-Premise Station	iONS	iONS	Analog Services Unit
ASU II On-Premise Station	abONS	abONS	Analog Services Unit II, AX
IP	WAN	WAN	3300 ICP Ethernet Ports
SX-2000 On-Premise Station	ONS	ONS	SX-2000 ONS Cards
SX-2000 Off-Premise Station	C	ONS	SX-2000 OPS Cards
SX-2000 Digital Set	DGS	SS400	SX-2000 DNIC Cards

Protected ONS ports (ONSP) are available on:

- The ONS/LS combo card (can be used the ASU-II and the AX)
- The 16 port ONS card (can be used the ASU-II and the AX)
- ports 1 and 2 on the CXi II Controller and MXe Controller (PN 50005090) with AMB Version III

The ONSP ports are suitable for off-premise applications, and meet the requirements of 60950-01 and IEC 55024, regular ONS ports are intended for on-premise applications only.

ONSP ports utilize the same loss plan setting as regular ONS ports

5.3.1.2 Trunk Circuits

The following table lists trunk circuits, software and loss plan abbreviations, and the hardware device that is used to support a particular trunk circuit.

Table 69: Trunk Circuits

Trunk Circuit	Abbreviation		Supporting Hardware
	Software	Mitel Loss Plan	
IP	WAN	WAN	3300 ICP Ethernet Ports
Analog Board Analog CO Trunk	abACO	abACO	Analog Main Board and Analog Option Board
Analog Board Analog CO Trunk Short	abACO(s)	abACOs	Analog Main Board and Analog Option Board
Analog Board Analog CO Trunk Extra Long	abACOhl	abACOhl	Analog Main Board and Analog Option Board
ASU Loop Start Trunk	iACO	iACO	ASU
ASU Loop Start Short Trunk	iACO(s)	iACOs	ASU
ASU IICO Trunk	abACO	abACO	ASU II and AX
ASU II CO Trunk Short	abACO(s)	abACOs	ASU II and AX
ASU II CO Trunk Extra Long	abACOhl	abACOhl	ASU II and AX
ISDN Trunks	ISDN	DCO	BRI NSU

Trunk Circuit	Abbreviation		Supporting Hardware
	Software	Mitel Loss Plan	
DS1 A-law Digital Tie Trunk	DTT(DU)	DCO	Universal NSU
DS1 μ -law Digital Tie Trunk	DTT(DU)	DCO	Universal NSU

The Loss Plan Matrices for countries supported by the 3300 ICP are provided in the following section. The values in these tables are in decibels (dB) and represent the voice path loss from a particular port to a particular port.

Note:

These matrices are loss plans, so a positive number represents a loss and a negative number represents a gain.

To determine the port-to-port loss for a given connection:

1. Look up the first port in the Port column on the left side of the applicable Loss Plan Matrix.
2. Follow this row across to the second port's column.

For example, to determine the loss for an abONS to abACOs connection in Australia, find the abONS row and then follow the row to the abACOs column. The port-to-port loss is 1 dB.

5.3.1.3 Australia

Port		iONS	ONS	iOPS	OPS	DGS	WAN	DCO
	Loss	↑	↑	↑	↑	↑	↑	↑
iONS	→	11	11	8	8	3	3	2
ONS	→	11	11	8	8	3	3	2
iOPS	→	8	8	5	5	0	0	-1
OPS	→	8	8	5	5	0	0	-1
DGS	→	8	8	5	5	0	0	0
WAN	→	8	8	5	5	0	0	0
DCO	→	8	8	5	5	0	0	0
iACO	→	0	0	-3	-3	-6	-5	-6
iACOs	→	1	1	-2	-2	-6	-6	-6

Port		iONS	ONS	iOPS	OPS	DGS	WAN	DCO
ACO	→	0	0	-3	-3	-6	-6	-6
ACOs	→	1	1	-2	-2	-6	-6	-6
ATT	→	7	7	4	4	0	0	0
abONS	→	11	11	8	8	3	3	2
abACO	→	0	0	-3	-3	-6	-5	-6
abACOs	→	1	1	-2	-2	-6	-6	-6
abACOhl	→	-2	-2	-5	-5	-9	-9	-9

iACO	iACOs	ACO	ACOs	ATT	abONS	abACO	abACOs	abA COhl
↑	↑	↑	↑	↑	↑	↑	↑	↑
0	1	1	1	2	11	0	1	0
0	1	1	1	2	11	0	1	0
-2	-2	-1	-1	-1	8	-2	-2	-2
-2	-2	-1	-1	-1	8	-2	-2	-2
-1	0	0	1	0	8	-1	0	-1
-1	0	0	1	0	8	-1	0	0
-1	0	0	0	0	8	-1	0	-1
-4	-4	-4	-4	-6	0	-4	-4	-4
-4	-4	-4	-4	-6	1	-4	-4	-4
-4	-4	-4	-4	-6	0	-4	-4	-4
-4	-4	-4	-4	-6	1	-4	-4	-4
0	0	0	0	0	7	0	0	0
0	1	1	1	2	11	0	1	0
-4	-4	-4	-4	-6	0	-4	-4	-4
-4	-4	-4	-4	-6	1	-4	-4	-4
-4	-4	-4	-4	-6	-2	-4	-4	-4

5.3.1.4 Brazil

Port		iONS	ONS	iOPS	OPS	DGS	WAN	DCO
	Loss	↑	↑	↑	↑	↑	↑	↑
iONS	→	6	6	3	3	0	0	0
ONS	→	6	6	3	3	0	0	0
iOPS	→	3	3	0	0	0	0	0
OPS	→	3	3	0	0	0	0	0
DGS	→	9	9	6	6	0	0	0
WAN	→	9	9	6	6	0	0	0

Port		iONS	ONS	iOPS	OPS	DGS	WAN	DCO
DCO	→	7	7	6	6	0	0	0
iACO	→	1	1	0	0	-6	-6	-6
iACOs	→	1	1	0	0	-3	-3	-6
ACO	→	1	1	0	0	-6	-6	-3
ACOs	→	1	1	0	0	-3	-3	-3
ATT	→	3	3	0	0	0	0	0
abONS	→	6	6	3	3	0	0	0
abACO	→	1	1	0	0	-6	-6	-6
abACOs	→	1	1	0	0	-3	-3	-6
abACOhl	→	-2	-2	-3	-3	-9	-9	-9

iACO	iACOs	ACO	ACOs	ATT	abONS	abACO	abACOs	abA COhl
↑	↑	↑	↑	↑	↑	↑	↑	↑
1	1	1	1	3	6	1	1	1
1	1	1	1	3	6	1	1	1
0	0	0	0	3	3	0	0	0
0	0	0	0	3	3	0	0	0
0	3	0	3	3	9	0	3	0
0	3	0	3	3	9	0	3	0
1	1	0	3	3	7	1	1	0
0	0	0	0	0	1	0	0	0
0	0	0	0	0	1	0	0	0
0	0	0	0	0	1	0	0	0
0	0	0	0	0	1	0	0	0
0	0	0	0	0	3	0	0	0
1	1	1	1	3	6	1	1	1
0	0	0	0	0	1	0	0	0
0	0	0	0	0	1	0	0	0
0	0	0	0	0	-2	0	0	0

5.3.1.5 China

Port		iONS	ONS	OPS	DGS	WAN	DCO
	Loss	↑	↑	↑	↑	↑	↑
iONS	→	10	10	7	3	3	3
ONS	→	10	10	7	3	3	3
OPS	→	7	7	4	0	0	0

Port		iONS	ONS	OPS	DGS	WAN	DCO
DGS	→	7	7	4	0	0	0
WAN	→	7	7	4	0	0	0
DCO	→	7	7	4	0	0	0
iACO	→	7	7	4	0	0	0
iACOs	→	7	7	4	0	0	0
ACO	→	7	7	4	0	0	0
ACOs	→	7	7	4	0	0	0
ATT	→	7	7	4	0	0	0
abONS	→	10	10	7	3	3	3
abACO	→	7	7	4	0	0	0
abACOs	→	7	7	4	0	0	0
abACOhl	→	4	4	1	-3	-3	-3

iACO	iACOs	ACO	ACOs	ATT	abONS	abACO	abACOs	abAC Ohl
↑	↑	↑	↑	↑	↑	↑	↑	↑
6	7	6	7	1	10	6	7	6
6	7	6	7	1	10	6	7	6
3	4	3	4	-2	7	3	4	3
3	4	3	4	-2	7	3	4	3
3	4	3	4	-2	7	3	4	3
3	4	3	4	-2	7	3	4	3
3	4	3	4	-4	7	3	4	3
3	4	3	4	-2	7	3	4	3
3	4	3	4	-4	7	3	4	3
3	4	3	4	-2	7	3	4	3
3	4	3	4	-3	7	3	4	3
6	7	6	7	1	10	6	7	6
3	4	3	4	-4	7	3	4	3
3	4	3	4	-2	7	3	4	3
3	4	3	4	-4	4	3	4	3

5.3.1.6 France

Port		iONS	ONS	OPS	DGS	WAN	DCO	iACO
	Loss	↑	↑	↑	↑	↑	↑	↑
iONS	→	10	10	7	3	3	3	6
ONS	→	10	10	7	3	3	3	6

Port		iONS	ONS	OPS	DGS	WAN	DCO	iACO
OPS	→	7	7	4	0	0	0	3
DGS	→	7	7	4	0	0	0	3
WAN	→	7	7	4	0	0	0	3
DCO	→	7	7	4	0	0	0	3
iACO	→	7	7	4	0	0	0	3
iACOs	→	7	7	4	0	0	0	3
ACO	→	7	7	4	0	0	0	3
ACOs	→	7	7	4	0	0	0	3
ATT	→	7	7	4	0	0	0	3
abONS	→	10	10	7	3	3	3	6
abACO	→	7	7	4	0	0	0	3
abACOs	→	7	7	4	0	0	0	3
abACOhl	→	4	4	1	-3	-3	-3	3

iACOs	ACO	ACOs	ATT	abONS	abACO	abACOs	abACOhl
↑	↑	↑	↑	↑	↑	↑	↑
7	6	7	1	10	6	7	6
7	6	7	1	10	6	7	6
4	3	4	-2	7	3	4	3
4	3	4	-2	7	3	4	3
4	3	4	-2	7	3	4	3
4	3	4	-2	7	3	4	3
4	3	4	-4	7	3	4	3
4	3	4	-2	7	3	4	3
4	3	4	-4	7	3	4	3
4	3	4	-2	7	3	4	3
4	3	4	-3	7	3	4	3
7	6	7	1	10	6	7	6
4	3	4	-4	7	3	4	3
4	3	4	-2	7	3	4	3
4	3	4	-4	4	3	4	3

5.3.1.7 Germany

Port		iONS	ONS	OPS	DGS	WAN	DCO	iACO
	Loss	↑	↑	↑	↑	↑	↑	↑
iONS	→	15	15	12	5	5	5	4
ONS	→	15	15	10	3	3	3	4

Port		iONS	ONS	OPS	DGS	WAN	DCO	iACO
OPS	→	12	12	7	0	0	0	1
DGS	→	10	10	7	0	0	0	-1
WAN	→	10	10	7	0	0	0	-1
DCO	→	10	10	7	0	0	0	-1
iACO	→	4	4	1	-5	-5	-6	-5
iACOs	→	6	6	3	-4	-4	-4	-5
ACO	→	4	4	1	-6	-6	-6	-5
ACOs	→	6	6	2	-5	-5	-5	-5
ATT	→	8	8	5	-2	-2	-2	-3
abONS	→	15	15	12	5	5	5	4
abACO	→	4	4	1	-6	-5	-6	-5
abACOs	→	6	6	3	-4	-4	-4	-5
abACOhl	→	1	1	-2	-9	-8	-9	-5

iACOs	ACO	ACOs	ATT	abONS	abACO	abACOs	abACOhl
↑	↑	↑	↑	↑	↑	↑	↑
6	4	6	3	15	4	6	4
6	4	6	3	15	4	6	4
3	1	3	0	12	1	3	1
1	0	1	0	10	-1	1	-1
1	0	1	0	10	-1	1	-1
1	0	1	0	10	-1	1	-1
-5	-5	-5	-7	4	-5	-5	-5
-3	-5	-3	-6	6	-5	-3	-5
-5	-5	-5	-7	4	-5	-5	-5
-3	-5	-3	-6	6	-5	-3	-5
-1	-3	-1	-4	8	-3	-1	-3
6	4	6	3	15	4	6	4
-5	-5	-5	-6	4	-5	-5	-5
-3	-5	-3	-6	6	-5	-3	-5
-5	-5	-5	-6	1	-5	-5	-5

5.3.1.8 Italy

Port		iONS	ONS	OPS	DGS	WAN	DCO	iACO
	Loss	↑	↑	↑	↑	↑	↑	↑
iONS	→	15	15	12	5	5	5	4
ONS	→	15	13	12	3	3	3	4

Port		iONS	ONS	OPS	DGS	WAN	DCO	iACO
OPS	→	12	12	9	2	2	2	1
DGS	→	10	10	7	0	0	0	-1
WAN	→	10	10	7	0	0	0	-1
DCO	→	10	10	7	0	0	0	-1
iACO	→	4	4	1	-5	-5	-6	-5
iACOs	→	6	6	3	-4	-4	-4	-5
ACO	→	4	4	1	-3	-3	-3	-3
ACOs	→	6	6	3	-3	-3	-3	-4
ATT	→	8	8	5	-2	-2	-2	-2
abONS	→	15	15	12	5	5	5	4
abACO	→	4	4	1	-6	-5	-6	-5
abACOs	→	6	6	3	-4	-4	-4	-5
abACOhl	→	1	1	-2	-9	-8	-9	-5

iACOs	ACO	ACOs	ATT	abONS	abACO	abACOs	abACOhl
↑	↑	↑	↑	↑	↑	↑	↑
6	4	6	3	15	4	6	4
6	4	6	3	15	4	6	4
3	1	3	0	12	1	3	1
1	-1	1	-2	10	-1	1	-1
1	-1	1	-2	10	-1	1	-1
1	-1	1	-2	10	-1	1	-1
-5	-7	-5	-8	4	-5	-5	-5
-3	-5	-3	-6	6	-5	-3	-5
-5	-5	-5	-6	4	-4	-4	-4
-3	-5	-3	-6	6	-4	-3	-4
-1	-3	-1	-4	8	-3	-1	-3
6	4	6	3	15	4	6	4
-5	-6	-5	-7	4	-5	-5	-5
-3	-5	-3	-6	6	-5	-3	-5
-5	-6	-5	-7	1	-5	-5	-5

5.3.1.9 Latin America

Port		iONS	ONS	OPS	DGS	WAN	DCO	iACO
	Loss	↑	↑	↑	↑	↑	↑	↑
iONS	→	6	6	3	0	0	0	0
ONS	→	6	6	3	0	0	0	0

Port		iONS	ONS	OPS	DGS	WAN	DCO	iACO
OPS	→	3	3	0	0	0	0	0
DGS	→	9	9	6	0	0	0	0
WAN	→	9	9	6	0	0	0	0
DCO	→	9	9	6	0	0	0	0
iACO	→	0	0	0	-6	-6	-6	0
iACOs	→	3	3	0	-3	-3	-3	0
ACO	→	0	0	0	-6	-3	-3	0
ACOs	→	3	3	0	-3	-3	-3	0
ATT	→	3	3	0	0	0	0	0
abONS	→	6	6	3	0	0	0	0
abACO	→	0	0	0	-6	-6	-6	0
abACOs	→	3	3	0	-3	-3	-3	0
abACOhl	→	-3	-3	-3	-9	-9	-9	0

iACOs	ACO	ACOs	ATT	abONS	abACO	abACOs	abACOhl
↑	↑	↑	↑	↑	↑	↑	↑
3	0	3	3	6	0	3	0
3	0	3	3	6	0	3	0
0	0	0	3	3	0	0	0
3	0	3	3	9	0	3	0
3	0	3	3	9	0	3	0
3	0	3	3	9	0	3	0
0	0	0	0	0	0	0	0
0	0	0	0	3	0	0	0
0	0	0	0	0	0	0	0
0	0	0	0	3	0	0	0
0	0	0	0	3	0	0	0
3	0	3	3	6	0	3	0
0	0	0	0	0	0	0	0
0	0	0	0	3	0	0	0
0	0	0	0	-3	0	0	0

5.3.1.10 The Netherlands

Port		iONS	ONS	OPS	DGS	WAN	DCO	iACO
	Loss	↑	↑	↑	↑	↑	↑	↑
iONS	→	15	15	12	5	5	5	4
ONS	→	15	15	10	3	3	3	4

Port		iONS	ONS	OPS	DGS	WAN	DCO	iACO
OPS	→	12	12	7	0	0	0	1
DGS	→	10	10	7	0	0	0	-1
WAN	→	10	10	7	0	0	0	-1
DCO	→	10	10	7	0	0	0	-1
iACO	→	4	4	1	-5	-5	-6	-5
iACOs	→	6	6	3	-4	-4	-4	-5
ACO	→	4	4	1	-6	-6	-6	-5
ACOs	→	6	6	2	-5	-5	-5	-5
ATT	→	8	8	5	-2	-2	-2	-3
abONS	→	15	15	12	5	5	5	4
abACO	→	4	4	1	-6	-5	-6	-5
abACOs	→	6	6	3	-4	-4	-4	-5
abACOhl	→	1	1	-2	-9	-8	-9	-5

iACOs	ACO	ACOs	ATT	abONS	abACO	abACOs	abACOhl
↑	↑	↑	↑	↑	↑	↑	↑
6	4	6	3	15	4	6	4
6	4	6	3	15	4	6	4
3	1	3	0	12	1	3	1
1	0	1	0	10	-1	1	-1
1	0	1	0	10	-1	1	-1
1	0	1	0	10	-1	1	-1
-5	-5	-5	-7	4	-5	-5	-5
-3	-5	-3	-6	6	-5	-3	-5
-5	-5	-5	-7	4	-5	-5	-5
-3	-5	-3	-6	6	-5	-3	-5
-1	-3	-1	-4	8	-3	-1	-3
6	4	6	3	15	4	6	4
-5	-5	-5	-6	4	-5	-5	-5
-3	-5	-3	-6	6	-5	-3	-5
-5	-5	-5	-6	1	-5	-5	-5

5.3.1.11 New Zealand

Port		iONS	ONS	OPS	DGS	WAN	DCO	iACO
	Loss	↑	↑	↑	↑	↑	↑	↑
iONS	→	11	11	8	3	3	3	0

Port		iONS	ONS	OPS	DGS	WAN	DCO	iACO
ONS	→	11	11	8	3	3	3	0
OPS	→	8	8	5	0	0	0	-3
DGS	→	8	8	5	0	0	0	-2
WAN	→	8	8	5	0	0	0	0
DCO	→	8	8	5	0	0	0	-2
iACO	→	0	0	-3	-8	-6	-8	-4
iACOs	→	2	2	-1	-6	-6	-6	-4
ACO	→	0	0	-1	-3	-3	-3	-4
ACOs	→	2	2	-1	-3	-3	-3	-4
ATT	→	10	10	7	4	4	4	2
abONS	→	11	11	8	3	3	3	0
abACO	→	0	0	-3	-8	-6	-8	-4
abACOs	→	2	2	-1	-6	-6	-6	-4
abACOhl	→	-3	-3	-6	-10	-8	-10	-4

iACOs	ACO	ACOs	ATT	abONS	abACO	abACOs	abACOhl
↑	↑	↑	↑	↑	↑	↑	↑
2	0	2	-1	11	0	2	0
2	0	2	-1	11	0	2	0
-1	-3	-1	-4	8	-3	-1	-3
0	0	0	-2	8	-2	0	-2
0	0	0	-2	8	0	0	0
0	0	0	-1	8	-2	0	-2
-4	-5	-4	-9	0	-5	-4	-5
-4	-5	-4	-8	2	-5	-4	-5
-4	-4	-4	-6	0	-4	-4	-4
-4	-5	-4	-6	2	-4	-4	-4
3	5	5	2	10	2	3	2
2	0	2	-1	11	0	2	0
-4	-5	-4	-9	0	-4	-4	-4
-4	-5	-4	-8	2	-4	-4	-4
-4	-5	-4	-9	-3	-4	-4	-4

5.3.1.12 North America

Port		iONS	ONS	OPS	DGS	WAN	DCO
	Loss	↑	↑	↑	↑	↑	↑
iONS	→	6	6	3	0	0	0

Port		iONS	ONS	OPS	DGS	WAN	DCO
ONS	→	6	6	3	0	0	0
OPS	→	3	3	0	0	0	0
DGS	→	9	9	6	0	0	0
WAN	→	9	9	6	0	0	0
DCO	→	9	9	6	0	0	0
iACO	→	0	0	0	-6	-6	-6
iACOs	→	3	3	0	-3	-3	-3
ACO	→	0	0	0	-6	-3	-3
ACOs	→	3	3	0	-3	-3	-3
ATT	→	3	3	0	0	0	0
abONS	→	6	6	3	0	0	0
abACO	→	0	0	0	-6	-6	-6
abACOs	→	3	3	0	-3	-3	-3
abACOhl	→	-3	-3	-3	-9	-9	-9

iACO	iACOs	ACO	ACOs	ATT	abONS	abACO
↑	↑	↑	↑	↑	↑	↑
0	3	0	3	3	6	0
0	3	0	3	3	6	0
0	0	0	0	3	3	0
0	3	0	3	3	9	0
0	3	0	3	3	9	0
0	3	0	3	3	9	0
0	0	0	0	0	0	0
0	0	0	0	0	3	0
0	0	0	0	0	0	0
0	0	0	0	0	3	0
0	0	0	0	0	3	0
0	3	0	3	3	6	0
0	0	0	0	0	0	0
0	0	0	0	0	3	0
0	0	0	0	0	-3	0

5.3.1.13 Portugal

Port		iONS	ONS	OPS	DGS	WAN	DCO	iACO
	Loss	↑	↑	↑	↑	↑	↑	↑
iONS	→	15	15	12	5	5	5	4

Port		iONS	ONS	OPS	DGS	WAN	DCO	iACO
ONS	→	15	15	10	3	3	3	4
OPS	→	12	12	7	0	0	0	1
DGS	→	10	10	7	0	0	0	-1
WAN	→	10	10	7	0	0	0	-1
DCO	→	10	10	7	0	0	0	-1
iACO	→	4	4	1	-5	-5	-6	-5
iACOs	→	6	6	3	-4	-4	-4	-5
ACO	→	4	4	1	-6	-6	-6	-5
ACOs	→	6	6	2	-5	-5	-5	-5
ATT	→	8	8	5	-2	-2	-2	-3
abONS	→	15	15	12	5	5	5	4
abACO	→	4	4	1	-6	-5	-6	-5
abACOs	→	6	6	3	-4	-4	-4	-5
abACOhl	→	1	1	-2	-9	-8	-9	-5

iACOs	ACO	ACOs	ATT	abONS	abACO	abACOs	abACOhl
↑	↑	↑	↑	↑	↑	↑	↑
6	4	6	3	15	4	6	4
6	4	6	3	15	4	6	4
3	1	3	0	12	1	3	1
1	0	1	0	10	-1	1	-1
1	0	1	0	10	-1	1	-1
1	0	1	0	10	-1	1	-1
-5	-5	-5	-7	4	-5	-5	-5
-3	-5	-3	-6	6	-5	-3	-5
-5	-5	-5	-7	4	-5	-5	-5
-3	-5	-3	-6	6	-5	-3	-5
-1	-3	-1	-4	8	-3	-1	-3
6	4	6	3	15	4	6	4
-5	-5	-5	-6	4	-5	-5	-5
-3	-5	-3	-6	6	-5	-3	-5
-5	-5	-5	-6	1	-5	-5	-5

5.3.1.14 Spain

Port		iONS	ONS	OPS	DGS	WAN	DCO	iACO
	Loss	↑	↑	↑	↑	↑	↑	↑
iONS	→	15	15	12	5	5	5	4

Port		iONS	ONS	OPS	DGS	WAN	DCO	iACO
ONS	→	15	15	10	3	3	3	4
OPS	→	12	12	7	0	0	0	1
DGS	→	10	10	7	0	0	0	-1
WAN	→	10	10	7	0	0	0	-1
DCO	→	10	10	7	0	0	0	-1
iACO	→	4	4	1	-5	-5	-6	-5
iACOs	→	6	6	3	-4	-4	-4	-5
ACO	→	4	4	1	-6	-6	-6	-5
ACOs	→	6	6	2	-5	-5	-5	-5
ATT	→	8	8	5	-2	-2	-2	-3
abONS	→	15	15	12	5	5	5	4
abACO	→	4	4	1	-6	-5	-6	-5
abACOs	→	6	6	3	-4	-4	-4	-5
abACOhl	→	1	1	-2	-9	-8	-9	-5

iACOs	ACO	ACOs	ATT	abONS	abACO	abACOs	abACOhl
↑	↑	↑	↑	↑	↑	↑	↑
6	4	6	3	15	4	6	4
6	4	6	3	15	4	6	4
3	1	3	0	12	1	3	1
1	0	1	0	10	-1	1	-1
1	0	1	0	10	-1	1	-1
1	0	1	0	10	-1	1	-1
-5	-5	-5	-7	4	-5	-5	-5
-3	-5	-3	-6	6	-5	-3	-5
-5	-5	-5	-7	4	-5	-5	-5
-3	-5	-3	-6	6	-5	-3	-5
-1	-3	-1	-4	8	-3	-1	-3
6	4	6	3	15	4	6	4
-5	-5	-5	-6	4	-5	-5	-5
-3	-5	-3	-6	6	-5	-3	-5
-5	-5	-5	-6	1	-5	-5	-5

5.3.1.15 United Kingdom

Port		iONS	ONS	OPS	DGS	WAN	DCO	iACO
	Loss	↑	↑	↑	↑	↑	↑	↑

Port		iONS	ONS	OPS	DGS	WAN	DCO	iACO
iONS	→	15	15	12	5	5	5	4
ONS	→	15	15	12	5	5	5	4
OPS	→	12	10	9	2	2	2	1
DGS	→	10	8	7	0	0	0	-1
WAN	→	10	8	7	0	0	0	-1
DCO	→	10	8	7	0	0	0	-1
iACO	→	4	4	1	-5	-5	-6	-5
iACOs	→	5	5	2	-5	-5	-5	-6
ACO	→	4	4	1	-6	-3	-3	-5
ACOs	→	5	5	2	-5	-3	-3	-5
ATT	→	8	8	5	-2	-2	-2	-3
abONS	→	15	15	12	5	5	5	4
abACO	→	4	4	1	-6	-5	-6	-5
abACOs	→	5	5	2	-5	-5	-5	-6
abACOhl	→	1	1	-2	-9	-9	-9	-5

iACOs	ACO	ACOs	ATT	abONS	abACO	abACOs	abACOhl
↑	↑	↑	↑	↑	↑	↑	↑
5	4	5	3	15	4	5	4
5	4	5	3	15	4	5	4
2	1	2	0	12	1	2	1
0	-1	0	-2	10	-1	0	-1
0	-1	0	-2	10	-1	0	-1
0	-1	0	-2	10	-1	0	-1
-4	-5	-5	-7	4	-5	-4	-5
-5	-5	-5	-7	5	-6	-5	-6
-5	-5	-5	-6	4	-5	-5	-5
-5	-5	-5	-6	5	-5	-5	-5
-2	-3	-2	-4	8	-3	-2	-3
5	4	5	3	15	4	5	4
-4	-5	-5	-7	4	-5	-6	-5
-5	-5	-5	-7	5	-4	-5	-4
-4	-5	-5	-7	1	-5	-6	-5

5.4 Tone Plans

Tone plans permit the station user to distinguish different stages of call progress and different types of calls. Each tone is assigned a level which ensures an acceptable quality.

i Note:

1. DTMF tones are supported.
2. Digital (DGS) and IP (WAN) tones are conveyed as Real-Time Transfer Protocol (RTP) packets.
3. This interface is not supported in this country.

5.4.1 Australia

Tone Plan

Tone	Frequency (Hz)	Cadence (s)
ARS 2nd Dial	400/425	Continuous
Busy	425	0.375 on, 0.375 off, repeat
Camp-on	425	0.25 on, off
Conference	425	0.8 on, off
Confirmation	400/425	0.1 on, 0.1 off, 0.1 on, 0.7 off, repeat
Dial Tone	400/425	Continuous
Feature Active Dial	400/425	(0.95 on, 0.05 off) x 2, then (0.1 on, 0.1 off, 0.1 on, 0.7 off, repeat for ever)
Interrupted Dial	400/425	(0.95 on, 0.05 off) x 2, then (0.1 on, 0.1 off, 0.1 on, 0.7 off, repeat for ever)
Message Notification	400/425	(0.95 on, 0.05 off) x 2, then (0.1 on, 0.1 off, 0.1 on, 0.7 off, repeat for ever)
Modem Answer	2025	0.95 on, 0.05 off, repeat
Override	1400	0.2 on, off
Paging	425	0.25 on, off
Reorder	425	2.5 on, 0.5 off, repeat
Ringback	400/450	0.4 on, 0.2 off, 0.4 on, 2 off, repeat
Special Busy	425	0.375 on, 0.375 off, repeat
Special Ringback	400/450	1.0 on, 2.0 off, repeat
Transfer Dial	400/425	(0.1 on, 0.1 off) x 3, then continuous

Tone	Frequency (Hz)	Cadence (s)
Voice Mail	440	0.6 on, off

Tone	Output Level (in dBm)									
	iONS abO NS	ONS	iOPS	OPS	iACO abA CO a bACO hl	iACO s ab ACOs	ACO	ACOs	DCO	ATT
ARS 2nd Dial	-15	-15	---	---	-10	-13	-10	-10	-8	-12
Busy	-15	-15	---	---	-10	-13	-10	-10	-8	-12
Dial	-15	-15	---	---	-10	-13	-10	-10	-8	-12
Camp- on	-15	-15	---	---	-10	-13	-10	-10	-8	-12
Conf erence	-15	-15	---	---	-10	-13	-10	-10	-8	-12
Conf irmation	-15	-15	---	---	-10	-13	-10	-10	-8	-12
Feat ure Acti ve Dial	-15	-15	---	---	-10	-13	-10	-10	-8	-12
Interrup ted Dial	-15	-15	---	---	-10	-13	-10	-10	-8	-12
Mess age Notifica tion	-15	-15	---	---	-10	-13	-10	-10	-8	-12
Modem Answer	-24	-24	---	---	-19	-22	-19	-19	-17	-21
Over ride	-27	-27	---	---	-22	-25	-22	-22	-20	-24
Paging	-21	-21	---	---	-16	-19	-16	-16	-14	-18
Reor der	-15	-15	---	---	-10	-13	-10	-10	-8	-12
Ring back	-15	-15	---	---	-10	-13	-10	-10	-8	-12
Special Busy	-15	-15	---	---	-10	-13	-10	-10	-8	-12
Spec ial Ring back	-15	-15	---	---	-10	-13	-10	-10	-8	-12
Tran sfer Dial	-15	-15	---	---	-10	-13	-10	-10	-8	-12

Tone	Output Level (in dBm)									
	iONS abO NS	ONS	iOPS	OPS	iACO abA CO a bACO hl	iACO s ab ACOs	ACO	ACOs	DCO	ATT
Voice Mail	-21	-21	---	---	-16	-19	-12	-12	-14	-18

5.4.2 Brazil

Tone Plan

Tone	Frequency (Hz)	Cadence (s)
ARS 2nd Dial	425	Continuous
Busy	425	0.25 on, 0.25 off, repeat
Camp-on	425	0.06 on, 0.025 off, repeat x 2
Conference	440	1 on, off
Confirmation	425	Continuous
Dial Tone	425	0.975 on, 0.06 off, then repeat
Feature Active Dial	425	(0.125 on, 0.125 off) x 8, then continuous
Interrupted Dial	425	(0.1 on, 0.1 off) x 8, then continuous
Message Notification	425/440	425 (0.2 on, 0.2 off) x 4, then 440 (0.2 on, 0.2 off) x 2, then 425 (0.1 on, 0.1 off) x 4, then continuous
Modem Answer	2025	0.95 on, 0.05 off, repeat
Override	440	0.8 on, off
Paging	440	0.2 on, off
Reorder	425	0.25 on, 0.25 off, 0.75 on, 0.25 off, repeat
Ringback	424	1 on, 4 off, repeat
Special Busy	425	0.5 on, 0.5 off, repeat
Special Ringback	425	0.5 on, 0.5 off, 0.5 on, 2.5 off, repeat
Transfer Dial	425	(0.1 on, 0.1 off) x 3, then continuous
Voice Mail	440	0.6 on, off

Tone	Output Level (in dBm)									
	iONS abO NS	ONS	iOPS	OPS	iACO abA CO a bACO hl	iACO s ab ACOs	ACO	ACOs	DCO	ATT
ARS 2nd Dial	-23	-23	---	-20	-20	-20	-20	-20	-20	-20
Busy	-23	-23	---	-20	-20	-20	-20	-20	-20	-20
Dial	-23	-23	---	-20	-20	-20	-20	-20	-20	-20
Camp- on	-17	-17	---	-14	-14	-14	-14	-14	-14	-14
Confere nce	-19	-19	---	-16	-16	-16	-16	-16	-16	-16
Confirm ation	-23	-23	---	-20	-20	-20	-20	-20	-20	-20
Feature Active Dial	-23	-23	---	-20	-20	-20	-20	-20	-20	-20
Interrup ted Dial	-23	-23	---	-20	-20	-20	-20	-20	-20	-20
Mess age Notifica tion	-17	-17	---	-14	-14	-14	-14	-14	-14	-14
Modem Answer	-20	-20	---	-17	-17	-17	-17	-17	-17	-17
Over ride	-17	-17	---	-14	-14	-14	-14	-14	-14	-14
Paging	-17	-17	---	-14	-14	-14	-14	-14	-14	-14
Reor der	-23	-23	---	-20	-20	-20	-20	-20	-20	-20
Ring back	-23	-23	---	-20	-20	-20	-20	-20	-20	-20
Special Busy	-23	-23	---	-20	-20	-20	-20	-20	-20	-20
Spec ial Ring back	-23	-23	---	-20	-20	-20	-20	-20	-20	-20
Tran sfer Dial	-23	-23	---	-20	-20	-20	-20	-20	-20	-20
Voice Mail	-17	-17	---	-14	-14	-14	-14	-14	-14	-14

5.4.3 China

Tone Plan

Tone	Frequency (Hz)	Cadence (s)
ARS 2nd Dial	450	Continuous
Busy	450	0.35 on, 0.35 off, repeat
Camp-on	450	0.4 on, off
Conference	450	1.0 on, off
Confirmation	350/440	Continuous
Dial Tone	450	Continuous
Feature Active Dial	450	0.4 on, 0.4 off, then continuous
Interrupted Dial	450	0.4 on, 0.4 off, then continuous
Message Notification	350/440 400 350/440	350/440 (0.75 on, 0.75 off) x 2, then 400 0.1 on, 0.75 off, then 350/440 0.75 on, 0.75 off, then 350/440 continuous
Modem Answer	2025	0.95 on, 0.05 off, repeat
Override	440	0.8 on, off
Paging	440	0.2 on, off
Reorder	450	(0.1 on, 0.1 off) x 3, then 0.4 on, 0.4 off, repeat
Ringback	450	1 on, 4 off, repeat
Special Busy	350/440	0.35 on, 0.35 off, repeat
Special Ringback	400/450	0.4 on, 0.2 off, 0.4 on, 4 off, repeat
Transfer Dial	450	0.4 on, 0.04 off, then continuous

Tone	Output Level (in dBm)								
	ONS	abONS	OPS	ACO	abACO	ACOs	abACOs	DCO	ATT
ARS 2nd Dial	-3	-12	-4	-4	-7	-4	-7	-5	-10
Busy	-3	-12	-4	-4	-7	-4	-7	-5	-10
Camp-on	-13	-22	-14	-14	-17	-14	-17	-15	-20
Conference	-14	-23	-15	-15	-18	-15	-18	-16	-21
Confirmation	-3	-12	-4	-4	-7	-4	-7	-5	-10
Dial	-3	-12	-4	-4	-7	-4	-7	-5	-10

Tone	Output Level (in dBm)								
	ONS	abONS	OPS	ACO	abACO	ACOs	abACOs	DCO	ATT
Feature Active Dial	-3	-12	-4	-4	-7	-4	-7	-5	-10
Interrupted Dial	-3	-12	-4	-4	-7	-4	-7	-5	-10
Message Notification	-3,-4,-3	-12,-13,-12	-4,-5,-4	-4,-5,-4	-7,-8,-7	-4,-5,-4	-7,-8,-7	-5,-6,-5	-10,-11,-10
Modem Answer	-15	-24	-16	-16	-19	-16	-19	-17	-22
Override	-12	-23	-13	-13	-16	-13	-16	-14	-19
Paging	-12	-21	-13	-13	-16	-13	-16	-14	-19
Reorder	-3	-12	-4	-4	-7	-4	-7	-5	-10
Ring back	-3	-12	-4	-4	-7	-4	-7	-5	-10
Special Busy	-3	-12	-4	-4	-7	-4	-7	-5	-10
Special Ring back	-7	-16	-8	-8	-11	-8	-11	-9	-14
Transfer Dial	-3	-12	-4	-4	-7	-4	-7	-5	-10

5.4.4 France

Tone Plan

Tone	Frequency (Hz)	Cadence (s)
ARS 2nd Dial	440	Continuous
Busy	440	0.5 on, 0.5 off, repeat
Camp-on	520	0.2 on, off
Conference	400	0.6 on, off
Confirmation	440	Continuous
Dial Tone	440	Continuous
Feature Active Dial	440	0.75 on, 0.75 off, then continuous
Interrupted Dial	440	0.75 on, 0.75 off, then continuous
Message Notification	440/520/440	440 (0.75 on, 0.75 off) x 2, then 520 (0.2 on, 0.75 off) x 1, then 440 (0.75 on, 0.75 off, repeat forever)
Modem Answer	2025	0.95 on, 0.05 off, repeat
Override	1400	0.3 on, off

Tone	Frequency (Hz)	Cadence (s)
Paging	440	0.2 on, off
Reorder	440	0.5 on, 0.5 off, repeat
Ringback	440	1.5 on, 3.5 off, repeat
Special Busy	440	0.35 on, 0.35 off, repeat
Special Ringback	440	1.5 on, 3.5 off, repeat
Transfer Dial	440	(0.1 on, 0.1 off) x 3, then continuous
Voice Mail	440	0.6 on, off

Tone	Output Level (in dBm)									
	iONS abO NS	ONS	iOPS	OPS	iACO abA CO a bACO hl	iACOs	ACO	ACOs	DCO	ATT
ARS 2nd Dial	-20	-20	---	---	-15	-18	-15	-15	-13	-17
Busy	-20	-20	---	---	-15	-18	-15	-15	-13	-17
Dial	-20	-20	---	---	-15	-18	-15	-15	-13	-17
Camp- on	-20	-20	---	---	-15	-18	-15	-15	-13	-17
Confere nce	-20	-20	---	---	-15	-18	-15	-15	-13	-17
Confirm ation	-20	-20	---	---	-15	-18	-15	-15	-13	-17
Feature Active Dial	-20	-20	---	---	-15	-18	-15	-15	-13	-17
Interrup ted Dial	-20	-20	---	---	-15	-18	-15	-15	-13	-17
Mess age Notifica tion	-20 -23 -20	-20 -23 -20	---	---	-15 -18 -15	-18 -21 -18	-15 -18 -15	-15 -18 -15	-13 -16 -13	-17 -20 -17
Modem Answer	-24	-24	---	---	-19	-22	-19	-19	-17	-21
Over ride	-23	-23	---	---	-18	-21	-18	-18	-16	-20
Paging	-20	-20	---	---	-15	-18	-15	-15	-13	-17
Reor der	-20	-20	---	---	-15	-18	-15	-15	-13	-17
Ring back	-20	-20	---	---	-15	-18	-15	-15	-13	-17

Tone	Output Level (in dBm)									
	iONS abO NS	ONS	iOPS	OPS	iACO abA CO a bACO hl	iACOs	ACO	ACOs	DCO	ATT
Special Busy	-20	-20	---	---	-15	-18	-15	-15	-13	-17
Special Ringback	-20	-20	---	---	-15	-18	-15	-15	-13	-17
Transfer Dial	-20	-20	---	---	-15	-18	-15	-15	-13	-17
Voice Mail	-23	-23	---	---	-18	-21	-18	-18	-16	-20

5.4.5 Germany

Tone Plan

Tone	Frequency (Hz)	Cadence (s)
ARS 2nd Dial	425	Continuous
Busy	425	0.48 on, 0.48 off, repeat
Camp-on	425	0.25 on, off
Conference	425	0.25 on, off
Confirmation	425	0.1 on, 0.1 off, 0.1 on, 0.7 off, repeat
Dial	425	0.1 on, 0.1 off, 0.1 on, 0.7 off, repeat
External Camp-on	425	0.1 on, 0.05 off, 0.1 on, 0.05 off
Feature Active Dial	425	(0.95 on, 0.05 off) x 2, then (0.1 on, 0.1 off, 0.1 on, 0.7 off, repeat forever)
Interrupted Dial	425	(0.95 on, 0.05 off) x 2, then (0.1 on, 0.1 off, 0.1 on, 0.7 off, repeat forever)
Message Notification	425	(0.95 on, 0.05 off) x 2, then (0.1 on, 0.1 off, 0.1 on, 0.7 off, repeat forever)
Modem Answer	2025	0.95 on, 0.5 off, repeat
Override	1400	0.2 on, off
Paging	425	0.25 on, off
Reorder	425	0.24 on, 0.24 off, repeat
Ringback	425	1 on, 4 off, repeat
Special Busy	425	0.35 on, 0.35 off, repeat
Special Ringback	425	1 on, 4 off, repeat

Tone	Frequency (Hz)	Cadence (s)
Transfer Dial	425	0.1 on, 0.01 off, 0.1 on, 0.7 off, repeat
Voice Mail	440	0.6 on, off

Tone	Output Level (in dBm)									
	iONS abO NS	ONS	iOPS	OPS	iACO abA CO a bACO hl	iACOs	ACO	ACOs	DCO	ATT
ARS 2nd Dial	-15	-15	---	---	-10	-13	-10	-10	-8	-12
Busy	-15	-15	---	---	-10	-13	-10	-10	-8	-12
Dial	-15	-15	---	---	-10	-13	-10	-10	-8	-12
Camp- on	-15	-15	---	---	-10	-13	-10	-10	-8	-12
Confere nce	-15	-15	---	---	-10	-13	-10	-10	-8	-12
Confirm ation	-15	-15	---	---	-10	-13	-10	-10	-8	-12
Externa l Camp- on	-15	-15	---	---	-10	-13	-10	-10	-8	-12
Feat ure Acti ve Dial	-15	-15	---	---	-10	-13	-10	-10	-8	-12
Interrup ted Dial	-15	-15	---	---	-10	-13	-10	-10	-8	-12
Mess age Notifica tion	-15	-15	---	---	-10	-13	-10	-10	-8	-12
Modem Answer	-24	-24	---	---	-19	-22	-19	-19	-17	-21
Over ride	-27	-27	---	---	-22	-25	-22	-22	-20	-24
Paging	-21	-21	---	---	-16	-19	-16	-16	-14	-18
Reor der	-15	-15	---	---	-10	-13	-10	-10	-8	-12
Ring back	-15	-15	---	---	-10	-13	-10	-10	-8	-12
Special Busy	-15	-15	---	---	-10	-13	-10	-10	-8	-12

Tone	Output Level (in dBm)									
	iONS abO NS	ONS	iOPS	OPS	iACO abA CO a bACO hl	iACOs	ACO	ACOs	DCO	ATT
Spec ial Ring back	-15	-15	---	---	-10	-13	-10	-10	-8	-12
Tran sfer Dial	-15	-15	---	---	-10	-13	-10	-10	-8	-12
Voice Mail	-21	-21	---	---	-16	-19	-16	-16	-14	-18

5.4.6 Italy

Tone Plan

Tone	Frequency (hz)	Cadences(s)
ARS 2nd Dial	425	0.2 on, 0.2 off, 0.6 on, 1 off, repeat forever
Busy	425	0.2 on, 0.2 off, repeat forever
Camp-on	425	0.2 on, 0.1 off, 0.2 on, 0.1 off
Conference	425	0.2 on, off
Confirmation	425	0.1 on, 0.1 off, 0.1 on, 0.07 off, repeat
Dial	350/425	Continuous
Feature Active Dial	350/425	0.7 on, 0.7 off, repeat forever
Interrupted Dial	425	0.9 on, 0.1 off, then (0.1 on, 0.1 off, 0.1 on, 0.7 off, repeat forever)
Message Notification	425	0.7 on, 0.7 off
Modem Answer	2025	0.95 on, 0.05 off, repeat
Override	425	0.2 on, off
Paging	425	0.2 on, off
Reorder	425	0.2 on, 0.2 off, repeat forever
Ringback	425	1 on, 4 off, repeat
Special Busy	425	0.2 on, 0.2 off, repeat forever
Special Ringback	425	1 on, 4 off, repeat
Transfer Dial	350/425	0.75 on, 0.75 off, repeat
Voice Mail	440	0.6 on, off

Tone	Output Level (in dBm)									
	iONS abO NS	ONS	iOPS	OPS	iACO abA CO a bACO hl	iACOs	ACO	ACOs	DCO	ATT
ARS 2nd Dial	-17 -20	-13 -16	---	---	-12 -15	-16 -19	-16 -19	-15 -18	-10 -13	-16 -19
Busy	-17 -20	-13 -16	---	---	-12 -15	-15 -18	-16 -19	-15 -18	-10 -13	-16 -19
Dial	-17 -20	-13 -16	---	---	-12 -15	-15 -18	-16 -19	-15 -18	-10 -13	-16 -19
Camp- on	-17 -20	-13 -16	---	---	-12 -15	-15 -18	-16 -19	-15 -18	-10 -13	C
Confere nce	-17	-13	---	---	-12	-15	-16	-15	-10	-16
Confirm ation	-17 -20	-13 -16	---	---	-12 -15	-16 -19	-16 -19	-15 -18	-10 -13	-16 -19
Feat ure Acti ve Dial	-17 -20	-13 -16	---	---	-12 -15	-16 -19	-16 -19	-15 -18	-10 -13	-16 -19
Interrup ted Dial	-17 -20	-13 -16	---	---	-12 -15	-15 -18	-16 -19	-15 -18	-10 -13	-16 -19
Mess age Notifica tion	-17 -20	-13 -16	---	---	-12 -15	-16 -19	-16 -19	-15 -18	-10 -13	-16 -19
Modem Answer	-24	-20	---	---	-19	-22	-23	-22	-17	-23
Over ride	-27	-23	---	---	-22	-25	-26	-25	-20	-26
Paging	-20	-16	---	---	-15	-18	-19	-18	-13	-19
Reor der	-17 -20	-13 -16	---	---	-12 -15	-15 -18	-16 -19	-15 -18	-10 -13	-16 -19
Ring back	-17 -20	-13 -16	---	---	-12 -15	-15 -18	-16 -19	-15 -18	-10 -13	-16 -19
Special Busy	-17 -20	-13 -16	---	---	-12 -15	-15 -18	-16 -19	-15 -18	-10 -13	-16 -19
Spec ial Ring back	-17 -20	-13 -16	---	---	-12 -15	-16 -19	-16 -19	-15 -18	-10 -13	-16 -19
Tran sfer Dial	-17 -20	-13 -16	---	---	-12 -15	-15 -18	-16 -19	-15 -18	-10 -13	-16 -19
Voice Mail	-21	-17	---	---	-16	-19	-20	-19	-14	-20

5.4.7 Latin America

Tone Plan

Tone	Frequency (Hz)	Cadence (s)
ARS 2nd Dial	425	Continuous
Busy	480/620	0.5 on, 0.5 off, repeat
Camp-on	440	0.1 on, 0.05 off, repeat x 2
Conference	440	1 on, off
Confirmation	350/440	Continuous
Dial	350/440	Continuous
Feature Active Dial	350/440	(0.1 on, 0.1 off) x 8, then continuous
Interrupted Dial	350/440	(0.1 on, 0.1 off) x 8, then continuous
Message Notification	350/440	(0.1 on, 0.01 off) x 4, (0.2 on, 0.2 off) x 2, (0.1 on, 0.1 off) x 4, then continuous
Modem Answer	2025	0.95 on, 0.05 off, repeat
Override	440	0.8 on, off
Paging	440	0.2 on, off
Reorder	480/620	0.25 on, 0.25 off, repeat
Ringback	440/480	1 on, 3 off, repeat
Special Busy	480/620	0.5 on, 0.5 off, repeat
Special Ringback	440/480	0.5 on, 0.5 off, 0.5 on, 2.5 off, repeat
Transfer Dial	350/440	(0.1 on, 0.1 off) x 3, then continuous
Voice Mail	440	0.6 on, off

Tone	Output Level (in dBm)									
	iONS abO NS	ONS	iOPS	OPS	iACO abA CO a bACO hl	iACOs	ACO	ACOs	DCO	ATT
ARS 2nd Dial	-23	-23	---	-20	-20	-20	-20	-20	-20	-20
Busy	-27	-27	---	-24	-24	-24	-24	-24	-24	-24
Dial	-23	-23	---	-20	-20	-20	-20	-20	-20	-20
Camp-on	-17	-17	---	-14	-14	-14	-14	-14	-14	-14
Conference	-19	-19	---	-16	-16	-16	-16	-16	-16	-16

Tone	Output Level (in dBm)									
	iONS abO NS	ONS	iOPS	OPS	iACO abA CO a bACO hl	iACOs	ACO	ACOs	DCO	ATT
Confirmation	-23	-23	---	-20	-20	-20	-20	-20	-20	-20
Feature Active Dial	-22	-22	---	-19	-19	-19	-19	-19	-19	-19
Interrupted Dial	-23	-23	---	-20	-20	-20	-20	-20	-20	-20
Message Notification	-17	-17	---	-14	-14	-14	-14	-14	-14	-14
Modem Answer	-20	-20	---	-17	-17	-17	-17	-17	-17	-17
Override	-17	-17	---	-14	-14	-14	-14	-14	-14	-14
Paging	-17	-17	---	-14	-14	-14	-14	-14	-14	-14
Reorder	-27	-27	---	-24	-24	-24	-24	-24	-24	-24
Ring back	-22	-22	---	-19	-19	-19	-19	-19	-19	-19
Special Busy	-27	-27	---	-24	-24	-24	-24	-24	-24	-24
Special Ring back	-22	-22	---	-19	-19	-19	-19	-19	-19	-19
Transfer Dial	-23	-23	---	-20	-20	-20	-20	-20	-20	-20
Voice Mail	-17	-17	---	-14	-14	-14	-14	-14	-14	-14

5.4.8 The Netherlands

Tone Plan

Tone	Frequency (Hz)	Cadence (s)
ARS 2nd Dial	350/440	Continuous
Busy	425	0.5 on, 0.5 off, repeat
Camp-on	425	0.5 on, off
Conference	425	0.1 on, off

Tone	Frequency (Hz)	Cadence (s)
Confirmation	425	Continuous
Dial	425	Continuous
Feature Active Dial	425	0.75 on, 0.75 off, repeat
Interrupted Dial	425	0.4 on, 0.04 off, repeat forever
Message Notification	425/400/425	(0.75 on, 0.075 off) x 2, (0.1 on, 0.75 off), (0.75 on, 0.75 off, repeat)
Modem Answer	2025	0.95 on, 0.05 off, repeat
Override	425	0.2 on, off
Paging	425	0.2 on, off
Reorder	425	0.07 on, 0.07 off, repeat
Ringback	425	1 on, 4 off, repeat
Special Busy	425	0.5 on, 0.5 off, repeat
Special Ringback	425	1 on, 4 off, repeat
Transfer Dial	425	0.75 on, 0.75 off, repeat
Voice Mail	440	0.6 on, off

Tone	Output Level (in dBm)									
	iONS abONS	ONS	iOPS	OPS	iACO abACO ahl	iACO s ab ACOs	ACO	ACOs	DCO	ATT
ARS 2nd Dial	-16	-16	---	---	-11	-14	-11	-11	-9	-13
Busy	-16	-16	---	---	-11	-14	-11	-11	-9	-13
Dial	-16	-16	---	---	-11	-14	-11	-11	-9	-13
Camp- on	-16	-16	---	---	-11	-14	-11	-11	-9	-13
Confere nce	-18	-18	---	---	-13	-16	-13	-13	-11	-15
Confirm ation	-16	-16	---	---	-11	-14	-11	-11	-9	-13
Feature Active Dial	-16	-16	---	---	-11	-14	-11	-11	-9	-13
Interrup ted Dial	-16	-16	---	---	-11	-14	-11	-11	-9	-13
Mess age Notifica tion	-16	-16	---	---	-11	-14	-11	-11	-9	-13

Tone	Output Level (in dBm)									
	iONS abO NS	ONS	iOPS	OPS	iACO abA CO a bACO hl	iACO s ab ACOs	ACO	ACOs	DCO	ATT
Modem Answer	-24	-24	---	---	-19	-22	-19	-19	-17	-21
Override	-22	-22	---	---	-17	-20	-17	-17	-15	-19
Paging	-23	-23	---	---	-18	-21	-18	-18	-16	-20
Reorder	-16	-16	---	---	-11	-14	-11	-11	-9	-13
Ring back	-16	-16	---	---	-11	-14	-11	-11	-9	-13
Special Busy	-16	-16	---	---	-11	-14	-11	-11	-9	-13
Special Ring back	-16	-16	---	---	-11	-14	-11	-11	-9	-13
Transfer Dial	-16	-16	---	---	-11	-14	-11	-11	-9	-13
Voice Mail	-23	-23	---	---	-18	-21	-18	-18	-16	-20

5.4.9 New Zealand

Tone Plan

Tone	Frequency (Hz)	Cadence (s)
ARS 2nd Dial	400	Continuous
Busy	400	0.5 on, 0.5 off, repeat
Camp-on	520	0.2 on, off
Conference	400	0.6 on, off
Confirmation	1400	Continuous
Dial Tone	400	Continuous
Feature Active Dial	400	0.75 on, 0.75 off, then continuous
Interrupted Dial	400	0.75 on, 0.75 off, then continuous
Message Notification	400/520/400	400 (0.75 on, 0.75 off) x 2, then 520 (0.2 on, 0.75 off) x 1, then 400 (0.75 on, 0.75 off, repeat forever)
Modem Answer	2025	0.95 on, 0.05 off, repeat
Override	1400	0.3 on, off

Tone	Frequency (Hz)	Cadence (s)
Paging	440	0.2 on, off
Reorder	400	0.075 on, 0.1 off, 0.075 on, 0.75 off, repeat
Ringback	400/450	1 on, 2 off, repeat
Special Busy	400	0.35 on, 0.35 off, repeat
Special Ringback	400/450	0.4 on, 0.2 off, 0.4 on, 2.0 off, repeat forever
Transfer Dial	400	(0.1 on, 0.1 off) x 3, then continuous
Voice Mail	440	0.6 on, off

Tone	Output Level (in dBm)									
	iONS abONS	ONS	iOPS	OPS	iACO abACO aACO hl	iACOs	ACO	ACOs	DCO	ATT
ARS 2nd Dial	-11	-9	---	-10	-9	-8	-10	-10	-10	-10
Busy	-11	-9	---	-10	-9	-8	-10	-10	-10	-10
Dial	-11	-9	---	-10	-9	-8	-10	-10	-10	-10
Camp- on	-11	-9	---	-10	-7	-6	-8	-8	-8	-8
Confere nce	-14	-12	---	-13	-10	-8	-11	-11	-11	-11
Confirm ation	-11	-9	---	-10	-9	-8	-10	-10	-10	-10
Feature Active Dial	-11	-9	---	-10	-9	-8	-10	-10	-10	-10
Interrup ted Dial	-11	-9	---	-10	-9	-8	-10	-10	-10	-10
Mess age Notifica tion	-11 -13 -11	-9 -11 -9	---	-10 -12 -10	-9 -11 -9	-8 -10 -8	-10 -12 -10	-10 -12 -10	-10 -12 -10	-10 -12 -10
Modem Answer	-20	-18	---	-19	-16	-15	-17	-17	-17	-17
Over ride	-13	-11	---	-12	-9	-8	-10	-10	-10	-10
Paging	-17	-15	---	-16	-13	-12	-14	-14	-14	-14
Reor der	-11	-9	---	-10	-9	-8	-10	-10	-10	-10
Ring back	-11	-9	---	-10	-9	-8	-10	-10	-10	-10

Tone	Output Level (in dBm)									
	iONS abO NS	ONS	iOPS	OPS	iACO abA CO a bACO hl	iACOs	ACO	ACOs	DCO	ATT
Special Busy	-11	-9	---	-10	-9	-8	-10	-10	-10	-10
Special Ringback	-11	-9	---	-10	-9	-8	-10	-10	-10	-10
Transfer Dial	-11	-9	---	-10	-9	-8	-10	-10	-10	-10
Voice Mail	-17	-15	---	-16	-13	-12	-14	-14	-14	-14

5.4.10 North America

Tone Plan

Tone	Frequency (Hz)	Cadence (s)
ARS 2nd Dial	350/440	Continuous
Busy	480/620	0.5 on, 0.5 off, repeat
Camp-on	440	0.1 on, 0.05 off, repeat x 2
Conference	440	1 on, off
Confirmation	350/440	Continuous
Dial Tone	350/440	Continuous
Feature Active Dial	350/440	(0.1 on, 0.1 off) x 8, then continuous
Interrupted Dial	350/440	(0.1 on, 0.1 off) x 8, then continuous
Message Notification	350/440	350/440 (0.1 on, 0.1 off) x 4, then 440 (0.2 on, 0.2 off) x 2, then 350/440 (0.1 on, 0.1 off) x 4, then 350/440 continuous
Modem Answer	2025	0.95 on, 0.005 off, repeat
Override	440	0.8 on, off
Paging	440	0.2 on, off
Reorder	480/620	0.25 on, 0.25 off, repeat
Ringback	440/480	1 on, 3 off, repeat
Special Busy	480/620	0.5 on, 0.5 off, repeat
Special Ringback	440/480	0.5 on, 0.5 off, 0.5 on, 2.5 off, repeat
Transfer Dial	350/440	(0.1 on, 0.1 off) x 3, then continuous
Voice Mail	440	0.6 on, off

Note: This plan also provides support for United States MultiLevel Precedence and Preemption (MLPP) priority.

Tone	Output Level (in dBm)									
	iONS abO NS	ONS	iOPS	OPS	iACO abA CO a bACO hl	iACOs	ACO	ACOs	DCO	ATT
ARS 2nd Dial	-23	-23	---	-20	-20	-20	-20	-20	-20	-20
Busy	-27	-27	---	-24	-24	-24	-24	-24	-24	-24
Dial	-23	-23	---	-20	-20	-20	-20	-20	-20	-20
Camp- on	-17	-17	---	-14	-14	-14	-14	-14	-14	-14
Confere nce	-19	-19	---	-16	-16	-16	-16	-16	-16	-16
Confirm ation	-23	-23	---	-20	-20	-20	-20	-20	-20	-20
Feature Active Dial	-22	-22	---	-19	-19	-19	-19	-19	-19	-19
Interrup ted Dial	-23	-23	---	-20	-20	-20	-20	-20	-20	-20
Mess age Notifica tion	-17	-17	---	-14	-14	-14	-14	-14	-14	-14
Modem Answer	-20	-20	---	-17	-17	-17	-17	-17	-17	-17
Over ride	-17	-17	---	-14	-14	-14	-14	-14	-14	-14
Paging	-17	-17	---	-14	-14	-14	-14	-14	-14	-14
Reor der	-27	-27	---	-24	-24	-24	-24	-24	-24	-24
Ring back	-22	-22	---	-19	-19	-19	-19	-19	-19	-19
Special Busy	-23	-23	---	-20	-20	-20	-20	-20	-20	-20
Spec ial Ring back	-22	-22	---	-19	-19	-19	-19	-19	-19	-19
Tran sfer Dial	-23	-23	---	-20	-20	-20	-20	-20	-20	-20

Tone	Output Level (in dBm)									
	iONS abO NS	ONS	iOPS	OPS	iACO abA CO a bACO hl	iACOs	ACO	ACOs	DCO	ATT
Voice Mail	-17	-17	---	-14	-14	-14	-14	-14	-14	-14

5.4.11 Portugal

Tone Plan

Tone	Frequency (Hz)	Cadence (s)
ARS 2nd Dial	400	Continuous
Busy	425	0.2 on, 0.2 off, repeat
Camp-on	425	0.2 on, 0.01 off, 0.2 on, 0.1 off
Conference	425	0.2 on, off
Confirmation	425	0.1 on, 0.1 off, 0.1 on, 0.7 off, repeat
Dial	350/425	Continuous
Feature Active Dial	350/425	0.7 on, 0.7 off, repeat
Interrupted Dial	425	0.9 on, 0.1 off, then (0.1 on, 0.1 off, 0.1 on, 0.7 off, repeat forever)
Message Notification	425	0.7 on, 0.07 off
Modem Answer	2025	0.95 on, 0.05 off, repeat
Override	425	0.2 on, off
Paging	425	0.2 on, off
Reorder	425	0.2 on, 0.2 off, repeat
Ringback	425	1 on, 4 off, repeat
Special Busy	425	0.2 on, 0.2 off, repeat
Special Ringback	425	1 on, 4 off, repeat
Transfer Dial	350/425	Continuous
Voice Mail	440	0.6 on, off

Tone	Output Level (in dBm)									
	iONS abO NS	ONS	iOPS	OPS	iAC O ab ACO abAC Ohl	iACOs	ACO	ACOs	DCO	ATT
ARS 2nd Dial	-17	-17	---	---	-12	-15	-12	-12	-10	-14

Tone	Output Level (in dBm)									
	iONS abO NS	ONS	iOPS	OPS	iAC O ab ACO abAC Ohl	iACOs	ACO	ACOs	DCO	ATT
Busy	-17	-17	---	---	-12	-15	-12	-12	-10	-14
Dial	-17	-17	---	---	-12	-15	-12	-12	-10	-14
Camp- on	-17	-17	---	---	-12	-15	-12	-12	-10	-14
Confere nce	-17	-17	---	---	-12	-15	-12	-12	-10	-14
Confirm ation	-17	-17	---	---	-12	-15	-12	-12	-10	-14
Feature Active Dial	-17	-17	---	---	-12	-15	-12	-12	-10	-14
Interrup ted Dial	-17	-17	---	---	-12	-15	-12	-12	-10	-14
Mess age Notifica tion	-17	-17	---	---	-12	-15	-12	-12	-10	-14
Modem Answer	-24	-24	---	---	-19	-22	-19	-19	-17	-21
Over ride	-27	-27	---	---	-22	-25	-22	-22	-20	-24
Paging	-20	-20	---	---	-15	-18	-15	-15	-13	-17
Reor der	-17	-17	---	---	-12	-15	-12	-12	-10	-14
Ring back	-17	-17	---	---	-12	-15	-12	-12	-10	-14
Special Busy	-17	-17	---	---	-12	-15	-12	-12	-10	-14
Spec ial Ring back	-17	-17	---	---	-12	-15	-12	-12	-10	-14
Tran sfer Dial	-17	-17	---	---	-12	-15	-12	-12	-10	-14
Voice Mail	-21	-21	---	---	-16	-19	-16	-16	-14	-18

5.4.12 Spain

Tone Plan

Tone	Frequency (Hz)	Cadence (s)
ARS 2nd Dial	425	Continuous
Busy	425	0.2 on, 0.2 off, repeat
Camp-on	425	0.6 on, 0.2 off, 0.6 on, off
Conference	1400	0.4 on, off
Confirmation	425	Continuous
Dial	425	Continuous
Feature Active Dial	425	(0.1 on, 0.1 off) x 8, then continuous
Interrupted Dial	425	(0.1 on, 0.1 off), repeat x 8, then continuous
Message Notification	425, 440, 425	425 (0.1 on, 0.01 off) x 4, then 440 (0.2 on, 0.2 off) x 2, then 425 (0.1 on, 0.1 off) x 4, then 425 continuous
Modem Answer	2025	0.95 on, 0.05 off, repeat
Override	1400	0.2 on, off
Paging	440	0.2 on, off
Reorder	425	0.2 on, 0.2 off, 0.2 on, 0.6 off, repeat
Ringback	425	1.5 on, 3 off, repeat
Special Busy	425	0.2 on, 0.2 off, repeat
Special Ringback	425	0.5 on, 0.5 off, 0.5 on, 2.5 off, repeat
Transfer Dial	425	0.1 on, 0.s off, 0.1 on, 0.1 off, 0.1 on, 0.1 off, then continuous
Voice Mail	440	0.6 on, off

Tone	Output Level (in dBm)									
	iONS abONS	ONS	iOPS	OPS	iACO abACO ahl	iACOs	ACO	ACOs	DCO	ATT
ARS 2nd Dial	-17	-17	---	---	-12	-15	-12	-12	-10	-14
Busy	-17	-17	---	---	-12	-15	-12	-12	-10	-14
Dial	-17	-17	---	---	-12	-15	-12	-12	-10	-14
Camp-on	-17	-17	---	---	-12	-15	-12	-12	-10	-14
Conference	-17	-17	---	---	-12	-15	-12	-12	-10	-14
Confirmation	-17	-17	---	---	-12	-15	-12	-12	-10	-14

Tone	Output Level (in dBm)									
	iONS abO NS	ONS	iOPS	OPS	iACO abA CO a bACO hl	iACOs	ACO	ACOs	DCO	ATT
Feature Active Dial	-17	-17	---	---	-12	-15	-12	-12	-10	-14
Interrupted Dial	-17	-17	---	---	-12	-15	-12	-12	-10	-14
Message Notification	-17	-17	---	---	-12	-15	-12	-12	-10	-14
Modem Answer	-24	-24	---	---	-19	-22	-19	-19	-17	-21
Override	-27	-27	---	---	-22	-25	-22	-22	-20	-24
Paging	-21	-21	---	---	-16	-19	-16	-16	-14	-18
Reorder	-17	-17	---	---	-12	-15	-12	-12	-10	-14
Ring back	-17	-17	---	---	-12	-15	-12	-12	-10	-14
Special Busy	-17	-17	---	---	-12	-15	-12	-12	-10	-14
Special Ring back	-17	-17	---	---	-12	-15	-12	-12	-10	-14
Transfer Dial	-17	-17	---	---	-12	-15	-12	-12	-10	-14
Voice Mail	-21	-21	---	---	-16	-19	-16	-16	-14	-18

5.4.13 United Kingdom

Tone Plan

Tone	Frequency (Hz)	Cadence (s)
ARS 2nd Dial	350/440	Continuous
Busy	400	0.35 on, 0.35 off, repeat
Camp-on	400	0.1 on, off
Conference	400	0.1 on, off
Confirmation	350/440	Continuous
Dial	350/440	Continuous

Tone	Frequency (Hz)	Cadence (s)
Feature Active Dial	350/440	0.75 on, 0.75 off, repeat
Interrupted	1400	0.1 on, off
Message Notification	350/440	350/440 (0.75 on, 0.75 off) x 2, then 440 (0.1 on, 0.75 off), then 350/440 (0.75 on, 0.75 off, repeat)
Modem Answer	2025	0.95 on, 0.05 off, repeat
Number Unobtainable	400	Continuous
Paging	440	0.2 on, off
Ringing (Internal)	400/450	1 on, 2 off, repeat
Special Busy	400	0.35 on, 0.35 off, repeat
Special Ringing (External)	400/450	0.4 on, 0.2 of, 0.4 on, 2 off, repeat
Transfer Dial	350/440	0.75 on, 0.75 off, repeat
Interrupted Dial	350/440	0.75 on, 0.75 off, repeat
Voice Mail	440	0.6 on, off

Tone	Output Level (in dBm)									
	iONS abO NS	ONS	iOPS	OPS	iACO abA CO a bACO hl	iACOs	ACO	ACOs	DCO	ATT
ARS 2nd Dial	-8, -12, -17, -22	-7, -11, -16, -21	---	-10, -14 , -19, - 24	-4, -8, -13, -18	-3, -7, -12, -17	-4, -8, -13, -18	-4, -8, -13, -18	-5, -9, -14, -19	-4, -8, -13, -18
Busy	-9, -14, -19	-8, -13, -18	---	-11, -16 , -21	-5, -10, -15	-4, -9, - 14	-5, -10, -15	-5, -10, -15	-6, -11, -16	-5, -10, -15
Dial	-8, -12, -17, -22	-7, -11, -16, -21	---	-10, -14 , -19, - 24	-4, -8, -13, -18	-3, -7, -12, -17	-4, -8, -13, -18	-4, -8, -13, -18	-5, -9, -14, -19	-4, -8, -13, -18
Camp- on	-9, -14, -19	-8, -13, -18	---	-11, -16 , -21	-5, -10, -15	-4, -9, - 14	-5, -10, -15	-5, -10, -15	-6, -11, -16	-5, -10, -15
Conf erence	-14	-13	---	-16	-10	-9	-10	-10	-11	-10
Conf irmation	-8, -12, -17, -22	-7, -11, -16, -21	---	-10, -14 , -19, - 24	-4, -8, -13, -18	-3, -7, -12, -17	-4, -8, -13, -18	-4, -8, -13, -18	-5, -9, -14, -19	-4, -8, -13, -18
Feat ure Acti ve Dial	-8, -12, -17, -22	-7, -11, -16, -21	---	-10, -14 , -19, - 24	-4, -8, -13, -18	-3, -7, -12, -17	-4, -8, -13, -18	-4, -8, -13, -18	-5, -9, -14, -19	-4, -8, -13, -18
Interrup ted Dial	-8, -12, -17, -22	-7, -11, -16, -21	---	-10, -14 , -19, - 24	-4, -8, -13, -18	-3, -7, -12, -17	-4, -8, -13, -18	-4, -8, -13, -18	-5, -9, -14, -19	-4, -8, -13, -18

Tone	Output Level (in dBm)									
	iONS abO NS	ONS	iOPS	OPS	iACO abA CO a bACO hl	iACOs	ACO	ACOs	DCO	ATT
Message Notification	-9 -14	-8 -13	---	-11 -16	-5 -10	-4 -9	-5 -10	-5 -10	-6 -11	-5 -10
Modem Answer	-20	-19	---	-22	-16	-15	-16	-16	-17	-16
Override	-18	-17	---	-20	-14	-13	-14	-14	-15	-14
Paging	-19	-18	---	-21	-15	-14	-15	-15	-16	-15
Reorder	-9, -14, -19	-8, -13, -18	---	-11, -16, -21	-5, -10, -15	-4, -9, -14	-5, -10, -15	-5, -10, -15	-6, -11, -16	-5, -10, -15
Ring back	-12, -17, -22	-11, -16, -21	---	-14, -19, -21	-8, -13, -18	-7, -12, -17	-8, -13, -18	-8, -13, -18	-9, -14, -19	-8, -13, -18
Special Busy	-8, -12, -17, -22	-7, -11, -16, -21	---	-10, -14, -19, -24	-10, -14, -19, -24	-3, -7, -12, -17	-4, -8, -13, -18	-4, -8, -13, -18	-5, -9, -14, -19	-4, -8, -13, -18
Special Ring back	-4, -8, -13, -18	-4, -8, -13, -18	---	-14, -19, -24	-14, -19, -21	-14, -19, -21	-8, -13, -18	-8, -13, -18	-9, -14, -19	-9, -14, -19
Transfer Dial	-8 -12	-7 -11	---	-10 -14	-4 -8	-3 -7	-4 -8	-4 -8	-5 -9	-4 -8
Voice Mail	-19	-18	---	-21	-15	-14	-15	-15	-16	-15

Appendix B : Ethernet Cabling Guidelines

This chapter contains the following sections:

- [Maximum Cable Lengths](#)
- [Cabling Guidelines for the Desktop](#)
- [Cabling Guidelines in the Equipment Room](#)
- [Category 3 Cabling Guidelines \(CXi II\)](#)

Introduction

The 3300 ICP system transmits voice communications over a data network using Voice over Internet Protocol (VoIP). Electrical interference in the environment can reduce the quality of the voice and data signals that are transmitted over Ethernet cable. Desktop computers, printers, servers, lighting, and other office devices place a high demand on the electrical infrastructure and increase the risk of electrical interference. You can minimize electrical interference and improve network efficiency by following the cabling guidelines detailed in this appendix.

Note:

Special testing equipment is available from Mitel Product Support. This equipment can verify Ethernet cable performance and detect cable faults.

6.1 Maximum Cable Lengths

Table 70: Maximum CAT 5 or CAT 5e Ethernet Cable Lengths

Cabling	Maximum Length
Under Desk	10 ft. (3 m)
Floor to ceiling	11.5 ft. (3.5 m)
Horizontal span in ceiling	300 ft. (90 m)
Equipment closet	11.5 ft. (3.5 m)
Total maximum length	333 ft. (100 m)

6.2 Cabling Guidelines for the Desktop

Refer to [Figure 21: Desktop Cabling](#) and the corresponding cabling guidelines to minimize electrical interference at the desktop.

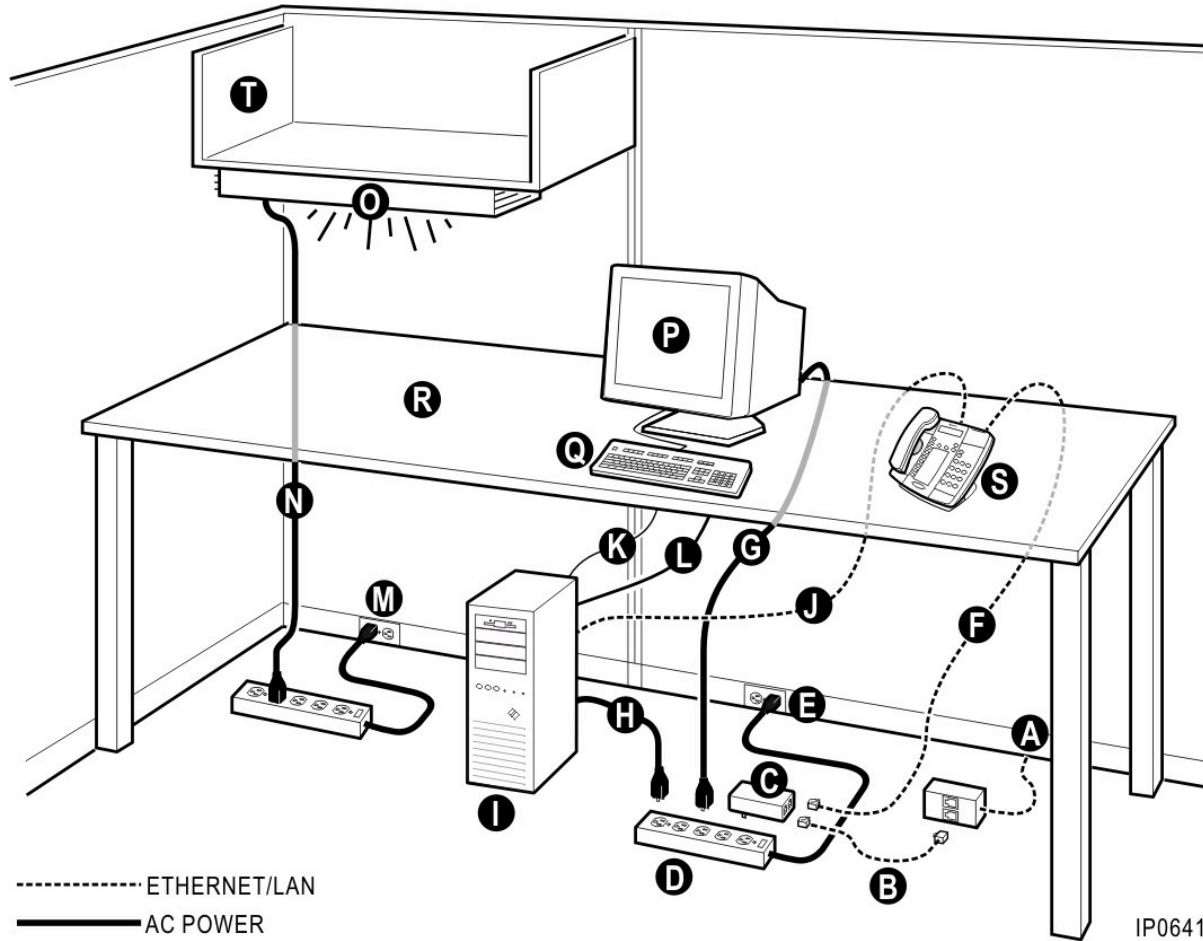

Figure 21: Desktop Cabling

Table 71: Desktop Environment Cabling Guidelines

Connection		Guidelines
A	Ethernet connection to network	<ul style="list-style-type: none"> • Use CAT 5 or CAT 5e Ethernet cables and certified network connection blocks (TIA/EIA 568A). Adhere to the cable lengths listed on Maximum Cable Lengths.

Connection		Guidelines
B	Network to power adapter Ethernet patch cable (for local power configuration only)	<ul style="list-style-type: none"> • Use CAT 5 or CAT 5e cables (certified to TIA/EIA 568A) • Maximum length 5 ft. (1.5 m) • Route cable away from sources of interference, such as power cables
C	IP Phone power adapter (for local power configuration only)	<ul style="list-style-type: none"> • Plug IP Phone power adapter and the computer into the same surge-suppressing power bar
D	Surge suppressing power bar	<ul style="list-style-type: none"> • Recommended model is American Power Conversion “SurgeArrest” • Route power cables away from Ethernet cables
E	Power outlet for desktop equipment	<ul style="list-style-type: none"> • Use outlet to supply power to computer and IP Phone power adapter only • Do not plug other devices such as florescent lights, coffee makers, kettles into this outlet
F	Phone to power brick Ethernet connection	<ul style="list-style-type: none"> • Use CAT 5 or CAT 5e cables (certified to TIA/EIA 568A) • Maximum length 5 ft. (1.5 m) • Route cable away from sources of interference, such as power cables

Connection		Guidelines
G	Monitor power cord	<ul style="list-style-type: none"> • Plug into computer power bar • Route cable away from Ethernet cables
H	Computer power cord	
I	Computer	
J	Phone to computer Ethernet connection	<ul style="list-style-type: none"> • Use CAT 5 or CAT 5e cables (certified to TIA/EIA 568A) • Maximum length 5 ft. (1.5 m) • Route cable away from sources of interference, such as power cables
K	Keyboard to computer connection	<ul style="list-style-type: none"> • Route cable as required for convenience
L	Monitor to computer connection	<ul style="list-style-type: none"> • Route cable away from Ethernet cables
M	Power connection to auxiliary equipment	<ul style="list-style-type: none"> • Use a separate power outlet for potential noise generating devices such as a lamp, coffee maker, or radio
N	Florescent light power cord	<ul style="list-style-type: none"> • Route cable away from Ethernet cables

Connection		Guidelines
O	Florescent desk light	<ul style="list-style-type: none"> Ballast circuitry inside florescent lamps will create noise spikes on power cables when the lamps are turned off. Ensure that florescent lamps are plugged into dedicated surge suppressing power bars. Voltage limiting devices inside the power bars reduce noise spikes and reduce the risk of data errors. Some desks have power outlets that are designated for the computer and utility devices. These outlets have built-in surge protection. In this case, a power bar is not required.

6.3 Cabling Guidelines in the Equipment Room

Refer to [Figure 22: Equipment Room Cabling](#) and the corresponding cabling guidelines to minimize electrical interference in the equipment room.

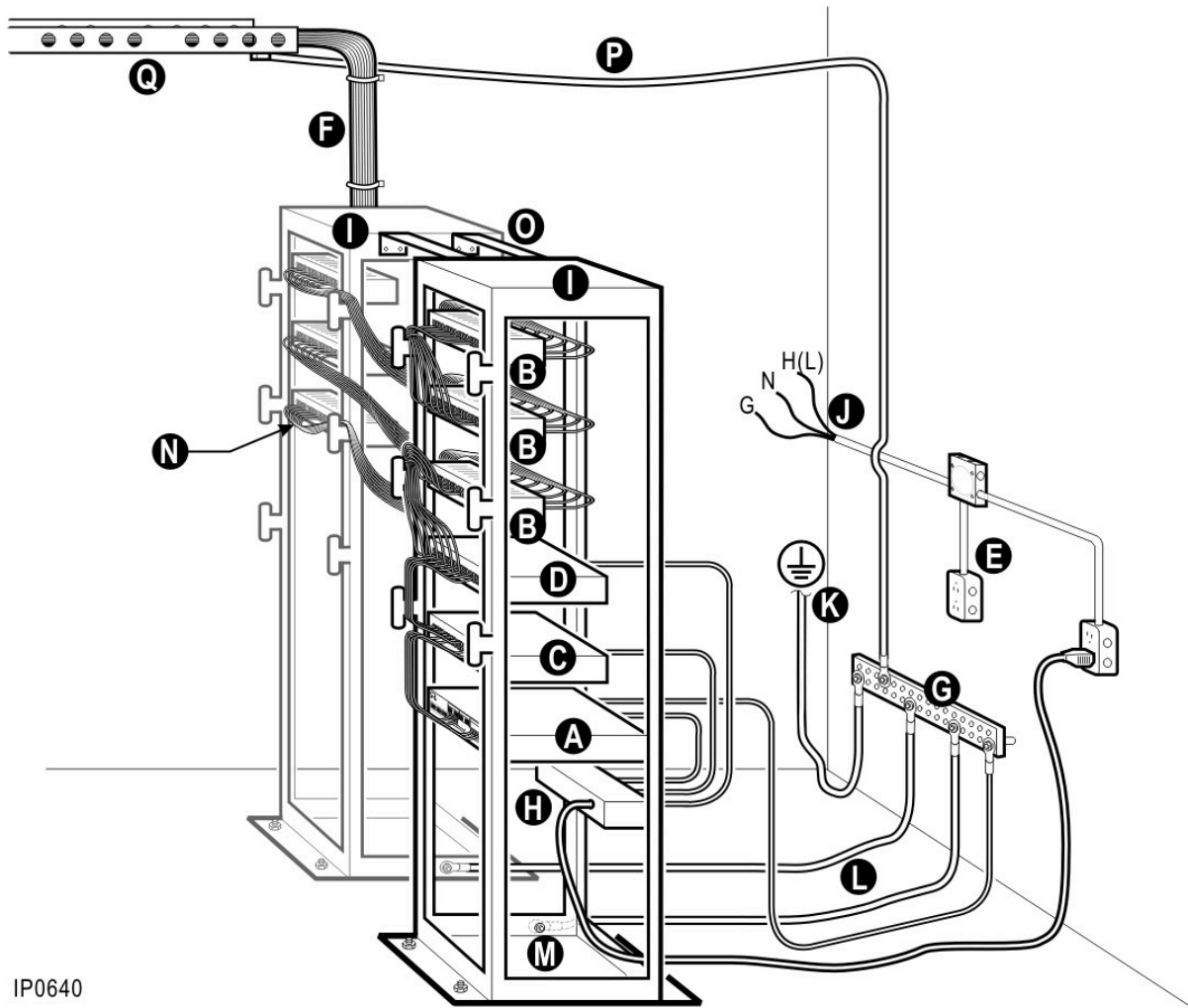

IP0640

Figure 22: Equipment Room Cabling

Table 72: Equipment Room Cabling Guidelines

Connection		Guidelines
A	3300 ICP controller	<ul style="list-style-type: none"> • Use CAT 5, CAT 5e, or CAT 6 Ethernet connector blocks and cables • CAT 5e or CAT 6 certified cable provides better immunity to crosstalk • Connect ground stud on back of controller to ground bar bus (G) with a dedicated ground wire

Connection		Guidelines
B	Patch panel	<ul style="list-style-type: none"> • Patch panels must be certified for CAT 5 cable • Do not use punch-down blocks that are designed for voice-grade telephony signals to interconnect 100 Mbps Ethernet signals. • Recommended connector blocks can be obtained from www.anixter.com (part number 201011)
C	Layer 2 switch	<ul style="list-style-type: none"> • If a ground stud is provided, connect it to the ground bar bus (G) with a dedicated ground wire. Use the wire gauge specified by the manufacturer • Powered hubs supply IP Phones with power through the Ethernet cable either through the spare wires or the signal pairs. IP Phones that have power adapters do not use powered hubs. • If a ground stud is provided, connect it to the ground bar bus (G) with a dedicated ground wire. Use the wire gauge specified by the manufacturer
D	Powered hub	<ul style="list-style-type: none"> • Powered hubs supply IP Phones with power through the Ethernet cable either through the spare wires or the signal pairs. IP Phones that have power adapters do not use powered hubs. • If a ground stud is provided, connect it to the ground bar bus (G) with a dedicated ground wire. Use the wire gauge specified by the manufacturer

Connection		Guidelines
E	Protected power system	<ul style="list-style-type: none"> • Dedicate the use of the power outlets to the equipment in the equipment room only. • Ensure that the power outlets in the equipment room are wired for 15 Amp service directly to the electrical service panel with ideally one circuit breaker per outlet. • If the site is configured with resilient IP phones, ensure that the 3300 controllers are powered by dedicated power bars. • Switching power supplies common in computers and telecommunications equipment generate noise voltages, known as harmonics. Use oversize neutral conductors to minimize harmonics. • Ensure that conduits include a dedicated copper ground
F	Cable	<ul style="list-style-type: none"> • Ensure that the maximum cable runs do not exceed 333 ft. (100 m).

Connection		Guidelines
G	Ground bar bus	<ul style="list-style-type: none"> • Use a ground bus bar that is $\frac{1}{4}$ inch thick and 2 inches wide and long enough to accommodate the grounding for all the rack-mounted equipment • Recommended bus bar is ANIXTER part number 179639 • Mount the bus bar on the wall with insulated standoffs • Use compression style fittings to fasten the ground wire lugs to the bar • Connect the bus bar to the main building ground with a 6 AWG copper, stranded, green-colored cable. • For grounding specifications see ITU-T K.27 "Building configurations and earthings inside a telecommunications building" and ANSI/TIA/EIA-607

Connection		Guidelines
H	Protected rack-mount power strip	<ul style="list-style-type: none"> • If you cannot provide dedicated 15 Amp power outlets for each unit in the rack, mount a surge-arresting power strip on the front or rear of the rack. • Recommended model is the Surge Arrest - Rack Mount model from American Power Conversion. The ground from the rack forms part of the shield for the power strip. • Plastic floor type models are not recommended because they are more likely to be turned off by accident. <p>CAUTION: Power bars have a circuit breaker. If the circuit breaker is tripped due to a power surge, the power to all the outlets on the power bar is shut off. If the site supports resilient IP Phones, ensure that the controllers are plugged into different power bars.</p>

Connection		Guidelines
I	Standard metal rack	<ul style="list-style-type: none"> • Bolt each rack securely to the floor and connect a dedicated ground wire between the frame and the ground bus bar. • If rack-mounted equipment obtains safety ground from the metal rack, ensure that a good electrical connection is made between the rack and the cabinet metalwork. Use “star” washers to obtain a solid electrical connection to painted cabinets • Route any power cables contained within the rack away from any UTP patch cabling <p>Note:Fiber optic cabling can be routed anywhere within the rack because it is not susceptible to electrical emissions.</p>
J	AC Mains metal conduit	<ul style="list-style-type: none"> • Metal conduit that contains power wiring must have three wires for each dedicated circuit: Ground (bare), Neutral (White), Hot or Line (Black). Do not use the conduit as the ground.
K	Telecoms main ground	<ul style="list-style-type: none"> • Main ground connector must be 6 AWG stranded, copper, green-colored cable connected to the main building ground. <p>CAUTION:A proper ground is required for proper equipment operation and safety. A power quality engineer can provide advice on new and existing installations. Refer to row G in this table for additional information.</p>
L	Rack grounds	<ul style="list-style-type: none"> • Use separate wires to ground each rack to the ground bus bar

Connection		Guidelines
M	Equipment grounds	<ul style="list-style-type: none"> Use separate wires to ground each piece of equipment to the ground bus bar. If a ground stud is provided on the back of the unit, connect it to the ground bus bar with a dedicated ground wire (use the gauge specified by the manufacturer).
N	Patch cable	<ul style="list-style-type: none"> Interconnect Ethernet equipment supporting 100 Mbps transmission with CAT 5 UTP patch cable. Label the cables and route them neatly through the channels provided in the metal rack. <p>CAUTION: Do not use voice grade twisted pair interconnect patch cable wired to standard voice grade punch-down blocks on an IDE</p>
O	Metal rack interconnect	<ul style="list-style-type: none"> The metal brackets used to connect the racks provide mechanical connection only. Use a dedicated ground wire to ground each rack separately to the ground bus bar.
P	Cable tray ground	<ul style="list-style-type: none"> Connect the metal racks that house the Ethernet cable to the ground bus bar to provide an effective shield against potential noise sources such as power lines and florescent lights.
Q	Cable tray	<ul style="list-style-type: none"> The tray should contain Ethernet cables only. Do not mix power cables with Ethernet cables

6.4 Category 3 Cabling Guidelines (CXi II)

Category 5 cable is recommended for all network connections, but the CXi II controller can support Category 3 cable subject to the following general guidelines:

- Category 3 cable can be used for one purpose only: to connect single Ethernet devices (IP phones or PCs) directly to the controller or a Layer 2 expansion switch; see [Figure 23: Recommended Ethernet Cabling for CXi II](#).
- Category 5 (or better) cable is required for all other Ethernet connections, including:
 - connections from "dual devices" (IP phone and PC) to the controller or an expansion switch
 - uplink connections between switches
 - connections from the Internet to the 10/100 WAN port
 - connections to the T1/E1 Combo module
 - connections to the Quad Copper Interface module from ASUs, or Peripheral Cabinets
- If a connection uses Category 3 cable, restrict its port speed to 10 Mbps and half duplex. It is preferable to program the settings on the switch (onboard or expansion) rather than the connected device.
- Category 3 cable can supply Power over Ethernet (PoE) via the controller's phantom power feed.
- The cable installation must meet Category 3 standards (TIA/EIA-568).

Note:

1. Not all telecom cable is Category 3-compliant.
2. Detailed guidelines concerning the use of Category 3 cable can be found in the the Engineering Guidelines document on the Mitel Edocs web site. (<http://edocs.mitel.com>). Refer to this document before starting the installation.
3. Some expansion switches may not support PoE with Category 3 cable.

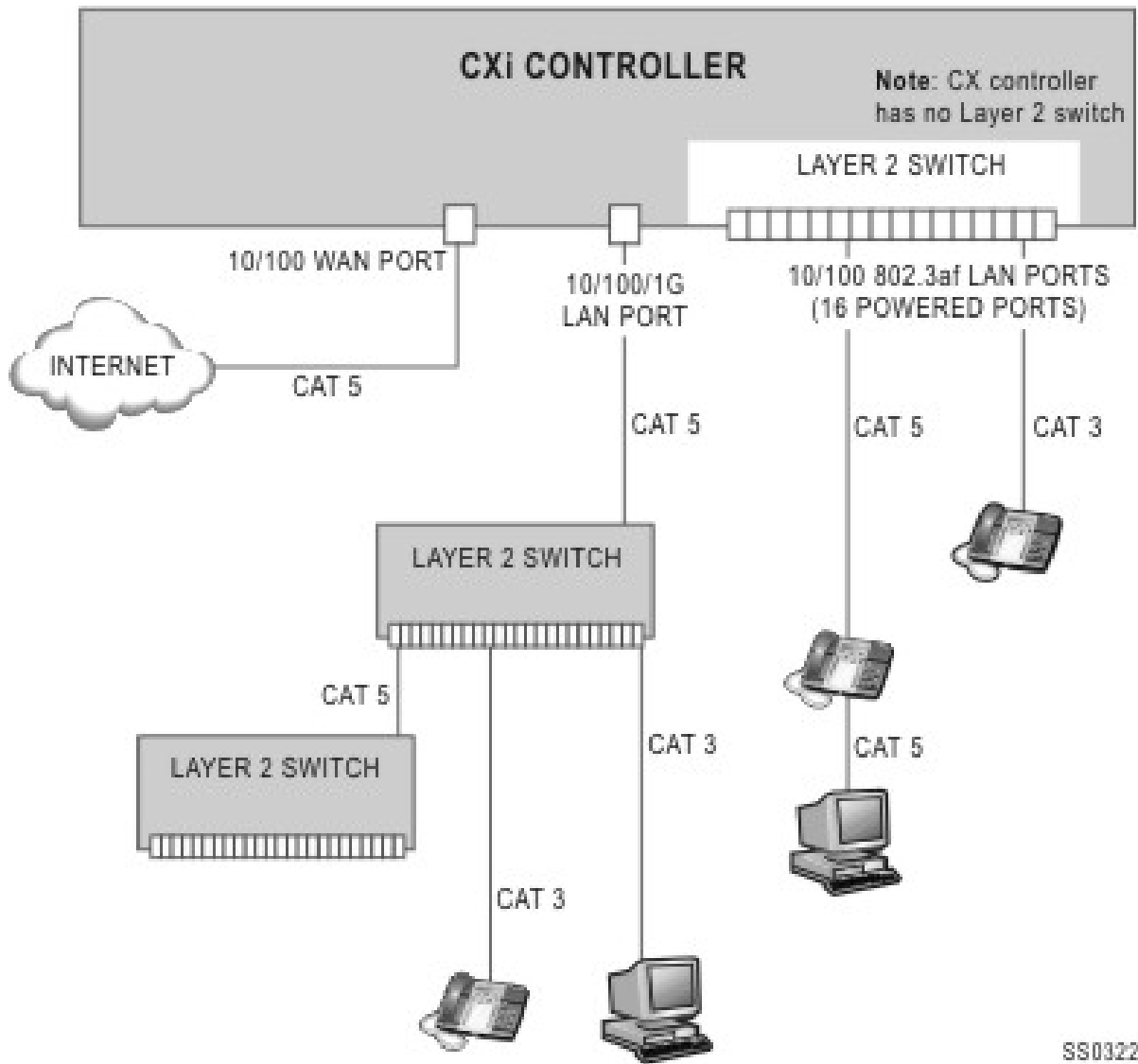

Figure 23: Recommended Ethernet Cabling for CXi II

