



A MITEL
PRODUCT
GUIDE

Mitel OpenScape Business

OpenScape Business X1R

Installation and Service Guide

06/2026

Notices

The information contained in this document is believed to be accurate in all respects but is not warranted by Mitel Europe Limited. The information is subject to change without notice and should not be construed in any way as a commitment by Mitel or any of its affiliates or subsidiaries. Mitel and its affiliates and subsidiaries assume no responsibility for any errors or omissions in this document. Revisions of this document or new editions of it may be issued to incorporate such changes. No part of this document can be reproduced or transmitted in any form or by any means - electronic or mechanical - for any purpose without written permission from Mitel Networks Corporation.

Trademarks

The trademarks, service marks, logos, and graphics (collectively “Trademarks”) appearing on Mitel’s Internet sites or in its publications are registered and unregistered trademarks of Mitel Networks Corporation (MNC) or its subsidiaries (collectively “Mitel), Unify Software and Solutions GmbH & Co. KG or its affiliates (collectively “Unify”) or others. Use of the Trademarks is prohibited without the express consent from Mitel and/or Unify. Please contact our legal department at iplegal@mitel.com for additional information. For a list of the worldwide Mitel and Unify registered trademarks, please refer to the website: <http://www.mitel.com/trademarks>.

© Copyright 2026, Mitel Networks Corporation

All rights reserved

Contents

1 History of changes.....	6
2 Introduction and Important Notes.....	7
2.1 About this Guide.....	7
2.2 Symbols.....	7
2.3 Scope of Delivery.....	9
2.3.1 Accessories and Spare Parts.....	9
2.3.2 Shipment, Packaging and Unpacking.....	10
2.4 Safety Information.....	10
2.4.1 General Safety Instructions and Important Notes.....	10
2.4.2 Safety with electricity.....	12
2.4.2.1 High Voltage Safety.....	12
2.4.3 Special Handling and Unpacking Instructions.....	13
2.4.4 Lithium Battery Precautions.....	13
2.4.5 Accessing Internal Components.....	14
2.4.6 Electrostatic Discharge (ESD).....	15
2.4.7 Protective Grounding (PE).....	15
2.4.8 Lightning Protection Requirements.....	17
2.4.9 Connecting to the Power Supply Circuit.....	17
2.5 Operating Considerations.....	18
2.5.1 Environmental Operating Conditions.....	18
2.5.2 Cooling.....	18
2.5.3 Mechanical Operating Conditions.....	19
2.6 Connecting of telecom lines and phones.....	19
2.7 Connecting of LAN and WAN lines.....	20
2.8 Checklist for finalizing assembly work.....	21
2.9 Care and Cleaning Instructions.....	21
2.10 Quality and Environmental Management.....	21
2.10.1 Disposal and Recycling.....	21
2.10.2 WEEE Compliance.....	22
2.11 Data Protection and Data Security.....	22
2.12 Markings.....	23
3 System description.....	25
3.1 OpenScape Business X1R.....	25
3.2 Boards.....	25
3.2.1 Overview of Modules.....	25
3.2.2 X1R Interfaces.....	27
3.2.3 CMAe.....	33
3.2.4 OCCBL and OCCBH.....	35
4 Preparing for the Installation of OpenScape Business X1R.....	37
4.1 Prerequisites for the Installation.....	37
4.2 Preparatory Steps.....	38
4.2.1 How to Unpack the Components.....	38
4.2.2 How to open the X1R.....	38
5 Installing the Hardware for OpenScape Business X1R.....	40
5.1 Type of Installation.....	40
5.1.1 How to Mount the Communication System to a Wall.....	40
5.1.2 How to Mount the Communication System to a Rack.....	42
5.1.3 How to Mount the Communication System as a Desk System.....	44

5.2 Protective Grounding.....	44
5.2.1 How to Check the Grounding.....	44
5.3 WAN, LAN and Admin Port.....	45
5.3.1 How to Set up a WAN, LAN or Admin Connection.....	45
5.4 Connecting Phones and Devices.....	46
5.4.1 How to Connect U _{P0/E} Phones.....	46
5.4.2 How to Connect Analog Devices.....	47
5.5 Closing Activities.....	48
5.5.1 How to Install a M.2 SATA / NVMe SSD on OCCSBR or OCCSAR.....	48
5.5.2 How to Install CMAe.....	49
5.5.3 How to Install OCCBL or OCCBH on OCCSBR or OCCSAR.....	51
5.5.4 How to Perform a Visual Inspection.....	53
5.5.5 How to Close the Communication System.....	54
5.5.6 How to Connect the System to the Mains.....	54
6 Initial Setup for OpenScape Business X1R.....	55
6.1 Prerequisites for the Initial Installation.....	55
6.2 Components.....	56
6.3 Dial Plan.....	57
6.4 IP Address Scheme.....	58
6.5 Initial Startup.....	59
6.5.1 How to Restart the Communication System.....	60
6.5.2 How to Connect the Admin PC to the Communication System.....	60
6.5.3 How to Start the WBM.....	61
6.6 Integration into the Customer LAN.....	63
6.6.1 How to Start the Initial Installation Wizard.....	63
6.6.2 System Settings.....	64
6.6.2.1 How to Set the Display Logo and the Product Name.....	64
6.6.2.2 How to Specify the IP Addresses (Optional).....	65
6.6.2.3 How to Specify the Device Name.....	66
6.6.3 DHCP Settings.....	66
6.6.3.1 How to Disable the Internal DHCP Server.....	67
6.6.3.2 How to Enable and Configure the Internal DHCP Server.....	67
6.6.4 Country and Time Settings.....	69
6.6.4.1 How to Select the Country Code and the Language for Event Logs.....	69
6.6.4.2 How to Enter the DECT System ID.....	70
6.6.4.3 How to Set the Date and Time Manually.....	70
6.6.4.4 How to Obtain the Date and Time from an SNTP Server.....	71
6.6.5 UC Solution.....	72
6.6.5.1 How to Define the UC Solution.....	72
6.6.6 Connecting the Communication System to the Customer LAN.....	73
6.6.6.1 How to Connect the Communication System to the Customer LAN.....	73
6.7 Basic Configuration.....	74
6.7.1 How to Start the Basic Installation Wizard.....	74
6.7.2 System Phone Numbers and Networking.....	74
6.7.2.1 How to Enter the System Phone Numbers for a Point-to-Point connection.....	75
6.7.2.2 How to Enter the System Phone Numbers for a Point-to-Multipoint Connection.....	76
6.7.2.3 How to Activate or Deactivate Networking.....	77
6.7.3 Station Data.....	78
6.7.3.1 How to Display the Station Data.....	79
6.7.3.2 How to Delete all Call Numbers.....	79
6.7.3.3 How to Adapt Preconfigured Station Numbers for the Individual Dial Plan.....	80
6.7.3.4 How to Import the Station Data from an XML File.....	81
6.7.3.5 How to display Mass data.....	81
6.7.4 Internet Access.....	82
6.7.4.1 How to Configure Internet Access via an External Internet Router over the LAN Port.....	84

6.7.4.2	How to Configure Internet Access via an External Internet Router over the WAN Port.....	84
6.7.4.3	How to Configure Internet Access via a Preconfigured ISP.....	85
6.7.4.4	How to Configure Internet Access via the Standard ISP PPPoE.....	87
6.7.4.5	How to Configure Internet Access via a Standard ISP PPTP.....	89
6.7.4.6	How to Disable Internet Access.....	91
6.7.5	Internet Telephony.....	92
6.7.5.1	How to Configure a Predefined ITSP.....	93
6.7.5.2	How to Deactivate Internet Telephony.....	97
6.7.6	Stations.....	97
6.7.6.1	How to Configure Analog Stations.....	98
6.7.6.2	How to Configure U _{P0/E} Stations.....	101
6.7.6.3	How to Configure DECT Stations.....	104
6.7.6.4	How to Configure IP and SIP Stations.....	107
6.7.7	Configuring UC Suite.....	110
6.7.7.1	How to Configure the UC Suite.....	110
6.7.8	Configuring UC Smart Mailboxes.....	111
6.7.8.1	How to Configure UC Smart Voicemail Boxes.....	111
6.7.9	Conference Server Settings.....	112
6.7.9.1	How to Edit the Conference Server Settings.....	112
6.7.10	E-mail Delivery (Optional).....	112
6.7.10.1	How to Configure the Sending of E-mails.....	113
6.8	Closing Activities.....	115
6.8.1	How to Activate and Assign the Licenses.....	116
6.8.2	How to Provision the UC Smart Client for Installation.....	119
6.8.3	How to Provision the UC Suite Clients for Installation.....	119
6.8.4	How to Perform a Data Backup.....	120
6.9	Commissioning of IP Phones.....	121
6.9.1	How to Configure an IP Phone.....	122
6.9.2	How to Configure a SIP Phone.....	123
6.10	Reasons for System Restart.....	125
6.10.1	System restart for OpenScape Business X1R.....	125
7	Integrated Cordless Solution.....	128
7.1	System Overview.....	128
7.1.1	System Configuration.....	129
7.1.2	Traffic capacity.....	129
7.1.3	Grade Of Service (GOS).....	130
7.1.4	Single-Cell Mode.....	131
7.2	Testing a Cordless Solution.....	131
7.2.1	Checking the Base Stations and the Radio Coverage.....	132
7.2.1.1	Testing Base Stations.....	133
7.2.1.2	Check the Radio Coverage.....	134
7.2.2	Documentation of the Test Results.....	135
7.3	Troubleshooting.....	136
8	Appendix.....	138
8.1	Interface Ranges for Subscriber Lines.....	138

1 History of changes

Changes mentioned in the following list are cumulative.

Changes in V4

Impacted chapters	Change description
-	Initial creation of the document

2 Introduction and Important Notes

2.1 About this Guide

This guide focuses on describing the special features of the OpenScape Business X1R (OSBiz X1R). Administrators and Service Technicians are recommended to study the instructions within this guide before switching on the power.

Intended Audience

The audience of this guide is Unify Professional Services and Back Level Support personnel. Note that this does not preclude other Unify personnel, customers, or third-party service providers who have the necessary prerequisite knowledge from using the guide.

Prerequisite Knowledge

This guide is written to the instructed or skilled personnel who has:

- Successfully completed the Unify OpenScape Business installation and technical training courses.
- Basic knowledge of the third-party platforms and equipment used for OpenScape Business including: their physical characteristics, their assembly, their documentation (installation, service, and troubleshooting), and the documentation web sites associated with the third-party platform and equipment manufacturers.
- Basic knowledge of the industry standards and specifications utilized by OpenScape Business and associated equipment.

2.2 Symbols

The following symbols may be used in this guide.

 **DANGER** **DANGER** indicates a hazardous situation which, if not avoided, will result in death or serious injury.

 **WARNING** **WARNING** indicates a hazardous situation which, if not avoided, could result in death or serious injury.

 **CAUTION** **CAUTION** indicates a hazardous situation which, if not avoided, may result in minor or moderate injury.

 **NOTICE** **NOTICE** indicates a property damage message.



Electric Shock!

This symbol and title warn of hazards due to electrical shocks when touching products or parts of products. Failure to observe the precautions indicated and/or prescribed by the law may endanger your life/health and/or result in damage to your material.



ESD Sensitive Device!

This symbol and title inform that the electronic products and their components are sensitive to static electricity. Care must therefore be taken during all handling operations and inspections of this product in order to always ensure product integrity.



Connection, protective conductor (PE)!

This symbol informs of HIGH TOUCH CURRENT - Before connecting to the telecommunication network, be sure to make the grounding connection.



Protective Earth (PE)!

This symbol marks the connection point for protective conductor (PE) on the device.



This symbol indicates general information about the product and the guide.

This symbol also indicates detail information about the specific product configuration.



WEEE

Products marked with the WEEE symbol must not be disposed of with household waste but must be taken to separate collection points for reuse and recycling.

2.3 Scope of Delivery

Check that your delivery is complete, and contains the items listed in Table.
If damaged or missing items are discovered, contact the dealer.

Part Number	Qty	Description
S30777-U782-X11 S30777-U782-X2 S30777-U782-X111 (second M.2 NVMe) S30777-U782-X201 (X1RA) S30777-U782-X101	1 pcs	OpenScape Business X1R with mainboard OCCSBR, and M2: SSD incl. SW and OpenScape Business X1R Advance (X1RA) with mainboard OCCSBR, and M2: SSD incl. SW
C39165-A7035-D4	1 pcs	Mounting kit for wall mounting or mounting in a 19" rack and self-adhesive rubber feet
F31505-G15-A7	1 pcs	Handling Hints
F31505-G15-A15	1 pcs	Safety Checklist



Power cords are not included in delivery. The appropriate country specific power cord must be ordered separately.



Additional installation materials are NOT included in the product delivery and can be ordered as a separate option.

2.3.1 Accessories and Spare Parts

Part Number	Description
F31505-E5-A31	M.2 Memory-Card with system software
S30807-Q6957-X	CMAE (CMI Module with ADPCM Enhanced)
S30807-Q6956-X1	OCCBL (DSP module - extension by 40 channels)
S30807-Q6956-X2	OCCBH (DSP module - extension by 120 channels)
C39195-Z7001-C11	AC Power Cable EU (Type E+F – C13 straight, 250 cm)
C39195-Z7001-C12	AC Power Cable US (Type B – C13 straight, 250 cm)
C39195-Z7001-C17	AC Power Cable EU (Type E+F – C13 angled, 250 cm)
C39195-Z7001-C20	AC Power Cable UK (Type G – C13 angled, 250 cm)

Introduction and Important Notes

Safety Information

C39195-Z7001-C32	AC Power Cable UK (Type G – C13 straight, 250 cm)
C39195-Z7001-C38	AC Power Cable CH (Type J – C13 straight, 250 cm)
C39195-Z7001-C57	AC Power Cable AUS (Type I – C13 straight, 250 cm)
C39195-Z7001-C97	AC Power Cable US (Type B – C13 angled, 250 cm)
C39195-Z7001-C191	AC Power Cable BRA (Type N – C13 angled, 250 cm)

⚠ WARNING

The OpenScope Business X1R may only be installed by instructed or skilled person, familiar with the associated dangers.

⚠ WARNING

During the mounting procedure into a 19" rack or on a wall the OpenScope Business X1R must be powered down and the power cord must be disconnected from the power source.



Only use original accessories and spare parts approved by Unify Software and Solutions GmbH & Co. KG.

2.3.2 Shipment, Packaging and Unpacking

The OpenScope Business X1R is packed together with all standard parts in a product specific cardboard packaging with suitable shock absorbers inside.

Each item is packaged separately.



Please refer to 1.5.3 Special Handling and Unpacking Instructions.

2.4 Safety Information

⚠ WARNING

Read and observe the instructions within this chapter that have been compiled for the operator's safety and to ensure accordance with regulations. If the following "General Safety Instructions" are not observed, it could lead to injuries to the operator and/or damage to the product. The manufacturer is exempt from accident liability, also during the warranty period if the instructions within this guide are not observed.

2.4.1 General Safety Instructions and Important Notes

The product has been built and tested according to the basic safety requirements for low voltage applications (IEC 62368-1) and has left the

manufacturer in a safety-related, flawless condition. To maintain this condition and to ensure safe operation, the operator must observe the correct operating conditions for the product and following general safety instructions:

- The product must be used as specified in the instructions for safety for the product and for the operator, as described within this guide. The guide contains guidelines for setting up, assembly, installation, maintenance, transport and storage.
- The on-site electrical installation must meet the requirements of the country's specific local regulations.
- The communication system should only be operated with outlets that have connected ground contacts.
- During a thunderstorm, do not connect or disconnect lines and do not install or remove boards.
- If supplied with a power cable, only use the supplied power cable.
- Replace the power cable immediately if it appears to be damaged.
- Do not use an extension cable to connect the product.
- Use separate ground wires to provide protective grounding for the communication system. Before you start up the system and connect the phones and phone lines, connect the communication system with a permanent earthing conductor (PE).
- Only use communication lines with a conductor diameter of 0.4 mm (AWG 26) or more.
- To guarantee that sufficient air flow is available to cool the product, ensure that ventilation openings are not covered or blocked.
- Do not place the product close to heat sources or damp places.
- Only connect devices or parts that fulfil the requirements of circuits as stipulated by IEC 62368-1 to the available interfaces.
- Before opening the product, make sure that the product is disconnected from the mains.
- Switching off the product by the power button does not disconnect the product from the mains. Complete disconnection is only possible if the power cable is removed from the wall plug or from the product.
- The AC power cord plug must be always easily accessible to enable quick disconnection from the mains.
- The product may only be opened for the insertion or removal of add-on cards (depending on the configuration of the system). This should only be carried out by sufficiently instructed or skilled personnel.
- If extensions are being carried out, the following must be observed:
 - All effective legal regulations and technical data are adhered to.
 - Power consumption of any add-on card does not exceed the specified limitations.
 - Current consumption of the product does not exceed the value stated on the type label.
- Only use original accessories and spare parts approved by Unify Software and Solutions GmbH & Co. KG.
- NOTE: safe operation is no longer possible when any of the following applies:
 - Product has visible damage.
 - Product is no longer functioning In these cases, the product must be switched off and disconnected from the mains. Additionally, ensured that the product can no longer be operated.

Introduction and Important Notes

- After completing test and maintenance work, make sure that all safety equipment is re-installed in the right place.
- Install cables in such a way that they do not pose a risk of an accident (tripping) and cannot be damaged.
- When working on an open communication system, make sure that it is never left unattended.
- When working on the systems, never wear loose clothing and always tie back long hair.
- Do not wear jewelry, metal watch bands or clothes with metal ornaments or rivets.
- Always wear the necessary eye protection whenever appropriate.
- Always wear a hard hat where there is a risk of injury from falling objects.
- Make sure that the work area is well lit and tidy.
- Sudden changes in temperature can result in condensing humidity. If a communication system or server is transported from a cold environment to warmer areas, for example, this could result in the condensation of humidity.
- Wait until the communication system or server has adjusted to the ambient temperature and is completely dry before starting it up.
- If backup power is unavailable or fails to switch to analogue emergency phones in the event of a power failure, emergency calls can no longer be made through the communications system in the event of a power failure.
- Before beginning wall mounting, check whether the wall has sufficient load-bearing capacity. Always use suitable installation and fastening materials to securely mount the communication system.
- Do not store flammable materials in the immediate vicinity of the communication system.

2.4.2 Safety with electricity

The OpenScape Business X1R product was developed and tested carefully to provide all features necessary to ensure its compliance with electrical safety requirements. It was also designed for a long fault-free life. However, the life expectancy of your product can be drastically reduced by improper treatment during unpacking and installation.

Therefore, in the interest of your own safety and of the correct operation of the OpenScape Business X1R, you are requested to conform with the following guidelines.

2.4.2.1 High Voltage Safety

As a precaution and in case of danger, the power connectors must be easily accessible. The power connectors are the product's main disconnect device.

CAUTION Warning

All operations on this product must be carried out by sufficiently instructed or skilled personnel only.



Electric Shock!

Before installing the OpenScape Business X1R into a communication system always ensure that your main power is switched off. This also applies to the installation of sub modules.

Serious electrical shock hazards can exist during all installation, repair, and maintenance operations on this product. Therefore, always unplug all power cables and any other cables which provide external voltages before performing any work on this product.

Protective conductor (PE) connection shall remain connected to a central grounding point.

The protective conductor (PE) cable shall be the last cable to be disconnected or the first cable to be connected when performing installation or removal procedures on this product.

2.4.3 Special Handling and Unpacking Instructions



ESD Sensitive Device!

Electronic products and their components are sensitive to static electricity. Therefore, care must be taken during all handling operations and inspections of this product, in order to always ensure product integrity.

CAUTION

Handling and operation of the product is permitted only for instructed or skilled personnel within a workplace that is access controlled. Follow the "General Safety Instructions" supplied with the product (see 1.5.1 General Safety Instructions).

Do not handle this product out of its protective enclosure while it is not used for operational purposes unless it is otherwise protected.

Whenever possible, unpack or pack this product only at ESD safe workstations. Where a safe workstation is not guaranteed, it is important for the operator to be electrically discharged before touching the product with his/her hands or tools. This is most easily done by touching a metal part of your system housing.

It is particularly important to observe standard anti-static precautions when changing piggybacks, ROM devices, jumper settings etc. If the product contains batteries for RTC or memory backup, ensure that the product is not placed on conductive surfaces, including anti-static plastics or sponges. They can cause short circuits and damage the batteries or conductive circuits on the product.

2.4.4 Lithium Battery Precautions

When replacing the mainboard's lithium battery observe the instructions described in 1.5.1 General Safety Instructions.

⚠ WARNING Danger of explosion when replaced with wrong type of battery or if the battery is replaced incorrectly!

Replace the lithium battery only with the same or equivalent type recommended by the manufacturer. The lithium battery type must be UL recognized.

Dispose of used lithium batteries according to the manufacturer's instructions.



⚠ Do not dispose of lithium batteries in general trash collection. Dispose of the battery according to the local regulations dealing with the disposal of these special materials, (e.g. to the collecting points for dispose of batteries).

2.4.5 Accessing Internal Components

This chapter contains important information on working safely with internal components. Follow these instructions when handling internal components and observe the corresponding safety instructions included in 1.5.1 General Safety Instructions.

⚠ WARNING Energy hazards - 100-240 VAC present inside the chassis!

Before removing the top cover, switch off the product properly disconnecting the power cable from the mains power supply.

⚠ WARNING Activities requiring internal access of the product must be performed by instructed or skilled personnel aware of the associated dangers!



ESD Sensitive Device!

Follow the safety instructions for components that are sensitive to electrostatic discharge (ESD). Failure to observe this warning notice can result in damage to the components.

2.4.6 Electrostatic Discharge (ESD)



A sudden discharge of electrostatic electricity can destroy static-sensitive devices.

Proper packaging and grounding techniques are necessary precautions to prevent damage. Always take the following precautions:

- Transport ESD-sensitive products in ESD-safe containers such as boxes or bags.
- Keep electrostatic sensitive parts in their containers until they arrive at the ESD-safe workplace.
- Always be properly grounded when touching sensitive products, components, or assembly.
- Store electrostatic-sensitive products in protective packaging or on antistatic mats.
- Avoid working on standard carpets as they tend to generate electrostatic charges.

ESD Grounding Methods

To avoid electrostatic damage, observe the following grounding guidelines:

- Cover workstations with approved antistatic material. Always wear a wrist strap connected to the workplace. Always use properly grounded tools and equipment.
- Use antistatic mats, antistatic wristband, heel straps, or air ionizers for more protection.
- Always handle electrostatically sensitive components by their edge or by their casing.
- Avoid contact with pins, leads, or circuitry.
- Switch off power and input signals before inserting and removing connectors or connecting test equipment.
- Keep work area free of non-conductive materials such as ordinary plastic assembly aids and Styrofoam.
- Use only field service tools that are conductive, such as cutters, screwdrivers, and vacuum cleaners.
- Always place any boards PCB-assembly-side down on a grounded conductive base

2.4.7 Protective Grounding (PE)

The protective grounding provides a secure connection to the ground potential to protect against dangerously high touch voltages in the event of a malfunction.

⚠ DANGER Risk of electric shock through contact with live wires!

Only instructed or skilled personnel with proper qualifications or qualified electricians should perform work on the low-voltage network (<1000 VAC) and all work must comply with the national/local requirements for electrical connections.

⚠ WARNING Risk of electric shock through contact with live wires!

Use separate ground wires to provide protective grounding (PE) for the OpenScape Business X1R communication system and possibly any main distribution frames being used. Connect your communication system and your main distribution frame to the ground wire before starting up the system and connecting telephones and lines.

Make sure that the ground wires laid are protected and strain relieved.



Figure 1: Protective grounding equipment



Figure 2: Assembly of the protection ground terminal

Put together the cable clamp, using the M4 screw and the toothed washer.

2.4.8 Lightning Protection Requirements

The protection of communication system against high-energy surges requires a low-impedance ground connection.



Once a communication system has been grounded, check the low-impedance ground connection of the system using the ground conductor of the mains power supply circuit and the low-impedance connection (of the additional permanently connected protective ground conductor) to the building's potential equalization bus.

NOTICE

Fire hazard due to surge voltage!

Telecom lines which exceeding a length of 500m or leave the building must be protected by an additional external lightning protection.

Lightning protection of this kind is known as additional primary protection. The additional primary protection is guaranteed by the professional installation of ÜSAGs (surge arresters, gas filled) in the main distribution frame, the patch panel or at the entry point of the pipe in the building. A gas-filled surge arrester with 230 V nominal voltage is switched to ground from each wire that is to be protected.

Without this additional primary protection, lightning could irreparably damage the communication system. This can cause the entire communication system to fail or result in components overheating (fire hazard).

2.4.9 Connecting to the Power Supply Circuit

The communication system has been approved for connection to TN-S power supply systems. They can also be connected to a TN-C-S power supply system in which the PEN conductor is divided into a ground wire and a neutral wire. TN-S and TN-C-S systems are defined in the IEC 60364-1 and IEC 60364-5-51 standard.

⚠ DANGER

Risk of electric shock through contact with live wires!

Only qualified electricians should perform any work that may be required on the low-voltage network. These installation activities to connect the communication system must be performed in compliance with IEC 60364-1 and IEC 60364-4-41 or any corresponding legal norms or national regulations.

⚠ DANGER Risk of electric shock!

The OpenScape Business X1R may only be switched on when the housing is closed.

2.5 Operating Considerations

Note the environmental and mechanical conditions for operating OpenScape Business X1R.

NOTICE Damage caused by exposed to excessive dust

The communication system must not be exposed to excessive dust.

NOTICE Damage caused by chemical influences

Avoid any chemical influences on the communication system must be avoided.

2.5.1 Environmental Operating Conditions

Operating limits:

- Room temperature: + 5 °C to + 40 °C (41 °F to 104 °F)
- Absolute humidity: 1 g H₂O/m³ to 25 g H₂O/m³
- Relative humidity: 5% to 80%

2.5.2 Cooling

NOTICE Damage caused by overheating due to insufficient clearance

The ventilation of the communication system is by convection only.

To ensure adequate ventilation of the communication system, a minimum distance of 10 cm must be maintained on the left and right of the housing.

Ensure that the ventilation openings on the side of the housing are not covered or blocked by surrounding parts.



There are no ventilation restrictions above or below the product, allowing installation directly above or below another system.

NOTICE

Damage caused by local temperature increases

Avoid exposing the communication systems to direct sunlight and other heat sources.

NOTICE

Damage caused by condensation due to humidity

Avoid any condensation of humidity on or in the communication systems before or during operation under all circumstances.

A communication system must be completely dry before you put it into service.

2.5.3 Mechanical Operating Conditions

The communication system is intended for stationary use and can be installed or mounted as follows:

- as a desktop device
- in a 19" rack
- on a wall



Make sure there is enough space and clearance for installation and maintenance work on the communication system.

⚠ WARNING

Maximum mounting height

The mounting of the OpenScape Business X1R is not allowed over 2m, for safety reasons.

NOTICE

Damage caused by incorrect wall mounting

Before beginning wall mounting, check whether the wall has sufficient load-bearing capacity. Always use suitable installation and fastening materials to securely mount the communication system.

Please provide the screws (diameter min. 4 mm) and dowels for fixing the OpenScape Business X1R to the wall, depending on the condition of the wall.

2.6 Connecting of telecom lines and phones

Different types of telecom lines and analog phones can be connected to the OpenScape Business X1R. The connection is made directly at the front of the mainboard.

Introduction and Important Notes

Connecting of LAN and WAN lines

⚠ WARNING

Risk of electric shock through contact with live wires!

Use separate ground wires to provide protective grounding (PE) for your communication system and any main distribution frames used before connecting telephones and lines.

⚠ CAUTION

Fire hazard!

To reduce the risk of fire, you may only use communication cables with a conductor diameter of at least 0.4mm (AWG 26) or larger.

NOTICE

Fire hazard due to surge voltage!

Telecom lines which exceeding a length of 500m or leave the building must be protected by an additional external lightning protection.

Lightning protection of this kind is known as additional primary protection. The additional primary protection is guaranteed by the professional installation of ÜSAGs (surge arresters, gas filled) in the main distribution frame, the patch panel or at the entry point of the pipe in the building. A gas-filled surge arrester with 230 V nominal voltage is switched to ground from each wire that is to be protected.

Without this additional primary protection, lightning could irreparably damage the communication system. This can cause the entire communication system to fail or result in components overheating (fire hazard).

2.7 Connecting of LAN and WAN lines



The operation of the communication system is only permitted on a building-internal LAN cabling. The communication system shall be connected to the IP infrastructure with a shielded LAN cable: Cat-5 for 100 Mb/s or Cat-6 for 1000 Mb/s.

In the electrical building installation, it must be ensured that the shield of the LAN cable is grounded.

2.8 Checklist for finalizing assembly work

⚠ WARNING Before concluding assembly work, please verify the “Safety Checklists – OpenScape Business X1R“.

The questions relate to conformity of the product to legal requirements and in particular to product safety and electromagnetic compatibility. Since these are legal requirements, extreme care is needed when performing the relevant assembly and installation activities.

If you cannot unequivocally answer the questions with "yes" or "not relevant", please check carefully whether the requirements in the installation instructions are complied with fully.

2.9 Care and Cleaning Instructions

⚠ DANGER Risk of fire and electric shock!

Never spray liquids onto the communication system, as liquids that penetrate can lead to risk of fire, electric shock, malfunctions, or destruction of the device.



Only clean the outside of the communication system housing with a soft cloth moistened with water.

NOTICE Also, do not use any substances for cleaning such as alcohol, chemicals, solvents or abrasives, as these may damage the surface of the case.

2.10 Quality and Environmental Management

Unify Software and Solutions GmbH & Co. KG aims to deliver reliable high-end products designed and built for quality, and aims to complying with environmental laws, regulations, and other environmentally oriented requirements.

Unify Software and Solutions GmbH & Co. KG is certified for its Quality Management System according to ISO 9001:2015 and for its Environmental Management System according to ISO 14001:2015.

2.10.1 Disposal and Recycling

Products by Unify Software and Solutions GmbH & Co. KG are manufactured to satisfy environmental protection requirements where possible. Many of the components used are capable of being recycled. Final disposal of this product

Introduction and Important Notes

Data Protection and Data Security

after its service life must be accomplished in accordance with applicable country, state, or local laws or regulations.

2.10.2 WEEE Compliance

The Waste Electrical and Electronic Equipment (WEEE) Directive aims to:

- Reduce waste arising from electrical and electronic equipment (EEE)
- Make producers of EEE responsible for the environmental impact of their products, especially when the product become waste.
- Encourage separate collection and subsequent treatment, reuse, recovery, recycling and sound environmental disposal of EEE.
- Improve the environmental performance of all those involved during the lifecycle of EEE.



All electrical and electronic products should be disposed of separately from the municipal waste stream via designated collection facilities appointed by the government or the local authorities. The correct disposal and separate collection of your old appliance will help prevent potential negative consequences for the environment and human health. It is a precondition for reuse and recycling of used electrical and electronic equipment. For more detailed information about disposal of your old appliance, please contact your city office, waste disposal service, the shop where you purchased the product or your sales representative. The statements quoted above are only fully valid for equipment which is installed and sold in the countries of the European Union and is covered by the directive 2012/19/EU. Countries outside the European Union may have other regulations regarding the disposal of electrical and electronic equipment

2.11 Data Protection and Data Security



Please note the details below with respect to protecting data and ensuring privacy.

The communication systems and servers described in this documentation process and use personal data for purposes such as call detail recording, displays, and customer data acquisition.

In Germany, the processing and use of such data is subject to various regulations, including those of the General data Protection Regulation (GDPR) and the Federal Data Protection Law (Bundesdatenschutzgesetz, BDSG). For other countries, please follow the appropriate national laws.

The aim of data protection is to protect the rights of individuals from being adversely affected by use of their personal data.

In addition, the aim of data protection is to prevent the misuse of data when it is processed and to ensure that one's own interests and the interests of other parties which need to be protected are not affected.



The customer is responsible for ensuring that the communication systems and servers are installed, operated and maintained in accordance with all applicable labor laws and regulations and all laws and regulations relating to data protection, privacy and safe labor environment.

Employees of Unify Software and Solutions GmbH & Co. KG are bound to safeguard trade secrets and personal data under the terms of the company's work rules.

In order to ensure that the statutory requirements are consistently met during service – whether on-site or remote – you should always observe the following rules. You will not only protect the interests of your and our customers, you will also avoid personal consequences.

A conscientious and responsible approach helps protect data and ensure privacy:

- Ensure that only authorized persons have access to customer data.
- Take full advantage of password assignment options; never give passwords to an unauthorized person orally or in writing.
- Ensure that no unauthorized person is able to process (store, modify, transmit, disable, delete) or use customer data in any way.
- Prevent unauthorized persons from gaining access to storage media such as backup CDs and DVDs or log printouts. This applies to service calls as well as to storage and transport.
- Ensure that storage media which are no longer required are completely destroyed. Ensure that no sensitive documents are left unprotected.
- Work closely with your customer contact; this promotes trust and reduces your workload.

Refer to the "OpenScape Business V3 Security Checklist, Planning Guide" for the measures to be taken to secure communication system.

NOTICE

It is of vital importance that security measures outlined in the Security Checklist are executed.

2.12 Markings



Hereby, the manufacturer declares that the OpenScape Business X1R is in compliance with the EU Directives 2014/30/EU (EMC), 2014/35/EU (LVD) and 2011/65/EU (RoHS).

The full text of the EU declarations of conformity are available under the subdirectory "Declarations of Conformity" at the following internet address:
<http://wiki.unify.com>



Hereby, the manufacturer declares that the OpenScape Business X1R is in compliance with the UK Electrical Equipment (Safety) Regulations 2016, UK Electromagnetic Compatibility Regulations 2016 and UK RoHS Regulations 2012.

The full text of the UK declarations of conformity are available under the subdirectory "Declarations of Conformity" at the following internet address:
<http://wiki.unify.com>

3 System description

3.1 OpenScape Business X1R

OpenScape Business X1R is a communication system which can be wall mounted, placed in the desk and mounted in a 19" rack.



Figure 1: OpenScape Business X1R

Construction data

- Dimensions (height x width x depth): approx. 43.7 mm x 436 mm x 251.5 mm
- Weight: 3.9 kg

Power Rating

- 1.4 A / 100 - 240 VAC
- 50 - 60 Hz

3.2 Boards

The HW contains the mainboard OCCSBR, plus optional modules.

3.2.1 Overview of Modules

All boards that are either built-in into the base box of an OpenScape Business communication system or that can be ordered as an expansion, are listed below by their function.

Boards within the current portfolio

These boards can be ordered separately or only in combination with a system box.

A distinction between the types of boards according to the explanation above is made.

Table 1: Central Boards and Modules

Board	Part Number	Used in	Function
CMAe	S30807-Q6957-X	X1R	Provisioning of ADPCM conversion and echo cancellation for DECT Light (integrated cordless solution)
OCCBL	S30807-Q6956-X1	X1R	Addition of one digital signal processor (DSP) for further DSP channels
OCCBH	S30807-Q6956-X2	X1R	Addition of one digital signal processor (DSP) for further DSP channels
OCCSBR	S30810-Q2965- S100 S30810-Q2965- S101	X1R	X1R mainboard
OCCSAR	S30810-Q2965- S200 S30810-Q2965- S201	X1R	X1R mainboard

Peripheral boards

No peripheral boards exist for OpenScape Business X1R. All devices are directly connected to the mainboard.

3.2.2 X1R Interfaces

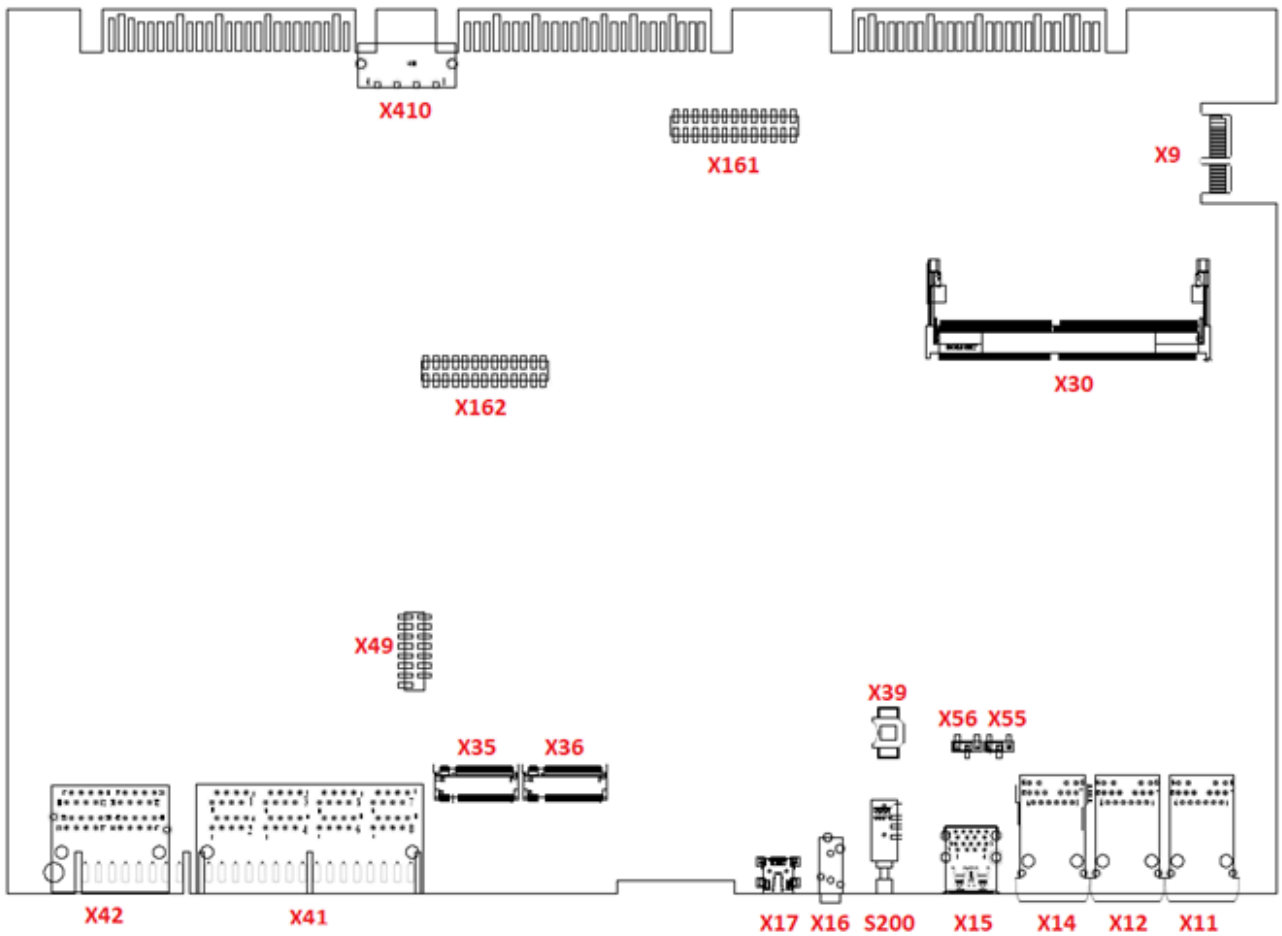

Figure 2: X1R Interfaces



Figure 3: X1R front panel interfaces

Connectors

Fire hazard due to surge voltage.

System description

Only for the $U_{P0/E}$ and a/b interfaces used for the station connection: In the case of line lengths exceeding 500 m and where the lines exit the building, the OCCSBR and OCCSAR boards must be protected by external lightning protection.

Lightning protection of this kind is known as additional primary protection. The additional primary protection is guaranteed by installing USAGs (surge arresters, gas filled) in the main distribution frame, the patch panel or at the entry point of the pipe in the building. A gas-filled surge arrester with 230 V nominal voltage is switched to ground from each wire that is to be protected.

- X41 = 8 $U_{P0/E}$ interfaces (edge connectors)

The following can be connected

- $U_{P0/E}$ phones and
- DECT base stations for DECT Light (integrated cordless solution).

To connect the base stations, the $U_{P0/E}$ interfaces 2 through 8 must be used.

- X42 = 4 a/b interfaces (edge connectors)

Analog phones and devices (fax, modem, etc.) can be connected.

The a/b interfaces supply a ring voltage of approx. 65 Vrms.

Calling name identification presentation (CLIP) is supported.

The connection of external extensions is not possible.

- X 17, Service = USB device port, Mini B jack (USB 1.1, up to 2 Mbit/s)

To connect a PC for service and diagnostic purposes.

- X16, Audio In = Analog audio in port, 3.5 mm audio jack

To connect an external audio device for Music on Hold.

- X15 USB = 2x USB host ports, Standard A jacks for connecting an external hard disk or USB stick for backups and software upgrades or recovery installations.

- OCCSBR and OCCSAR: 2x USB 3.0

- X11, X12, X14 = 2 Ethernet (10/100/1000 BaseT) ports (RJ45 jacks)

Two LEDs indicate the current status of each Ethernet interface.



It is recommended to operate X14 and X12 interface with 100 Mbps at least to ensure the transmission quality of VoIP traffic.

Table 2: OCCSBR and OCCSAR– LEDs for Indicating the Ethernet Interface Status

Left LED	Right LED	Description
off	Blink green light	Activity 1000 Mbps
Blink orange light	Blink green light	Activity 100 Mbps
Blink orange light	off	Activity 10 Mbps
off	off	No link, no activity
off	Solid green light	Link 1000 Mbps

Left LED	Right LED	Description
Solid orange light	Solid green light	Link 100 Mbps
Solid orange light	off	Link 10 Mbps

- X11, ADMIN = Ethernet port, RJ45 jack (10/100/1000 BaseT) ports
- X12, LAN= Ethernet port, RJ45 jack (10/100/1000 BaseT) ports

For linking into the LAN infrastructure of the customer, for connecting a WLAN Access Point, an additional LAN switch of the direct connection of an IP phone or PC client.

- X14 WAN = Ethernet port, RJ45 jack (10/100/1000 BaseT)

To connect to an ITSP, for example, using DSL (PPOE or PPTP protocol). The WAN can be connected to the DSL modem either directly or via a router.



All Ethernet ports support only Full Duplex mode.

- X55 = Clear RTC - 3 pin connector strip to reset the real time clock (RTC).

Jumper must be set on pins 1-2 for normal operation (factory delivery default). Settings jumper on pins 2-3 for 10 seconds clears the RTC.



After an RTC reset of a mainboard which is operated in a customer system, the system time needs to be actualized afterwards using the OpenScape Business Assistant (WBM). Otherwise problems may occur with the system licensing.

- X56 = Clear CMOS - 3 pin connector strip to reset the CMOS memory of the board.

Jumper must be set on pins 1-2 for normal operation (factory delivery default). Setting jumper on pins 2-3 for 10 seconds clears the CMOS memory.

Storage Cards

The following storage cards and connectors are used depending on the application.

NOTICE

When mounting the SSD storage cards on the mainboard, make sure that the mounting screw is only slightly tightened (max. 0.25 Nm) to avoid damaging the printed circuit board.

- 1) M.2 SATA SSD containing the system SW must be inserted in connector X35. This SSD is mandatory for the operation of the OCCMB board/ system.
- 2) M.2 NVMe SSD for storing the multimedia data of the embedded applications. This SSD is optional. Its usage depends on the embedded applications that are operated within the system. The NVMe SSD must be inserted in connector X36. The minimum storage capacity is 120GB.

Subboards

The following optional subboards can be used depending on the application.

NOTICE Place the mainboard on a flat surface before inserting a subboard. Otherwise you may damage the mainboard.

The spacing bolts supplied guarantee the correct positioning of a subboard, so you should always mount them.

1) CMAe (Clock Module with ADPCM enhanced)

CMAe is used in combination with DECT Light (integrated cordless solution). It provides the functions for ADPCM conversion and echo cancellation. If no CMAe is installed no echo cancellation is supported and ADPCM is performed directly by the base station.

The subboard is plugged into the X161 and X162 connector strips on the OCCSBR and OCCSAR boards. The DECT base stations must be connected to the U_{P0/E} interfaces 2 through 8 of the mainboard.

2) OCCBL and OCCBH (Open Core Channel Booster)

Connections between IP and TDM phone or trunks connection requires DSP (Digital Signal Processor) channel. If the number of DSPs provided on the central control board is insufficient, an OCCBL/OCCBH subboard can be used. OCCBL/OCCBH provides up to 40/120 additional DSP channels.

The OCCBL/OCCBH subboard has a PCI-E jack which is plugged into the edge connector X9 of the mainboard.

Audio In Jacks

The 3.5 mm Audio In jack (X16) at the front panel offers the connection to external audio devices for Music on Hold or announcements. Connection is done by a 3.5 mm mono or stereo plug.

- Maximum input level: 3Vpp
- Input Impedance: 60 kOhm

Reset Switch

The board includes a reset switch with the following functions.

Table 3: OCCSBR and OCCSAR - Functions of the Reset Switch

Reset switch is pressed	Result	Info LED
< 5 s	The communication system performs a controlled restart (similar to pressing the Reset button on a PC). The communication system will be operational again after the startup.	<5s: Purple 1 Hz
> 5 s and < 10 s	A controlled shutdown of the communication system is performed.	>5s and <10s: Orange 1 Hz



















Reset switch is pressed	Result	Info LED
> 10 s	A reload is initiated on the communication system. The communication system reverts to the initial (default) state following startup. All country and customer-specific settings are lost (system country code = Germany). Country- and customerspecific data backups can be reloaded once the basic settings have been configured.	>10s: Solid Purple

Immediately after releasing the reset switch, the selected function (restart, shutdown or reload) is executed.





























LEDs

The board features two LEDs that indicate the operating states.

Table 4: OCCSBR and OCCSAR - LED Statuses and their Meanings

RUN LED	INFO LED	Description
 Off	 Off	System powered off
 Off	 Red	Default after power on (typically < 1 second)
 Blue flashing 1Hz	 Red	Battery and CMOS checking
 Off	 Blue flashing 1Hz	BIOS update
 Blue	 off	BIOS running
 Blue	 Blue flashing 1Hz	RAM initialization
 Blue	 Red	RAM not detected 
 Blue	 Red flashing 8Hz	BIOS critical error 

System description

RUN LED	INFO LED	Description
 Blue flashing 8Hz	 Off	Boot device missing 
 Green	 Off	BIOS boot completed/ Linux startup continues
 Green	 Red	Linux startup not possible 
 Green	 Blue flashing 8Hz	FPGA update in progress
 Green	 Green	Linux startup has completed/ System starts
 Green	 Blue	DSP initialization
 Green flashing 3 x 100/500ms	 Green	Telephony starts
 Green flashing 3 x 100/500ms	 Off	Telephony is synchronized
 Green flashing 1 Hz	 Off	System running in normal operating state
 Not relevant	 Purple flashing 1Hz	System restart requested
 Not relevant	 Purple	System reload requested
 Not relevant	 Orange flashing 1Hz	System shutdown requested
 off	 Red	System shutdown has been completed. System can be disconnected from the power supply.

Pin Assignments

Table 5: OCCSBR and OCCSAR - Pin Assignments of the X41 Connector (U_{PO/E} Interfaces)

-	Pin 4	Pin 5
Connecto	Signal	Signal
1	1b	1a
2	2b	2a
3	3b	3a
4	4b	4a
5	5b	5a
6	6b	6a
7	7b	7a
8	8b	8a

Table 6: OCCSBR and OCCSAR - Pin Assignments of the X42 Connector (a/b Interfaces)

-	Pin 4	Pin 5
Connecto	Signal	Signal
1	1b	1a
2	2b	2a
3	3b	3a
4	4b	4a

3.2.3 CMAe

CMAe (Clock Module with ADPCM enhanced) are optional subboards for the central control boards OCCSBR and OCCSAR (OpenScape X1R) and OCCMR, OCCMBR, OCCMAR (OpenScape Business X5R).

CMAe are used in combination with DECT Light (integrated cordless solution). The subboard provides the functions for ADPCM conversion and echo cancellation (48 channels for CMAe). Up to four calls can be conducted per DECT base station. Up to seven DECT base stations can be connected to the U_{PO/E} interfaces of the central control boards.



If no CMAe is installed, a maximum of two calls can be conducted per base station. In this case, ADPCM conversion is performed directly by the DECT base station, but echo cancellation is not directly supported. In case that echo cancellation is required a CMAe subboard is needed.

Board Variants and their Use

Board	Part Number	Used in		Maximum number
		Communication system	Country	
CMAe	S30807-Q6957-X	OpenScape Business X1R	CE	1

CMAe is plugged into the following connector strips on the mainboards:

- OCCSBR and OCCSAR: connector strips X161 and X162 (see [X1R Interfaces](#) on page 27)

 In the default factory state, the CMAe subboard has two spacing bolts inserted to ensure the correct positioning of the subboard on the mainboard.

Figure



Figure 4: CMAe subboard

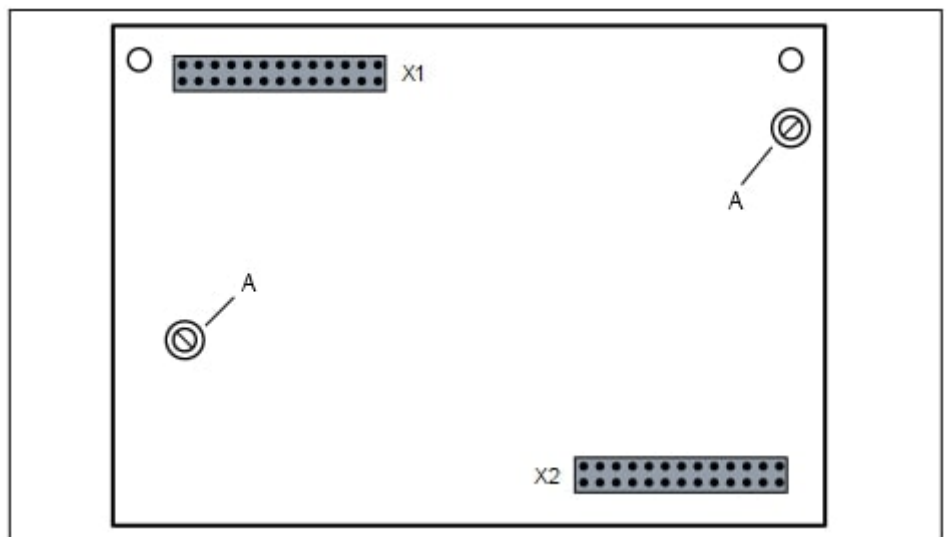

Figure 5: CMAe - Component side with inserted spacing bolts (A)

3.2.4 OCCBL and OCCBH

If the number of signal digital processors processor (DSP) channels provided by the mainboard of the system is insufficient, additional DSP channels can be provided by inserting an OCCB subboard

- OCCBL: provides up to 40 additional DSP channels (gateway channels).
- OCCBH: provides up to 120 DSP channels (gateway channels).



System software version V3 or higher is required for its operation.

Board Variants and their Use

Board	Part Number	Used in			Maximum number
		Communica system	Mainboard	Country	
OCCBL	S30807-Q6956-X1	OpenScope Business X1R/X1RA	OCCSBR and OCCSAR	ROW	1
OCCBH	S30807-Q6956-X2	OpenScope Business X1R/X1RA	OCCSBR and OCCSAR	ROW	1

The OCCBL and OCCBH subboards have a PCI-E jack that is plugged in the same way into the associated edge connector of the mainboard:

- OCCSBR and OCCSAR: edge connector X9, see [How to Install OCCBL or OCCBH on OCCSBR or OCCSAR](#) on page 51



In the default factory state, the subboard has two spacing bolts inserted to ensure the correct positioning of the subboard on the mainboard.

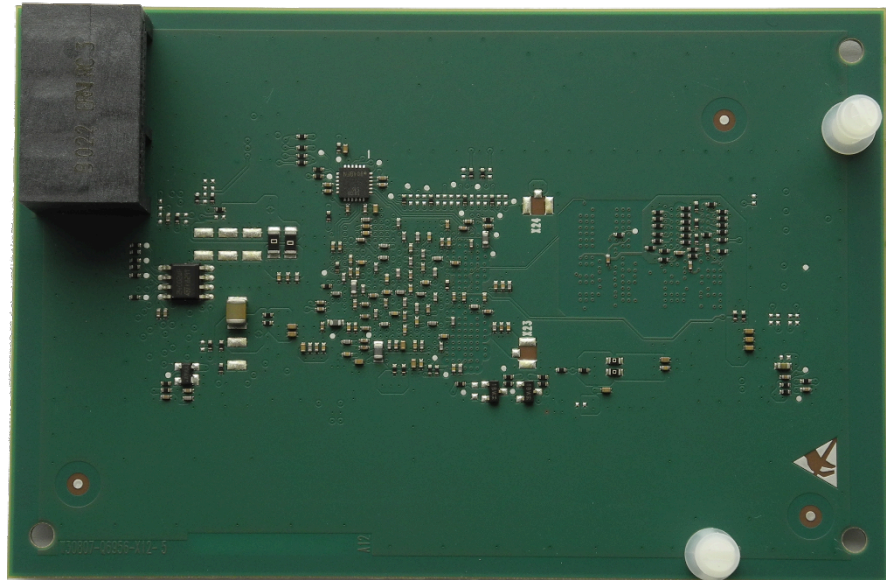

Figure 6: Example OCCBL - Rear side with inserted spacing bolts

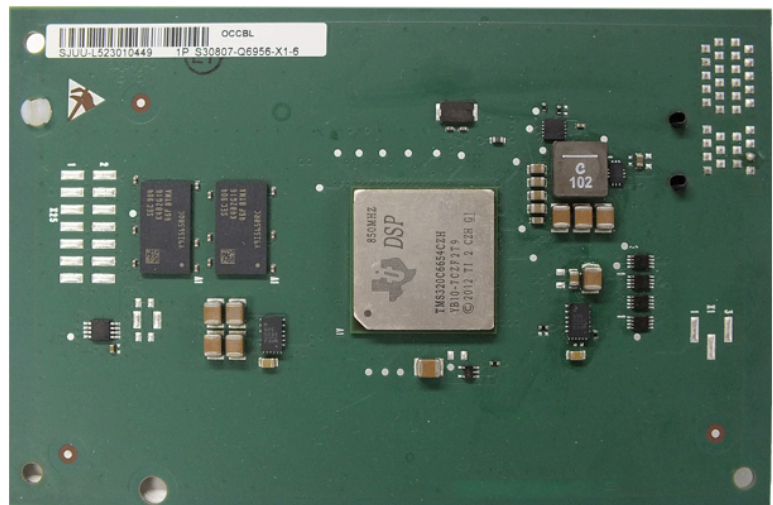

Figure 7: Example OCCBL - Top view

4 Preparing for the Installation of OpenScape Business X1R

Before the OpenScape Business X1R communication system can be set up and put into operation for the first time, a suitable installation site must be found, and some preparatory activities must be performed.

4.1 Prerequisites for the Installation

A number of different tools and resources are required for the installation of OpenScape Business X1R. Certain requirements must be observed when selecting the installation site.

Warning: Only authorized service personnel should install and start up the communication system.

Tools and Resources

The following tools and resources are required:

- Diagonal cutting pliers, telephone pliers, wire stripper, flat-nosed pliers
- Slotted screwdriver set
- Phillips or Pozidriv screwdriver set
- TORX screwdriver set
- Electric drill, hammer
- Level, tape measure
- Digital multimeter for testing ground connections and partial voltages

Prerequisites for Selecting the Installation Site

Make sure that the installation site meets the following requirements:

- The following minimum clearances to the housing must be maintained to guarantee sufficient ventilation for the communication system:
 - Left side: 10 cm
 - Right side: 10 cm
- The power cable connector must be readily accessible for quick disconnection from the power source at any time.
- Do not expose the communication system (and the 19" rack) to direct sources of heat (for example, direct sunlight, radiators, etc).
- Do not expose the communication system (and the 19" rack) to extremely dusty environments.
- Avoid any contact between the communication system (and the 19 " rack) and chemicals.
- Avoid all condensation of humidity on or in the communication system during operation under all circumstances.

The communication system must be completely dry before putting it into service.

- Avoid standard carpeting, as it tends to produce electrostatic charges.
- Note the environmental and mechanical conditions for operating the communication system.
- Allow sufficient space for a main distribution frame or other additional equipment.

4.2 Preparatory Steps

Unpack and check the supplied components before starting the installation. The housing cover must be removed.

4.2.1 How to Unpack the Components

Proceed as follows to unpack the communication system and parts supplied:

Step by Step

- 1) Open the packaging without damaging the contents.
- 2) Check the components delivered against the packing slip to make sure nothing is missing.
- 3) Report any shipping damage to the address indicated on the packing slip.
- 4) All packaging material must be disposed of in compliance with the relevant country-specific requirements.

⚠ DANGER Risk of electric shock through contact with live wires!

Only use communication systems, tools and equipment which are in perfect condition. Do not use equipment with visible damage.

4.2.2 How to open the X1R

⚠ DANGER Risk of electric shock through contact with live wires!

Make sure that the communication system is de-energized.

Step by Step

- 1) Disconnect the power plug of the communication system.

2) Remove the 8 screws of the top cover.



3) Lift the cover slightly up to release it from the lock position, then slide the cover toward the front of the chassis.



4) Lift the cover over the chassis.

5 Installing the Hardware for OpenScape Business X1R

This section covers the standard installation procedure for the OpenScape Business X1R

Mounting material is included in the packaging:



Figure 8: Mounting Kit material (components)

⚠ WARNING

Risk of electric shock through contact with live wires!

- Work on the housing must only be performed in the de-energized state.
- Before starting any work, make sure that all circuits are de-energized. Never take it for granted that all circuits have reliably been disconnected from the power supply when a fuse or a main switch has been switched off.

5.1 Type of Installation

The OpenScape Business X1R communication systems can be mounted in a 19" rack, on a wall or as a standalone unit (desktop operation).

5.1.1 How to Mount the Communication System to a Wall

Prerequisites

The prerequisites for selecting the installation site were taken into account (see [Prerequisites for the Installation](#) on page 37).

⚠ WARNING **Maximum mounting height**

The mounting of the OpenScape Business X1R is not allowed over 2m. Please provide the screws (diameter min. 4 mm) and dowels for fixing the OpenScape Business X1R to the wall, depending on the condition of the wall.

Step by Step

- 1) Hang the communication system on the wall and draw a minimum of two holes per side according to the mounting holes of the brackets.
- 2) Drill those holes for the wall anchors.
- 3) Insert the wall anchor into each drilled hole (The plastic wall anchor and screw for it are not included).
- 4) Align the communication system on the mounting hole of the brackets and screw it.
- 5) Tighten all screws.



Figure 9: Brackets to fix on wall



Figure 10: Mounting components (wall anchor/screw) for wall not included

5.1.2 How to Mount the Communication System to a Rack

Step by Step

- 1) Fix the brackets on both sides of the housing by screwing the mounting screws.
- 2) Tighten all screws.
- 3) Positioning the housing on the rack.
- 4) Screwing using the holes on the brackets to align it (the mounting components for fixation on the rack are not included).

5) Tighten all screws.



Figure 11: Brackets to fix on vertical rail



Figure 12: Example – 19" fixation (vertical rail)



Figure 13: Mounting components for 19" fixation (not included)

5.1.3 How to Mount the Communication System as a Desk System

Step by Step

Fix the rubber foot on the bottom part of the housing (4x included on the mounting material). Use the marks on the sheet metal to help you during positioning/fixation.



Figure 14: Mounting Kit material (components)

5.2 Protective Grounding

The protective grounding provides a secure connection to the ground potential to protect against dangerously high touch voltages in the event of a malfunction.

⚠ WARNING Risk of electric shock through contact with live wires!

- Use separate ground wires to provide protective grounding for the OpenScape Business X1R and possibly any main distribution frames being used. Connect your communication system and your main distribution frame to the ground wire before starting up the system and connecting telephones and lines.
- Make sure that the ground wires laid are protected and strain-relieved.

⚠ WARNING Assembly of Protection Ground Terminal

5.2.1 How to Check the Grounding

Prerequisites

The communication system is **not yet** connected to the low-voltage network via the power cable.

The communication system and the main distribution frame have been properly grounded using separate ground wires.

Run the following test before startup to make sure that the protective grounding for the communication system and the MDF (if any) is working properly.

Step by Step

- 1) Check the ohmic resistance of the separate ground connection to the communication system:

The measurement is taken between the ground contact of a grounded power outlet of the home installation (where the communication system is connected) and the housing of the communication system.

- 2) If a main distribution frame is used, check the ohmic resistance of the separate ground connections to the main distribution frame.

The measurement is taken between the ground contact of a grounded power outlet of the home installation (where the communication system is connected) and the housing of the main distribution frame.

The result (reference value) of a measurement must be significantly less than 10 Ohms.

If you obtain some other results, contact a qualified electrician. The electrician will need to check the equipotential bonding of the domestic installation and ensure the low resistance grounding (ohmage) of the earthing conductors.

5.3 WAN, LAN and Admin Port

OpenScape Business X1R offers three Ethernet ports for WAN, LAN and Admin connections via 8-pin RJ45 sockets, for example, to connect to an Internet router.

5.3.1 How to Set up a WAN, LAN or Admin Connection

Prerequisites

CAUTION Fire hazard

To reduce the risk of fire, you may only use communication cables with a conductor diameter of at least 0.4mm (AWG 26) or larger. The recommended cable is a shielded Cat.5 cable (multi-element cables characterized up to 100 MHz - horizontal and building backbone cables as per EN 50288). These are specified with a conductor diameter from 0.4 mm to 0.8 mm.

At least one free WAN or LAN port is available.

Step by Step

Connect the desired WAN, LAN or Admin port to the device to be connected (LAN switch, Internet router, DSL modem, etc.).

5.4 Connecting Phones and Devices

Different types of phones and devices can be connected to the OpenScope Business X1R. The connection is made directly at the board.

You can select the connection(s) required for your communication system from the following options:

- Connection of U_{P0/E} phones
- Connection of analog devices

U_{P0/E} Phones and Analog Devices

For U_{P0/E} telephones and analog devices, RJ45 connectors are inserted directly in one of the 8 U_{P0/E} connectors of the system.

5.4.1 How to Connect U_{P0/E} Phones

Prerequisites

At least one free U_{P0/E} interface is available on an OCCSBR mainboard.

⚠ WARNING Risk of electric shock through contact with live wires!

Use separate ground wires to provide protective grounding for your communication system and any main distribution frames used before connecting telephones and lines.

⚠ CAUTION Fire hazard

To reduce the risk of fire, you may only use communication cables with a conductor diameter of at least 0.4mm (AWG 26) or larger.

NOTICE Fire hazard due to surge voltage

In the case of line lengths exceeding 500 m and where the lines exit the building, the OCCSBR mainboard must be protected by external lightning protection. Lightning protection of this kind is known as additional primary protection. The additional primary protection is guaranteed by installing ÜSAGs (surge arresters, gas filled) in the patch panel or at the entry point of the pipe in the building. A gas-filled surge arrester with 230 V nominal voltage is switched to ground from each wire that is to be protected.

Step by Step

- 1) Insert the plug of the connection cable into the U_{P0/E} telephone.

- 2) Secure the wires of the connection cable to the plug connector and insert it into one of the X41 connectors of the U_{P0/E} interfaces.



Refer to the installation instructions of the phone to be connected.

- 3) If present, connect any further U_{P0/E} phones to the communication system by the same method.

5.4.2 How to Connect Analog Devices

Prerequisites

At least one free analog interface is available on an OCCSBR / OCCSAR mainboard.

⚠ WARNING

Risk of electric shock through contact with live wires!

Use separate ground wires to provide protective grounding for your communication system and any main distribution frames used before connecting telephones and lines.

⚠ CAUTION

Fire hazard

To reduce the risk of fire, you may only use communication cables with a conductor diameter of at least 0.4mm (AWG 26) or larger.

NOTICE

Fire hazard due to surge voltage

In the case of line lengths exceeding 500 m and where the lines exit the building, the OCCSBR / OCCSAR mainboard must be protected by external lightning protection. Lightning protection of this kind is known as additional primary protection. The additional primary protection is guaranteed by installing ÜSAGs (surge arresters, gas filled) in the patch panel or at the entry point of the pipe in the building. A gas-filled surge arrester with 230 V nominal voltage is switched to ground from each wire that is to be protected.

Step by Step

- 1) Insert the plug of the connection cable into the analog device (telephone, fax, modem, TFE-S, etc.).
- 2) Secure the wires of the connection cable to the plug connector and insert it into the X42 connector of the a/b interfaces.



Refer to the installation instructions of the phone/device to be connected.

- 3) If present, connect any further analog telephones to the communication system by the same method.

5.5 Closing Activities



During the initial startup of the communication system, the charge state of the battery on the mainboard is undefined. To achieve an adequate charge state, the system must remain connected to the mains for at least 2 days. If the system is disconnected from the mains power supply, the battery may be insufficiently charged and could potentially cause the activation period to be blocked due to time manipulation.

5.5.1 How to Install a M.2 SATA / NVMe SSD on OCCSBR or OCCSAR

The M.2 SATA SSD contains the OpenScape Business communication software and must be inserted before starting up the communication system. The NVMe SSD is optional and contains media data for UC Suite, further trace capabilities and local backup options.

⚠ DANGER

Risk of electric shock through contact with live wires!

Make sure that the communication system is de-energized. Do not remove the Power Supply cover.

Step by Step

- 1) Open the communication system as described in [How to open the X1R](#) on page 38.

- 2) Remove the pre-assembled screw on the M.2 SATA slot (1) of the OCCSBR / OSSCAR mainboard.

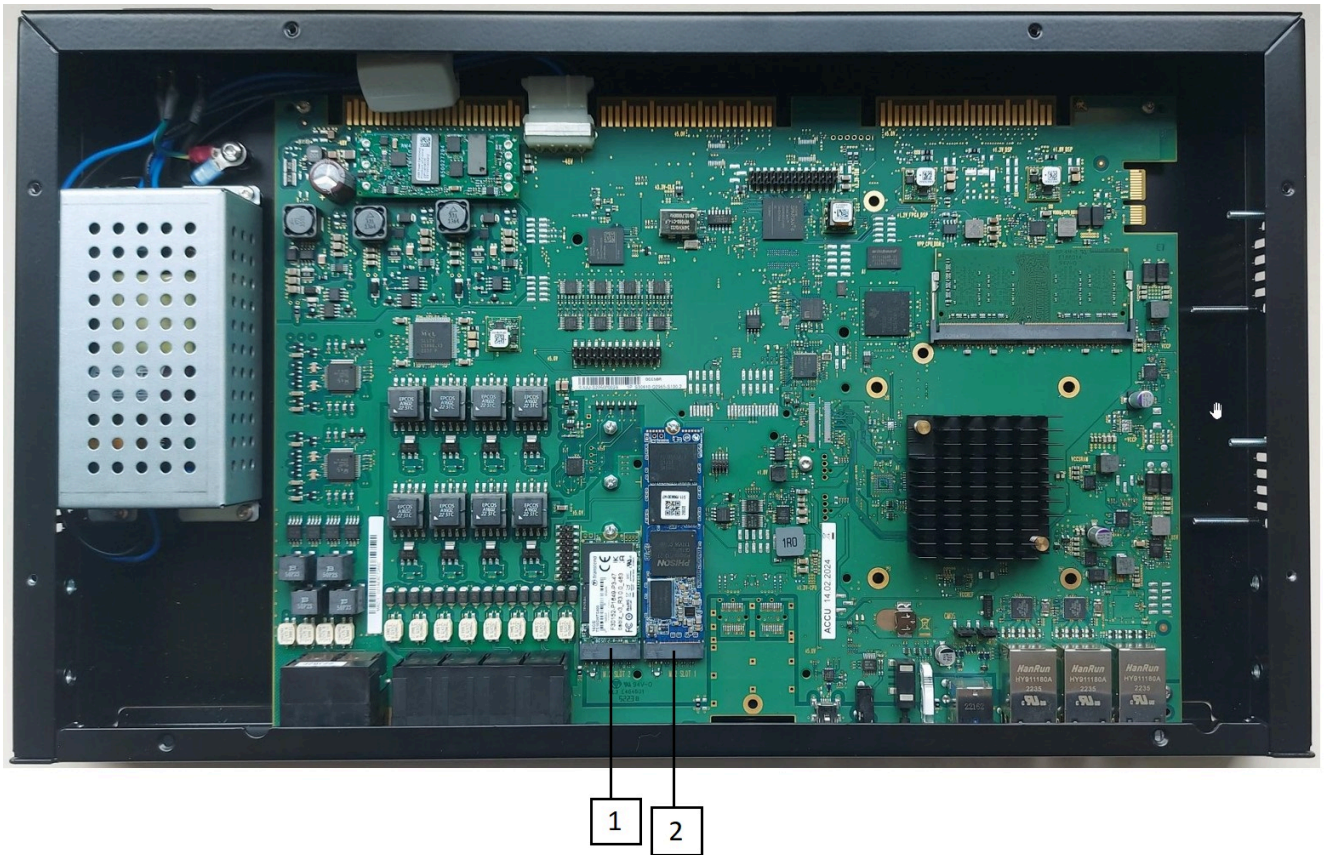

- 3) Insert the M.2 SATA SSD into the M.2 SATA slot (1) of the mainboard.
- 4) Optional: Remove the pre-assembled screw on the NVMe slot (2) of the OCCSBR / OCCSAR mainboard.
- 5) Optional: Insert the NVMe SSD into the NVMe slot (2) of the mainboard.
- 6) Fasten the M.2 SATA SSD (optional NVMe SSD) to the mainboard with the screw you removed before.
- 7) Slide the top cover of the communication system back in place and screw everything back.
- 8) Place the communication system back into operation.

5.5.2 How to Install CMAe

⚠ DANGER

Risk of electric shock through contact with live wires!

Make sure that the communication system is de-energized. Do not remove the Power Supply cover.

Step by Step

- 1) Disconnect the power plug of the communication system.
- 2) Remove the top cover screws.

Installing the Hardware for OpenScope Business X1R

- 3) Remove the top cover from the system.
- 4) Plug the CMAe subboard (with component side facing downwards) into the following connector strips on the mainboard. Make sure that the two spacing bolts are plugged into the appropriate holes on the mainboard.
 - OCCSBR and OCCSAR: connector strips X161 and X162.

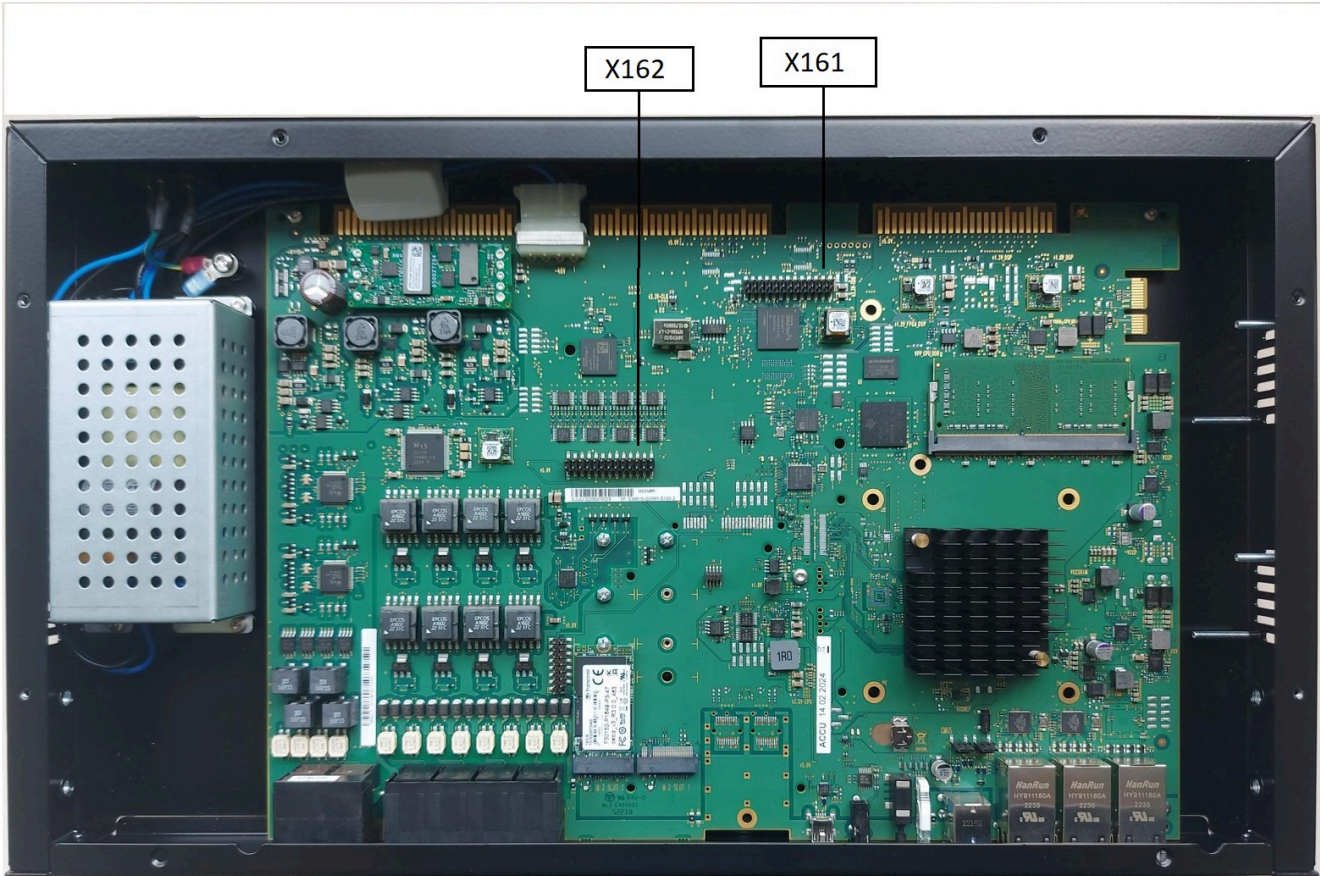

Figure 15: X161 and X162 connector strips on the mainboard



In the default factory state, the CMAe subboard already has the spacing bolts inserted.

- 5) Place back the left housing cover and close it.

- 6) Place the communication system back into operation.

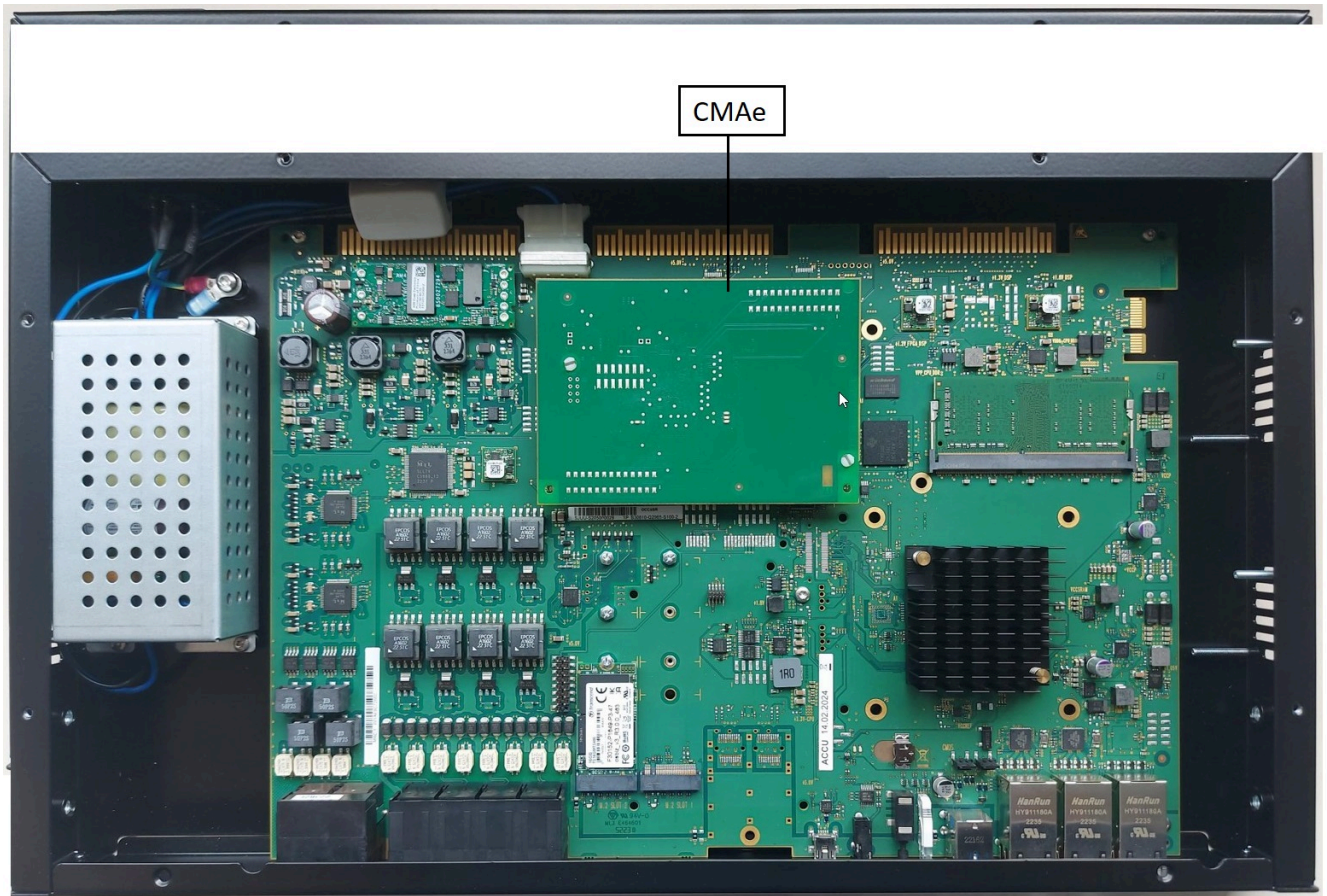

Figure 16: CMAe board

5.5.3 How to Install OCCBL or OCCBH on OCCSBR or OCCSAR

⚠ DANGER

Risk of electric shock through contact with live wires!

Disconnect the power plug of the X1R communication system before opening the housing. Do not remove the Power Supply cover.

Step by Step

- 1) Disconnect the power plug of the communication system.
- 2) Remove the top cover screws.
- 3) Remove the top cover from the system.

Installing the Hardware for OpenScape Business X1R

- 4) Insert the PCI-E connector X22 of the OCCBL subboard (rear side down) onto the X9 edge connector of the mainboard. Make sure that the two spacing bolts are plugged into the appropriate holes on the mainboard.



In the default factory state, the OCCBL subboard already has the spacing bolts inserted.

In case metallic and plastic spacing bolts are provided with OCCBL subboard, use only the plastic ones to plug OCCBL into the holes of the mainboard.

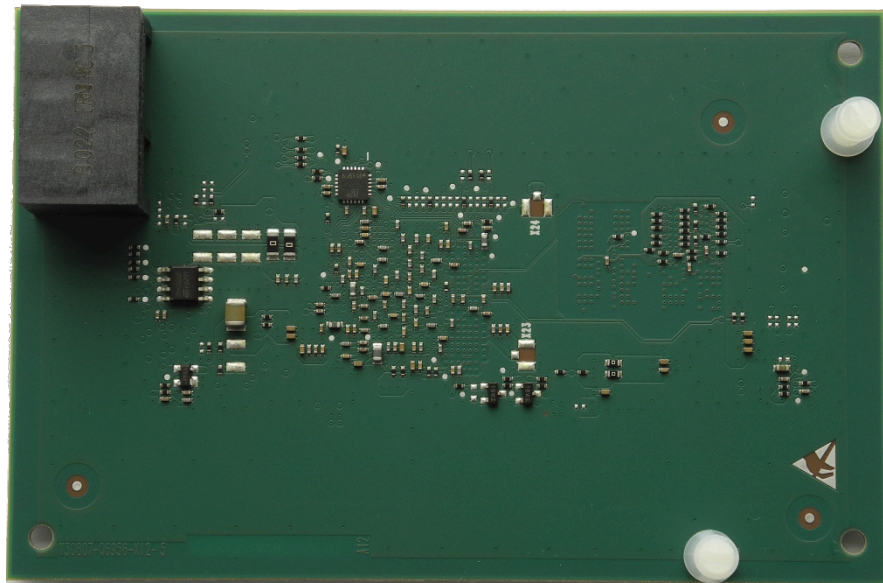

Figure 17: Example OCCBL – Rear side with inserted spacing bolts

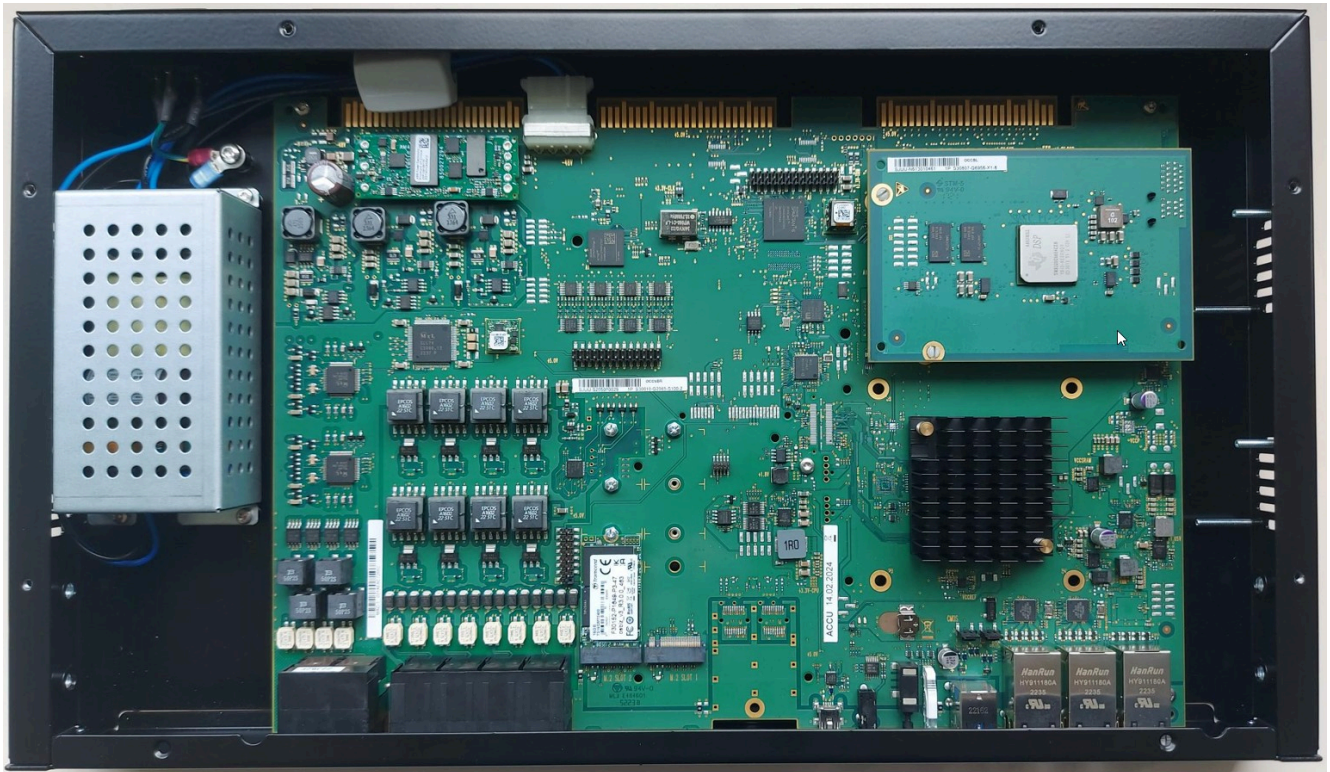

Figure 18: Example OCCBL – Rear side with inserted spacing bolts

- 5) Slide the top cover back in place and screw everything back.
- 6) Place the communication system back into operation.

5.5.4 How to Perform a Visual Inspection

Before starting up the communication system, you must perform a visual inspection of the hardware, cables, and the power supply.

Prerequisites

⚠ DANGER Risk of electric shock through contact with live wires!

Make sure that the communication system is de-energized. Do not remove the Power Supply cover.

NOTICE Always wear an antistatic wristband when handling boards.

The ESD measures for protecting electrostatically sensitive devices must be observed and followed.

The housing cover of the communication system is not mounted.

Step by Step

- 1) Disconnect all power supply circuits of the communication system.
- 2) Verify that the M.2 SATA SSD card is properly seated.
- 3) Check that all boards are secure.
- 4) Ensure that all connection cables have been correctly laid and secured. Is there any risk of tripping over a cable, for example?

If required, make sure that the connection cables are properly installed.

- 5) Check that a separate ground wire is connected to the communication system's ground terminal. (Only applicable for systems with OCCSBR / OCCSAR mainboards.)

If required, ground the communication system using a separate ground wire (see [Protective Grounding \(PE\)](#) on page 15)

- 6) Check whether the nominal voltage of the mains power supply corresponds to the nominal voltage of the communication system (type plate).

Next steps

Close the housing cover of the communication system.

5.5.5 How to Close the Communication System

Step by Step

- 1) If you need access to the mainboard, open the top cover by unscrewing the 8 screws.
For more information, see [How to open the X1R](#) on page 38.
- 2) Slide the top cover back in place and screw everything back.

5.5.6 How to Connect the System to the Mains

Step by Step

Plug the power cord into the socket of the power supply. The communication system boots up.

NOTICE

Leave the system connected to the mains for at least 2 days so that the mainboard battery is adequately charged. If the charge state is insufficient, it is possible that repeated booting of the system could cause the activation period to be blocked due to time manipulation.

6 Initial Setup for OpenScape Business X1R

This chapter describes the initial setup of OpenScape Business X1R. The communication system and its components are integrated into an existing infrastructure consisting of a customer LAN and a TDM telephony network. Internet access and the trunk connection are set up and the connected stations are configured.

The initial setup of OpenScape Business X1R (i.e., the communication system) is carried out using the OpenScape Business Assistant administration program (web-based management, also called WBM).

The standard initial setup of commonly used components is described here. The specific installation steps depend on the communication system and the components involved. During the initial setup, you may need to choose between multiple options in some places or even skip some configurations entirely. It is also possible that the installation steps described here do not appear in your communication system.

The detailed configurations of features not covered by the standard initial setup are described in subsequent chapters.

The initial setup requires the creation of an IP address scheme and a dial plan.

The most important installation steps are as follows:

- IP addresses and DHCP settings
- Country and Time Settings
- System Phone Numbers and Networking
- Internet access
- Internet telephony
- Station configuration
- Licensing
- Data backup

6.1 Prerequisites for the Initial Installation

Meeting the prerequisites for the initial installation ensures the proper operation of the communication system.

General

Depending on the existing hardware (boards, phones, ...) and infrastructure, the following general conditions apply:

- The infrastructure (LAN, TDM telephony network) is available and usable.
- The hardware is installed and connected properly.
- The communication system has not yet been connected to the LAN.
- Internet access is available through an Internet Service Provider.
- An IP address scheme exists and is known.
- A dial plan (also called a numbering plan) is present and known.

Admin PC

The following prerequisites must be fulfilled for the Administration PC (Admin PC) that is used for initially setting up the system and for the subsequent administration of the communication system:

Initial Setup for OpenScape Business X1R

Components

- Network interface:
The admin PC requires an available LAN port.
- Operating system:
Configuring the communication system with the Manager E is only possible on a Windows operating system.
WBM configuration, however, is browser-based and therefore platform-independent.
- Web browser:
The following web browsers are supported:
 - Microsoft Edge
 - Mozilla Firefox Version 17 and later.
 - Google Chrome
If an older version of the Web browser is installed, you will need to install an up-to-date version before you can start setting up the system.

6.2 Components

The various components of the installation example are described and outlined below.

The installation example includes the following components:

- OpenScape Business X1R
The communication system is integrated in the existing customer LAN via the LAN interface.
- Admin PC
The admin PC is also connected to the communication system via a LAN interface.
- IP stations (IP clients)
The IP stations (IP system phones, client PCs, WLAN Access Points, etc.) are integrated in the LAN via one or more switches.
- U_{P0/E} stations
U_{P0/E} stations are connected directly to the communication system.
- Analog stations
Analog stations (e.g., analog fax devices) are connected directly to the communication system.
- DECT stations
DECT stations are logged on to the communication system via a base station.

The IP clients receive their IP addresses dynamically from an internal or external DHCP server (e.g., an Internet router).

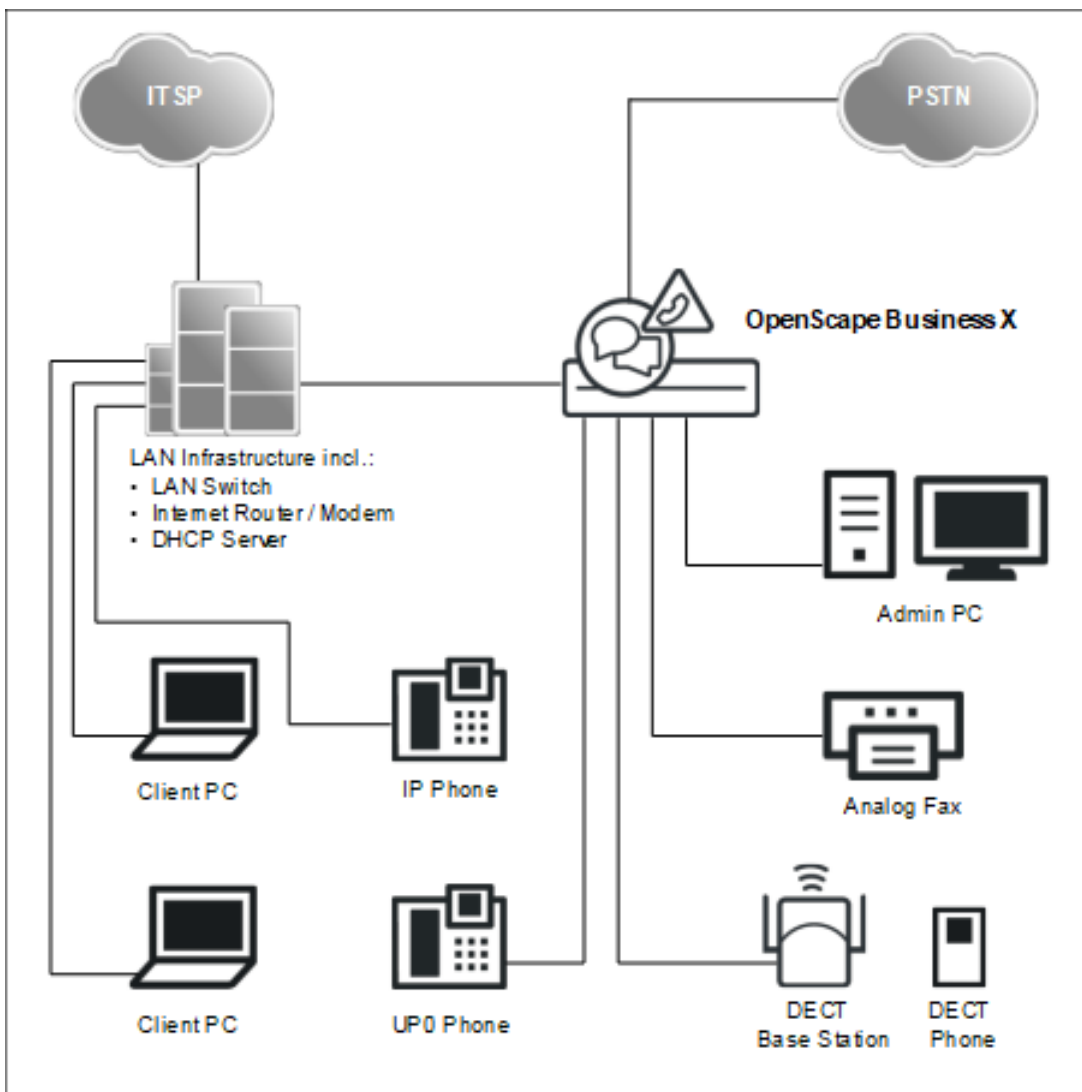

6.3 Dial Plan

A dial plan is a list of all phone numbers available in the communication system. It includes, among other things, the internal call numbers, DID numbers and group call numbers.

Default Dial Plan

The internal call numbers are preassigned default values. These values can be adapted to suit individual requirements as needed (e.g., to create individual dial plans).

Extract from the default dial plan:

Type of call numbers	X1R
Internal station numbers	11-30
User direct inward dialing numbers	11-30

Type of call numbers	X1R
Trunk station number	700-703
Seizure codes (external codes):	0 = World / 9 = USA
Trk. Grp 1	
Rte. 8 (UC Suite)	-
Trk. Grp 12-15 (trunk: ITSP)	not preset
Rte. 16 (Networking)	not preset
Call number for remote access	not preset
Call number for voicemail	351
UC Smart	-
UC Suite	

Individual Dial Plan

An individual dial plan can be imported via an XML file during basic configuration.

The XML file contains several tabs. Besides the names and phone numbers of subscribers, the "Customer" tab also includes additional subscriber data such as the subscriber types and e-mail addresses of the subscribers.

A sample XML file with the appropriate explanations can be found in the WBM under **Service Center > Documents > CSV Templates**. You can also use the XML file stored there as a template for your data. It can be edited with Microsoft Excel, for example.

6.4 IP Address Scheme

An IP address scheme is a definition of how the IP addresses are used in the customer LAN. It includes the IP addresses of PCs, servers, Internet routers, IP phones, the communication system, etc.

To provide a better overview of the assignment of IP addresses, an IP address scheme should be created.

Example of an IP address scheme with the IP address range 192.168.1." - x:

IP address range	Clients
192.168.1.1 to 192.168.1.19	Clients with a fixed IP address:
192.168.1.1	Internet router (gateway)
192.168.1.2	Communication system
192.168.1.10	E-mail server
192.168.1.50 to 192.168.1.254	Client PCs & IP phones, also the IP address range of the DHCP server; IP addresses are assigned automatically to the clients

The following IP address ranges are internally reserved and must not be used:

Connected IP address ranges	Description
10.0.0.1; 10.0.0.2	Reserved for the license server
10.186.237.65; 10.186.237.66	Reserved for remote ISDN
192.168.3.2	Internal IP address of the communication system
192.168.2.1	IP address of the Admin port

This list can also be found in the WBM under **Service Center > Diagnostics > Status > Overview of IP Addresses**.

Expanding the netmask when using the default network segment

Both the internal IP address of the communication system and the IP address of the Admin port must not be in the same network segment as the IP address of the communication system.

Default network segment configuration:

- 192.168.1.2: IP address of the communication system
- 255.255.255.0: Netmask
- 192.168.3.2: Internal IP address of the communication system
- 192.168.2.1: IP address of the Admin port

If the netmask when using the default network segment of 255.255.255.0 was expanded to 255.255.0.0, for example, then the above IP addresses need to be changed:

Example of a modified configuration:

- 192.168.1.2: IP address of the communication system
- 255.255.0.0: Netmask
- 192.169.3.2: Internal IP address of the communication system

The change is made via **Expert mode > Telephony Server > Payload > HW Modules > Edit DSP Settings**

- 192.170.2.1: IP address of the Admin port

The change is made via **Expert mode > Telephony Server > Network Interfaces > Mainboard > Admin**

6.5 Initial Startup

Initial startup includes starting up the communication system, connecting and configuring the admin PC and starting the OpenScape Business Assistant (WBM) administration program for the first time.

The initial startup of the communication system must be performed prior to integrating the communication system into the internal LAN. Problems can occur if the pre-configured IP address of the communication system already exists in the internal LAN and/or if a DHCP server is already in use. In such cases, the IP address of the communication system must first be reconfigured and/or the DHCP server of the communication system must be deactivated. Only then can the communication system be integrated into the internal LAN.



Prior to initial startup, please follow the instructions on data protection and data security.



The OpenScape Business X1R must only be switched on when the housing is closed.

Connecting the admin PC

To configure the communication system, the admin PC is directly connected to the "LAN" interface of the communication system. The communication system is then configured to obtain its IP address from the internal DHCP server of the communication system. After successful installation, the admin PC can be integrated into the internal LAN without any further configuration changes.

6.5.1 How to Restart the Communication System

Prerequisites

The hardware was correctly installed.

The memory card (with the system software) was inserted.

The communication system has not been integrated into the customer LAN yet.

Step by Step

Connect the communication system to the power supply.



Risk of electric shock through contact with live wires!

Make sure that the communication system is grounded by a separate ground wire.

The communication system is now started up, during this process, the system LEDs light up in different colors and sequences. During startup, the communication system must not be disconnected from the power supply.

After completion of the startup, the "Run" LED on the mainboard flashes green at 1Hz (0.5 sec on / 0.5 sec off).

6.5.2 How to Connect the Admin PC to the Communication System

Prerequisites

The communication system is ready for use.

Step by Step

1) Start the admin PC.

- 2) Check whether a dynamic IP address can be assigned to the PC. If not, you will have to reconfigure the admin PC. To do this you must have Administrator rights.



The IP settings described here apply to Windows 7. For more detailed information on the configuration for other Windows operating systems, please refer to the appropriate operating system instructions.

- a) Select **Start > Control Panel**, double-click on **Network and Internet** and then click **Network and Sharing Center**.
 - b) Click on **LAN connection** for the appropriate active network and then click **Properties**.
 - c) On the **Networking** tab, use the left mouse button to select the **Internet Protocol Version 4(TCP/IPv4)** entry and then click on **Properties**.
 - d) Click on the **General** and ensure that the radio button **Obtain an IP address automatically** is enabled. If it is not, then activate it.
 - e) Close all open windows with **OK**.
- 3) Connect the just configured LAN port of the admin PC to the LAN port "LAN" of the communication system using a LAN cable. The admin PC is assigned a dynamic IP address via this interface.

6.5.3 How to Start the WBM

Prerequisites

The communication system is ready for use. The "Run" LED on the mainboard flashes green at 1Hz (0.5 sec on / 0.5 sec off).

The admin PC and the communication system can communicate with one another over the LAN.

Step by Step

- 1) Start the web browser on the admin PC and open the login page of the OpenScape Business Assistant (WBM) at the following address:

`https://192.168.1.2`



If the WBM cannot be started, check the LAN connection and repeat the call. If it still cannot be started, check whether the IP address has been blocked by your PC's internal firewall. More detailed information can be found in the documentation of your firewall.

- 2) If the browser reports a problem with a security certificate, install the certificate (using the example of Internet Explorer V10).
 - a) Close the web browser.
 - b) Open the web browser with administrator rights by clicking the right mouse button on the web browser icon and selecting the menu item **Run as administrator** from the context menu.
 - c) Allow the User Account Control.
 - d) Open the login page of the OpenScape Business Assistant (WBM) at the following address:

`https://192.168.1.2`

- e) Click on **Continue to this website**.
- f) Click on the message **Certificate Error** in the navigation bar of the web browser.
- g) Click on **View Certificates**.
- h) Click on **Install Certificate** (only visible with administrator rights).
- i) Select the option **Local Computer** and confirm with **Next**.
- j) Select the option **Place all certificates in the following store**, click **Browse** and specify **Trusted Root Certification Authorities**.
- k) Confirm with **OK** and then with **Next** and **Finish**.
- l) Confirm the certificate import with **OK** and close the certificate window **OK**.
- m) Close the web browser.
- n) Start the web browser again (without administrator rights) and open the login page of the OpenScape Business Assistant (WBM) at the following address:

`https://192.168.1.2`

- 3) Click on the language code at the top right and select the language in which the user interface of the WBM is to be displayed from the menu. The Login page will be displayed in the selected language.
- 4) In the field under **Login**, enter the default user name `administrator@system` for access as an administrator.



If you go to the **Password** field after entering `administrator@system` will be added automatically.

- 5) In the second field under **Login**, enter the default password `administrator` for access as an administrator.
- 6) Click **Login**.
- 7) The following steps are only required once when first logging on to the WBM:
 - a) Reenter the default password **administrator** in the **Password** field.
 - b) Enter a new password in the **New Password** and **Confirm New Password** fields to protect the system against misuse. Note case

usage and the status of the Num und CapsLock keys. The password is displayed as a string of asterisks (*).



The password must be at least 8 characters long and include a digit. Make sure that you remember your new password.

- c) Click **Login**.
- d) Select the current date and enter the correct time.
- e) Click **OK & Next**. You are automatically logged out of the WBM.
- f) In the field under **Login**, enter the default user name `administrator@system` for access as an administrator.



If you go to the **Password** field after entering `administrator@system` will be added automatically.

- g) In the second field under **Login**, enter your new password for access as an administrator.
- h) Click **Login**. The home page of the WBM appears.

Next steps

Start the initial installation.

6.6 Integration into the Customer LAN

The WBM wizard **Initial Installation** is used for integration into the customer LAN. This wizard guides you through the basic settings for integrating the communication system into the existing LAN.

6.6.1 How to Start the Initial Installation Wizard

Prerequisites

The WBM has been started.

Step by Step

- 1) In the navigation bar, click on **Setup**.
- 2) Click on **Edit** to start the **Initial Installation** wizard.



If the size of the browser window cannot display the workspace in its entirety at low screen resolutions, a horizontal or vertical scroll bar appears at the sides and can be used to scroll to the required section.

Next steps

Perform initial installation as described in the following step-by-step instructions. Fields that are not described here are preset for the default scenario and should only be changed if they are not appropriate for your network data. For

detailed information, refer to the descriptions provided in the Administrator documentation for the individual wizards.

6.6.2 System Settings

The **System Settings** window is used to configure the system settings of the communication system.

Proceed as follows:

1) Set the display logo and the product name

Specify a display text to be displayed on the display of the system phones. Additionally, you can also select the product name.

2) Edit IP addresses (if required)

By default, the communication system is assigned an IP address and a subnet mask. You may need to adjust the IP address and/or subnet mask to your own IP address range.

In addition, you can specify the IP address of your default router, e.g., the IP address of the Internet router.

If the netmask is to be expanded, e.g., from 255.255.**255**.0 to 255.255.**0**.0, both the internal IP address of the communication system and the IP address of the Admin port must be changed because they are not allowed to be in the same network segment as the IP address of the communication system (see also [IP Address Scheme](#) on page 58).

6.6.2.1 How to Set the Display Logo and the Product Name

Prerequisites

You are in the **System Settings** window.

Section	Field	Value
OpenScape Business	Display Logo	OSBiz
	Brand	OpenScape Business
	OpenScape Business - IP address	192.168.186.13
	OpenScape Business - Netmask	255.255.255.0
Application Board	OpenScape Business - Default Routing via	LAN
	OpenScape Business - IP Address of Default Router	192.168.186.22
	Application Board - IP address	192.168.1.3
Application Board	Application Board - Netmask	255.255.255.0
	Application Board - IP Address of Default Router	192.168.186.22

Step by Step

- 1) In the **Display Logo** field, enter a text of your choice (e.g., OpenScape Biz). The text can contain up to 16 characters. Avoid the use of diacritical characters such as umlauts and special characters.

- 2) Select the desired time product name in the **Brand** drop-down list.

Next steps

Edit IP addresses (if required) or configure DHCP.

6.6.2.2 How to Specify the IP Addresses (Optional)

Prerequisites

You know the IP address range of your internal network.

You are in the **System Settings** window.

Setup - Wizards - Basic Installation - Initial Installation

System Settings

Display Logo:

Brand:

OpenScape Business

OpenScape Business - IP address:

OpenScape Business - Netmask:

OpenScape Business - Default Routing via:

OpenScape Business - IP Address of Default Router:

Application Board

Application Board - IP address:

Application Board - Netmask:

Application Board - IP Address of Default Router:

Step by Step

- 1) Specify the IP address of the communication system:
 - a) In the field **OpenScape Business - IP address**, enter an IP address that lies within the IP address range of your internal network (e.g., internal network: 192.168.1.x, OpenScape Business: 192.168.1.2).



The IP address for OpenScape Business must not be assigned to any other existing network client, since this would result in an IP address conflict.

- b) Enter the subnet mask of your internal network (e.g., 255.255.255.0) in the **OpenScape Business - Subnet Mask** field.
- 2) Specify the IP address of the default router:
 - a) In the **OpenScape Business - Default Routing via** field, select the entry **LAN**.
 - b) Enter the IP address of your default router in the **OpenScape Business - IP Address of Default Router** field (e.g., internal network: 192.168.1.x, Internet router as default router: 192.168.1.1).
- 3) Click on **OK & Next**.

Next steps

Configure DHCP.

6.6.2.3 How to Specify the Device Name

Prerequisites

You are in the **System Settings** window.

System is in DTAG mode.

The screenshot shows the 'System Settings' window with the following configuration:

- System Settings**
 - Display Logo: OSBiz
 - Brand: OpenScape Business
- OpenScape Business**
 - OpenScape Business - IP address: 192.168.186.13
 - OpenScape Business - Netmask: 255.255.255.0
 - OpenScape Business - Default Routing via: LAN
 - OpenScape Business - IP Address of Default Router: 192.168.186.22
- Application Board**
 - Application Board - IP address: 192.168.1.3
 - Application Board - Netmask: 255.255.255.0
 - Application Board - IP Address of Default Router: 192.168.186.22

Step by Step

1) Check the **Automatic RSP.servicelink registration** checkbox:

Device Name field is editable.

2) Specify the **Device Name**.

By selecting the Automatic RSP.servicelink registration, system will try automatically every 10 minutes to register and connect to RSP servers using the provided Device Name.

3) Click on **OK & Next**.

Next steps

Configure DHCP.

6.6.3 DHCP Settings

In the window **DHCP global settings** enable and configure or disable the internal DHCP server of the communication system.

A DHCP server automatically assigns a unique IP address to each IP station (IP system phones, PCs, etc.) and provides the IP stations with network-specific data such as the IP address of the default gateway (Internet router), for example.

The DHCP server can be an external DHCP server (e.g., the DHCP server of the Internet router) or the internal DHCP Server of the Linux server integrated into the communication system.

Either the integrated DLI of the communication system or an external DLS server can be used for automatically updating the software of the IP system phones (*Administrator Documentation, Deployment Service (DLS and DLI)*).

The IP address of the integrated DLI or the external DLS server must be known to the DHCP server.

You have the following options:

- Enable and configure the internal DHCP server

If the internal DHCP server of the communication system is used, an external DHCP server (e.g., the DHCP server of the Internet router) must be deactivated. The settings of the internal DHCP server may have to be adapted to the customer LAN. If the internal DHCP server and the internal DLI are used, the system phones are updated automatically. If an external DLS server is used, its IP address must be entered in the internal DHCP server using Expert mode (*Administrator Documentation, Deployment Service (DLS and DLI)*).

- Disable the internal DHCP server

If an external DHCP server is used, the internal DHCP server of the communication system must be disabled. For IP system phones to be automatically supplied with the latest phone software, network-specific data (such as the IP address of the internal DLI or the external DLS server) must be specified on the external DHCP server.



Not all external DHCP servers support the entry of network-specific data! In this case, the data must be entered manually on all IP system phones.

6.6.3.1 How to Disable the Internal DHCP Server

Prerequisites

An external DHCP server (e.g., the DHCP server of the Internet router) is enabled in the internal network.

You are in the **DHCP Global Settings** window.

Step by Step

- 1) Clear the **Enable DHCP Server** check box.
- 2) Click on **OK & Next**.

Next steps

Configure country and time settings.

6.6.3.2 How to Enable and Configure the Internal DHCP Server

Prerequisites

The external DHCP server (e.g., the DHCP server of the Internet router) has been disabled in the internal network.

You are in the **DHCP Global Settings** window.

Initial Setup for OpenScape Business X1R

Setup - Wizards - Network / Internet - Network Configuration

DHCP Global Settings

In Expert Mode, DHCP was set to Relay Agent. If you now switch the DHCP server on, the IP addresses HiPath OpenOffice will be distributed. Network problems may occur as a result.

Enable DHCP Server:

Netmask:

Broadcast Address: (optional)

Default Gateway

Preferred Gateway:

DNS Server

Domain Name:

Preferred Server:

Lease time in hours (0 infinite):

Enable Dynamic DNS Update:

Step by Step

- 1) Leave the **Enable DHCP Server** check box enabled.
- 2) Go to the **Netmask** field and adjust the subnet mask to your IP address range (for example, 255 . 255 . 255 . 0).
- 3) In the field **Preferred Gateway**, enter the IP address of the Internet router (e.g., 192 . 168 . 1 . 1).
- 4) In the field **Preferred Server**, enter the IP address of the DNS server (e.g., the IP address of the Internet router, 192 . 168 . 1 . 1).
- 5) Click on **OK & Next**. The **DHCP Address Pool** window appears.

Setup - Wizards - Network / Internet - Network Configuration

DHCP Address Pool

Subnet address

Subnet mask

Address range

Address range 1 -

- 6) Specify the values for **Subnet address**, **Netmask** and **Address range 1** in order to define the IP address range to be managed by the internal DHCP server.

If the internal network uses static IP addresses (e.g., for a printer server), the IP address range (DHCP address pool) must be selected so that the fixed IP addresses are not included within this range.

Example:

Internet router: 192 . 168 . 1 . 1

OpenScape Business: 192 . 168 . 1 . 2

Subnet address: 192 . 168 . 1 . 0

Subnet mask: 255 . 255 . 255 . 0

Printer Server: 192 . 168 . 1 . 10

DHCP address pool: 192 . 168 . 1 . 50 to 192 . 168 . 1 . 254

- 7) Click on **OK & Next**.

Next steps

Configure country and time settings.

6.6.4 Country and Time Settings

In the **Basic Configuration** window, select your country and the language for the event logs and set the date and time. If you are using the integrated Cordless solution, enter the system-wide DECT system ID here.

Proceed as follows:

1) Select the country code and the language to be used for event logs

For country initialization to work correctly, you must select the country in which the communication system is operated. In addition, you can select the language in which the event logs (system event logs, errors logs, etc.) are to be stored.

2) Enter the DECT system identification (only for integrated Cordless solution)

If you are using the integrated Cordless solution, enter the system-wide DECT system ID here.

3) Setting Date and Time

- **How to Set the Date and Time Manually**

The communication system and the stations (IP phones, TDM phones, client PCs) should have a uniform time base (date and time). If no SNTP server has been specified for time synchronization, the date and time can also be entered manually.

- **How to Obtain the Date and Time from an SNTP Server**

The communication system and IP stations (IP phones, client PCs) should have a uniform time base (date and time). This time base can be provided by an SNTP server. The SNTP server can be located on the internal network or the Internet.

The IP phones receive the date and time automatically from the communication system. The client PCs on which the UC clients run must be set so that they are synchronized with the communication system (see the operating system instructions for the client PCs).

6.6.4.1 How to Select the Country Code and the Language for Event Logs

Prerequisites

You are in the **Basic Configuration** window.

Setup - Wizards - Basic Installation - Initial Installation

Basic Configuration

Language settings

System Country Code:

Language for Customer Trace Log:

Time settings

Date and Time: Day: Month: Year: hh:mm:ss:

Timezone:

Detect date and time via an SNTP server

Date and Time via an external SNTP Server:

IP Address / DNS Name of External Time Server:

Poll Interval for External Time Server:

C.MI data

System ID:

Initial Setup for OpenScape Business X1R

Step by Step

- 1) In the **System Country Code** drop-down list, select the country where the communication system is operated.
- 2) In the **Language for Customer Event Log** field, enter the language in which the event logs (system event logs, error logs, etc.) are to be output.

Next steps

Enter the DECT system identification (only for integrated Cordless solution)

or

Set the date and time manually or obtain the date and time from an SNTP server.

6.6.4.2 How to Enter the DECT System ID

Prerequisites

You are in the **Basic Configuration** window.

Setup - Wizards - Basic Installation - Initial Installation

Basic Configuration

Language settings

System Country Code: Germany

Language for Customer Trace Log: English

Time settings

Date and Time: Day 03 Month 03 Year 2023 hh:mm:ss 10:40:00

Timezone: (UTC +02:00) Athens, Beirut, Istanbul, Minsk

Detect date and time via an SNTP server

Date and Time via an external SNTP Server:

IP Address / DNS Name of External Time Server: 192.168.142.49

Poll Interval for External Time Server: Continuous

CMI data

System ID: 00000000

Step by Step

In the **CMI data** area under **System ID**, enter the 8-digit hexadecimal DECT system ID that you received on purchasing your integrated Cordless solution.

Next steps

Set the date and time manually or obtain the date and time from an SNTP server.

6.6.4.3 How to Set the Date and Time Manually

Prerequisites

You are in the **Basic Configuration** window.

Setup - Wizards - Basic Installation - Initial Installation

Basic Configuration

Language settings

System Country Code:

Language for Customer Trace Log:

Time settings

Date and Time: Day Month Year hh:mm:ss

Timezone:

Detect date and time via an SNTP server

Date and Time via an external SNTP Server:

IP Address / DNS Name of External Time Server:

Poll Interval for External Time Server:

CMI data

System ID:

Step by Step

- 1) Enter the current values for **Date and Time**.
- 2) Select the desired time zone in the **Timezone** field.
- 3) Click on **OK & Next**.



In case the Timezone setting is changed, then at the last step of Initial Wizard the system will be restarted.

If Timezone setting remain untouched then system will not be restarted.

Next steps

Specify UC solution.

6.6.4.4 How to Obtain the Date and Time from an SNTP Server

Prerequisites

You are in the **Basic Configuration** window.

Setup - Wizards - Basic Installation - Initial Installation

Basic Configuration

Language settings

System Country Code:

Language for Customer Trace Log:

Time settings

Date and Time: Day Month Year hh:mm:ss

Timezone:

Detect date and time via an SNTP server

Date and Time via an external SNTP Server:

IP Address / DNS Name of External Time Server:

Poll Interval for External Time Server:

CMI data

System ID:

Step by Step

- 1) Select the **Date and Time via an external SNTP Server** check box.

Initial Setup for OpenScape Business X1R

- 2) Enter the IP address or the DNS name of the SNTP server (e.g., `0.de.pool.ntp.org`) in the **IP Address / DNS Name of External Time Server** field).
- 3) From the drop-down list **Poll Interval for External Time Server**, select after how many hours the Date and Time should be synchronized by the SNTP Server (recommended value: 4 h).
- 4) Click on **OK & Next**.

Next steps

Specify UC solution.

6.6.5 UC Solution

In the **Change application selection** window, select the UC solution to be used.

You have the following options:

- **Package with UC Smart**
The UC solution UC Smart is integrated on the OpenScape Business X1R mainboard.
- **Package with UC Suite on OSBiz UC Booster Server**
The UC solution UC Smart is integrated on the external Linux server "OpenScape Business UC Booster Server".
- **Package with UC Suite on OSBiz UC Booster Server**
The UC solution UC Suite is integrated on the external Linux server "OpenScape Business UC Booster Server".

6.6.5.1 How to Define the UC Solution

Prerequisites

You have purchased licenses for either of the UC solutions, UC Smart or UC Suite.

You are in the **Change application selection** window.

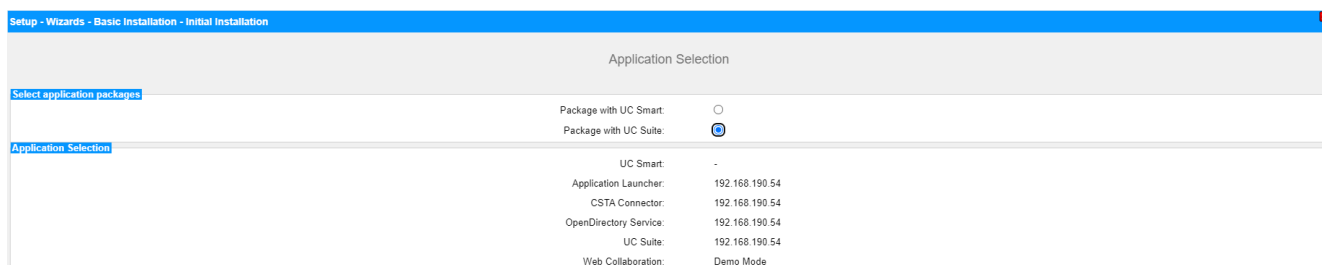

Step by Step

- 1) If you are using the UC solution UC Smart without a UC Booster Server, click **Package with UC Smart**.

- 2) If you are using the UC solution UC Smart with the UC Booster Server, click on **Package with UC Smart on OSBiz UC Booster Server**. In addition, enter the IP address of the external Linux server "OpenScape Business UC Booster Server" in the **IP address of OSBiz UC Booster Server** field.
- 3) If you are using the UC solution UC Suite with the UC Booster Server, click on **Package with UC Suite on OSBiz UC Booster Server**. In addition, enter the IP address of the external Linux server "OpenScape Business UC Booster Server" in the **IP address of OSBiz UC Booster Server** field.
- 4) Click on **OK & Next**.
- 5) The **Initial installation** wizard is closed. Click **Finish**.
- 6) Exit the WBM by right-clicking the **Logout** link on the top right of the screen and then close the window.



If IP addresses or DHCP server settings have been changed, the communication system performs a restart. This can take a few minutes.

Next steps

Connect the communication system to the customer LAN.

6.6.6 Connecting the Communication System to the Customer LAN

After a successful initial installation, the communication system is connected to the existing customer LAN.

6.6.6.1 How to Connect the Communication System to the Customer LAN

Prerequisites

The communication system is ready for use.

Step by Step

- 1) Remove the LAN cable of the admin PC from the central LAN port "LAN" and integrate the admin PC in the customer's LAN by connecting it to a switch, for example.
- 2) Connect a LAN cable to the middle "LAN" port of the communication system.
- 3) Integrate the communication system via this LAN cable in the customer LAN by connecting it to a switch, for example.

Next steps

Start the basic configuration.

6.7 Basic Configuration

The **Basic Installation** wizard is used for basic configuration. Basic configuration includes the most important settings for operating the communication system.

The Basic Installation Wizard includes a progress indicator showing the current step, as well as the steps that follow.

6.7.1 How to Start the Basic Installation Wizard

Prerequisites

The **Initial installation** has been completed.

The communication system is integrated in the customer LAN

The communication system is ready for use. The "Run" LED on the mainboard flashes green at 1Hz (0.5 sec on / 0.5 sec off).

Step by Step

- 1) Open the WBM login page on the admin PC by entering the following address in your web browser:

`https://<IP address of OpenScape Business>`

The default IP address for OpenScape Business is 192.168.1.2, i.e., `https://192.168.1.2`, for example.

- 2) In the **User Name** field, enter the default user name `administrator@system` for access as an administrator.
- 3) Enter the password you defined at initial startup in the **Password** field.
- 4) Click on **Login**.
- 5) In the navigation bar, click on **Setup**.
- 6) Click on **Edit** to start the **Basic Installation** wizard.

Next steps

Perform basic installation as described in the following step-by-step instructions. Fields that are not described here are preset for the default scenario and should only be changed if they are not appropriate for your network data. For detailed information, refer to the descriptions provided in the Administrator documentation for the individual wizards.

6.7.2 System Phone Numbers and Networking

Enter the system phone numbers (PABX number, country and area code, international prefix) in the **Overview** window and specify whether OpenScape Business is to be networked with other OpenScape Business systems.

Proceed as follows:

1) Enter system phone numbers

- Enter system phone numbers for point-to-point connection

Here you enter the system phone number for your point-to-point connection and the country code and area code.

The entry of the country code is mandatory for Internet telephony and conference server functionality.

The international prefix is preset, depending on the previously dialed country code.

- Enter system phone numbers for point-to-multipoint connection

Here you enter the country code and area code for your point-to-multipoint connection.

The entry of the country code is mandatory for Internet telephony and Meet-Me conferences.

The international prefix is preset, depending on the previously dialed country code.

2) Activate or deactivate networking

If OpenScape Business is to be networked with other OpenScape Business systems, networking must be enabled, and OpenScape Business must be assigned a node ID. Every OpenScape Business must have a unique node ID in the network.

6.7.2.1 How to Enter the System Phone Numbers for a Point-to-Point connection

Prerequisites

You have a point-to-point connection.

You are in the **System Overview** window.

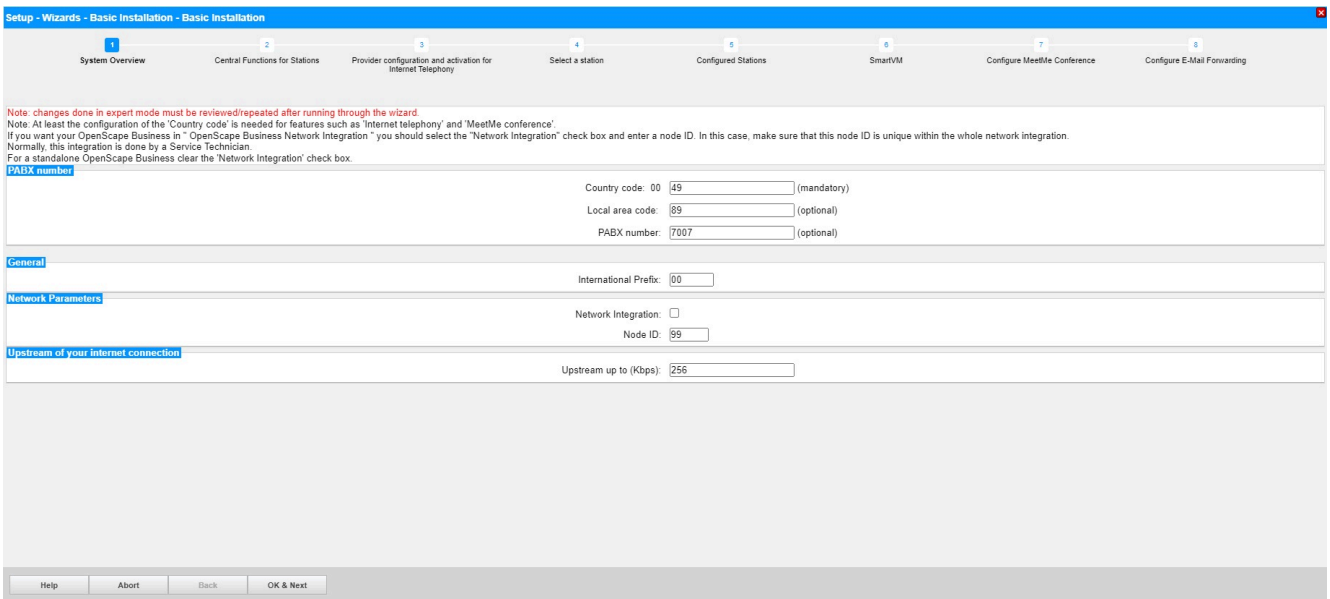

Step by Step

- 1) In the **Country Code** field, enter the country code prefix, e.g., 49 for Germany or 1 for the U.S.
- 2) Enter the local area code, e.g., 89 for Munich, in the **Local area code** field.
- 3) Enter the system phone number of your trunk connection, e.g., 7007 (your connection number), in the **PABX number** field.
- 4) Change the **International Prefix** field only if required. The applicable values for Germany and the United States are 00 and 011, respectively.

For international calls, the phone number is preceded by the international prefix and the country code, e.g., "00-1-..." for calls from Germany to the USA and "011-49-..." for calls from the USA to Germany.

Next steps

Activate or deactivate networking

6.7.2.2 How to Enter the System Phone Numbers for a Point-to-Multipoint Connection

Prerequisites

You have a point-to-multipoint connection.

You are in the **System Overview** window.

The screenshot shows the 'Setup - Wizards - Basic Installation - Basic Installation' window. The progress bar indicates Step 1: System Overview is active. Below the progress bar, there are several sections with configuration fields:

- PABX number**: Country code: 00 (mandatory); Local area code: (optional); PABX number: (optional).
- General**: International Prefix:
- Network Parameters**: Network Integration: ; Node ID:
- Upstream of your internet connection**: Upstream up to (Kbps):

At the bottom, there are buttons for Help, Abort, Back, and OK & Next.

Step by Step

- 1) In the **Country Code** field, enter the country code prefix, e.g., 49 for Germany or 1 for the U.S.
- 2) Enter the local area code, e.g., 89 for Munich, in the **Local area code** field.
- 3) Leave the **PABX number** field empty.

- 4) Change the **International Prefix** field only if required. The applicable values for Germany and the United States are 00 and 011, respectively.

For international calls, the phone number is preceded by the international prefix and the country code, e.g., "00-1-..." for calls from Germany to the USA and "011-49-..." for calls from the USA to Germany.

Next steps

Activate or deactivate networking

6.7.2.3 How to Activate or Deactivate Networking

Prerequisites

You are in the **System Overview** window.

Setup - Wizards - Basic Installation - Basic Installation

1 System Overview 2 Central Functions for Stations 3 Provider configuration and activation for Internet Telephony 4 Select a station 5 Configured Stations 6 SmartVM 7 Configure MeetMe Conference 8 Configure E-Mail Forwarding

Note: changes done in expert mode must be reviewed/repeated after running through the wizard.
 Note: At least the configuration of the 'Country code' is needed for features such as 'Internet telephony' and 'MeetMe conference'.
 If you want your OpenScape Business in "OpenScape Business Network Integration" you should select the "Network Integration" check box and enter a node ID. In this case, make sure that this node ID is unique within the whole network integration.
 Normally, this integration is done by a Service Technician.
 For a standalone OpenScape Business clear the 'Network Integration' check box.

PABX number

Country code: 00 (mandatory)
 Local area code: (optional)
 PABX number: (optional)

General

International Prefix:

Network Parameters

Network Integration:
 Node ID:

Upstream of your internet connection

Upstream up to (Kbps):

Help Abort Back OK & Next

Step by Step

- 1) If the communication system is to be networked with other communication systems:
 - a) Select the **Network Integration** check box.
 - b) In the **Node ID** field for the communication system, enter a node ID that is unique in the internetwork (digits from 1 through 100 are possible).
- 2) If the communication system is not to be networked with other communication systems, leave the **Network Integration** check box disabled.

Next steps

Configure the upstream of your Internet connection.

6.7.3 Station Data

If necessary, you can configure your own individual dial plan instead of the predefined default dial plan in the **Central Functions for Stations** window and import additional station data. In an internetwork, the default dial plan must be adapted to the dial plan of the internetwork.

The default dial plan contains predefined numbers for different types of stations (IP phones, analog phones, ...) and for special functions (Internet telephony, voicemail box, AutoAttendant, ...).

The station data includes the internal call numbers, DID numbers and names of the stations. This data and other station data can be imported into the communication system during the basic configuration via an XML file in UTF-8 format.



An XML template with the appropriate explanations can be found in the WBM under **Service Center > Documents > CSV Templates**. You can enter your data in this template by using Microsoft Excel, for example.

You have the following options:

- **Configure station data without an internetwork**

Proceed as follows:

- 1) Display the station data

You can have all preconfigured station numbers and station data displayed.

- 2) Delete all station numbers (optional)

If you use an individual dial plan, you must delete all preconfigured station numbers.

- 3) Adapt preconfigured station numbers for the individual dial plan (optional)

If you are using an individual dial plan, you can adapt the preconfigured phone numbers to your own dial plan.



If the user passes through the **Change preconfigured functional call numbers**, any existing custom configuration done in UC Suite must be reviewed or repeated (e.g., pilot queues).

- 4) Import station data from an XML file (optional)

You can easily import your individual station numbers, including any additional station data, during the basic configuration via an XML file.

- **Configure station data with an internetwork**

Proceed as follows:

- 1) Delete all station numbers

If the UC Suite is used in an internetwork, a closed numbering plan is required, i.e., all station numbers in the internetwork must be unique. For

this reason, any preconfigured station numbers must be deleted and only stations numbers adapted for the internetwork must be used.

2) Import station data from an XML file

The station numbers adapted for the internetwork and any additional station data can be easily imported during the basic configuration via an XML file. This file can contain all stations in the internetwork. During import, only the station numbers and the station data assigned to the previously specified node ID of the communication system will be transferred.

6.7.3.1 How to Display the Station Data

Prerequisites

You are in the **Central Functions for Stations** window.

Step by Step

- 1) Select the **Display stations configuration** radio button.
- 2) Click on **Execute function**. A list of stations with the preconfigured phone numbers (default dial plan) is displayed.
- 3) Click on **OK**. You are taken back to the **Central Functions for Stations** window.
- 4) If you do not want to change any station data, click **OK & Next**.

6.7.3.2 How to Delete all Call Numbers

Prerequisites

You are in the **Central Functions for Stations** window.

Step by Step

- 1) Enable the radio button **Delete all station call numbers**.
- 2) Enable the check box **Delete All Call Addresses**.

Initial Setup for OpenScape Business X1R

- 3) Click on **Execute function** to delete all the preset call numbers. The **Change preconfigured call and functional numbers** window appears.

Setup - Wizards - Basic Installation - Basic Installation

Change preconfigured call and functional numbers

- The Internet Telephony numbers must be available, it is not possible to delete these numbers.
- Please keep in mind, that these numbers are not available for station or group dialing use.
- Automatic changes may be applied. Please check LCR dial plan and correct if necessary.

Preconfiguration for Internet Telephony	<input type="text"/>	<input type="text"/>	<input type="text"/>
Announcement Player	<input type="text" value="659999"/>	<input type="text"/>	<input type="text"/>
Voicemail call number (Smart VM)	<input type="text"/>	<input type="text"/>	<input type="text"/>
Autoattendant call number (Smart VM)	<input type="text"/>	<input type="text"/>	<input type="text"/>
Attendant code	<input type="text"/>	<input type="text"/>	<input type="text"/>
Remote Admin call number	<input type="text" value="659995"/>	<input type="text"/>	<input type="text"/>
Licensing call number	<input type="text" value="659994"/>	<input type="text"/>	<input type="text"/>
Functional numbers for Conferencing	<input type="text" value="-"/>	<input type="text" value="-"/>	<input type="text" value="-"/>
Functional number for MeetMe Conferencing	<input type="text" value="-"/>	<input type="text"/>	<input type="text"/>

- 4) In the new window, adjust the codes and special call numbers to suit your preferences.
- 5) Click **OK** to go back to the **Central Functions for Stations** window.
- 6) If you do not want to change any further station data, click **OK & Next**.

6.7.3.3 How to Adapt Preconfigured Station Numbers for the Individual Dial Plan

Prerequisites

You are in the **Central Functions for Stations** window.

Step by Step

- 1) Enable the radio button **Change preconfigured call and functional numbers**.
- 2) Click on **Execute function**. The **Change preconfigured call and functional numbers** window appears.

Setup - Wizards - Basic Installation - Basic Installation

Change preconfigured call and functional numbers

- The Internet Telephony numbers must be available, it is not possible to delete these numbers.
- Please keep in mind, that these numbers are not available for station or group dialing use.
- Automatic changes may be applied. Please check LCR dial plan and correct if necessary.

Preconfiguration for Internet Telephony	<input type="text"/>	<input type="text"/>	<input type="text"/>
Announcement Player	<input type="text" value="659999"/>	<input type="text"/>	<input type="text"/>
Voicemail call number (Smart VM)	<input type="text"/>	<input type="text"/>	<input type="text"/>
Autoattendant call number (Smart VM)	<input type="text"/>	<input type="text"/>	<input type="text"/>
Attendant code	<input type="text"/>	<input type="text"/>	<input type="text"/>
Remote Admin call number	<input type="text" value="659995"/>	<input type="text"/>	<input type="text"/>
Licensing call number	<input type="text" value="659994"/>	<input type="text"/>	<input type="text"/>
Functional numbers for Conferencing	<input type="text" value="-"/>	<input type="text" value="-"/>	<input type="text" value="-"/>
Functional number for MeetMe Conferencing	<input type="text" value="-"/>	<input type="text"/>	<input type="text"/>

- 3) Adjust the preconfigured call numbers to suit your preferences.
- 4) Click **OK** to go back to the **Central Functions for Stations** window.
- 5) If you do not want to change any further station data, click **OK & Next**.

6.7.3.4 How to Import the Station Data from an XML File

Prerequisites

You are in the **Central Functions for Stations** window.

An XML file with the entered data is available in UTF-8 format. An XML template can be found under **Service Center > Documents > CSV Templates**.

Step by Step

- 1) Enable the radio button **Import XML file with station data**.
- 2) Click **Execute function**.
- 3) Use **Browse** to select the created XML file and click **Open**.
- 4) Click **OK** when finished. The station data is imported.
- 5) Click **OK & Next**.

6.7.3.5 How to display Mass data

Prerequisites

You are in the **Central Functions for Stations** window.

Step by Step

- 1) Enable the **Mass Data wizard** button.
- 2) Click on **Execute function**.
- 3) In the **Mass Data Wizard** window you can validate the entries of the system, by clicking on **Validate**. There are two types of validation, the Front End Consistency Check and the Back End Consistency Check.
The green color in validation field indicates only the actions that have been recently validated. The validation of data is not saved, so if the values are changed the user has to validate again the data.
- 4) During Back End Consistency Check and after the successful validation of data no editing in **Mass Data Wizard** window is possible. After the successful validation **OK&Next** becomes available with Edit restrict mode. If the user clicks on **Back**, Edit mode becomes available but **OK&Next** disappears. When the validation is unsuccessful Edit mode remains intact and **OK&Next** stays hidden.



The user can click on **Back** to re-edit the data and the window returns to Edit mode again. The Edit restrict mode ensures that the user cannot click on **OK&Next** and submit changes that are not validated.

5) When **Mass Data Wizard** is configured successfully click on **Finish**. In the finish page is displayed a sum up with all the changes.

Fields that are not editable are already filled in with the relevant values obtained by the Database. As a result Copy/paste function will have no effect in data.

Type field is a selectable drop down menu with editing functionality. However the only options accepted are No Port, System Client, SIP Client, Deskshare User and potentially a predefined value based on the assembly group it belongs. If the user tries to enter something else then this will not be accepted and drop down menu will not be disappear persisting in providing a proper entry.

Another restriction is that some ports are not changeable (for instance ports belonging in an Analog card, type is not changeable and should remain Analog Station). All restrictions apply when the user tries to perform copy paste on top of Type column. If the user tries to paste irrelevant data not compromising with the rules above paste will not be performed at all.

Copy and paste can be applied on the whole table as well as on specific parts.



When selecting two following cells, with a numeric value, and you pull down the fields the following columns are not filled in with ascending numbers but they are filled in with a copy of the selected cells.

6.7.4 Internet Access

The **Configure Internet Access** window can be used to configure Internet access.

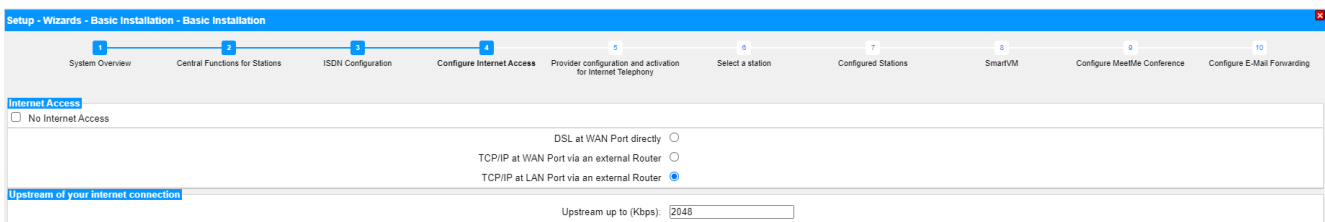

The configuration of Internet access in the WBM depends on whether the Internet connection has already been set up in an external router or whether it occurs via an Internet modem and thus needs to be set up in the WBM.

Only one of the options listed here may be selected.

- Internet access through an Internet modem (**DSL at WAN port directly**)

You want to operate the communication system directly at an Internet modem (DSL, cable, UMTS ...). OpenScape Business has the Internet router integrated. Enter the access data of the Internet Service Provider

(ISP) directly in the communication system and use the WAN port of the communication system.



You have the following options:

- **Internet access via a preconfigured ISP**
- **Internet access via the standard ISP PPPoE**
- **Internet access via the standard ISP PPTP**

If your ISP is not listed under the preconfigured ISPs, use the default ISP PPPoE or PPTP.

- Internet access via an external Internet router

You want to operate the communication system at an external Internet router. The Internet Service Provider is already configured in the Internet router.

You have the following options:

- **Internet access via an external Internet router at the WAN port (TCP/IP at WAN port via an external router)**

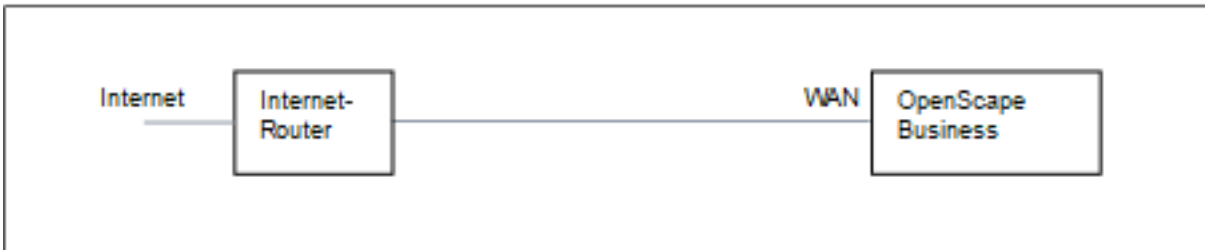

To do this, you use the WAN port of the communication system. OpenScape Business either knows the Internet router or works as a DHCP client. This option can be used if the Internet router is located in another network segment and has its own DHCP server.

- **Internet access via an external Internet router at the LAN port (TCP/IP at LAN port via an external router)**

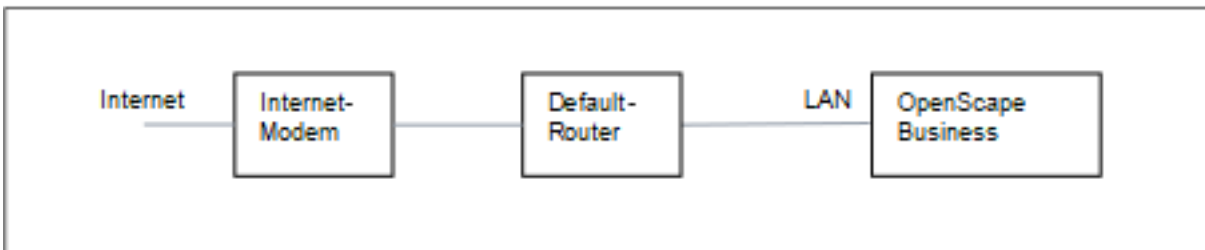

To do this, you use the LAN port of the communication system. OpenScape Business knows only the default router and not the underlying infrastructure. To activate the connection to the Internet router,

the IP address of the default router and that of the DNS server must be made known to the communication system.

- Deactivate Internet access (default setting)

You do not want to use the Internet.

6.7.4.1 How to Configure Internet Access via an External Internet Router over the LAN Port

Prerequisites

The communication system must be connected to the customer LAN via the "LAN" interface. The connection must not use the WAN port, since the WAN port will be disabled.

You are in the **Configure Internet Access** window.

Step by Step

- 1) Disable the **No Internet Access** check box.
- 2) Activate the radio button **TCP/IP at LAN Port via an external router**, enter the upload speed of your Internet connection in the **Upstream up to (Kbps)** field and click **OK & Next**.

Setup - Wizards - Basic Installation - Basic Installation

1 System Overview 2 Central Functions for Stations 3 ISDN Configuration 4 Routing Configuration 5 Provider configuration and activation for Internet Telephony 6 Select a station 7 Configured Stations 8 SmartVM 9 Configure MeetMe Conference 10 Configure E-Mail Forwarding

DNS Server

IP Address of primary DNS Server: 192.168.186.22

Default Router

IP Address of Default Router: 192.168.186.22

Application Board - IP Address of Default Router: 192.168.186.22

- 3) Enter the IP address of the local DNS server (e.g., the Internet router) or the Internet DNS server (for Internet telephony, for example) in the **IP address of the preferred DNS server** field.
- 4) Enter the IP address of the external Internet router in the **IP Address of Default Router** field.
- 5) Click on **OK & Next**.

6.7.4.2 How to Configure Internet Access via an External Internet Router over the WAN Port

Prerequisites

The communication system must be connected to the LAN segment of the customer LAN in which the Internet router is located via the LAN interface "WAN".

You are in the **Configure Internet Access** window.

Step by Step

- 1) Disable the **No Internet Access** check box.

- 2) Activate the radio button **TCP/IP at WAN Port** via an external router and click **OK & Next**.

- 3) If the network-specific data for the WAN interface are to be obtained from an already active DHCP server:
 - a) Select the check box **Automatic Address Configuration (with DHCP)**.
 - b) Select the **Accept IP Address of the Default Router** check box if you want this IP address to be used.
 - c) Select the check box **Accept IP Address of the DNS Server** if required.
 - d) Select the check box **Accept IP Address of the SNTP Server** if required.
- 4) If a fixed IP address is to be assigned to the WAN interface:
 - a) Clear the check box **Automatic Address Configuration (with DHCP)**.
 - b) Enter the desired **IP address** and **Netmask** of the WAN interface.
- 5) Enable the **NAT** check box.
- 6) If you also want to use Internet Telephony, select the item **Upload only** or **Upload and Download** as needed from the **Bandwidth Control for Voice Connections** drop-down list. If the download bandwidth is high and the upload bandwidth is low, bandwidth control should only be activated for the upload direction to ensure that the download bandwidth reserved for voice transmission is not unnecessarily high.
- 7) In the **Bandwidth for Downloads** and **Bandwidth for Uploads** fields, enter the bandwidth in Kbps for downloads and uploads, respectively, as provided by your Internet Service Provider.
- 8) Click on **OK & Next**.

6.7.4.3 How to Configure Internet Access via a Preconfigured ISP

Prerequisites

You are in the **Configure Internet Access** window.

Your ISP's Internet access data is available (for example, user account, password, bandwidth for upload and download, etc.).

Optional: The data for a DynDNS account is available to you (name, password, host name, domain name of the DynDNS provider)

Step by Step

- 1) Disable the **No Internet Access** check box.

- 2) Activate the radio button **DSL directly at Mainboard WAN Port** and click **OK & Next**.

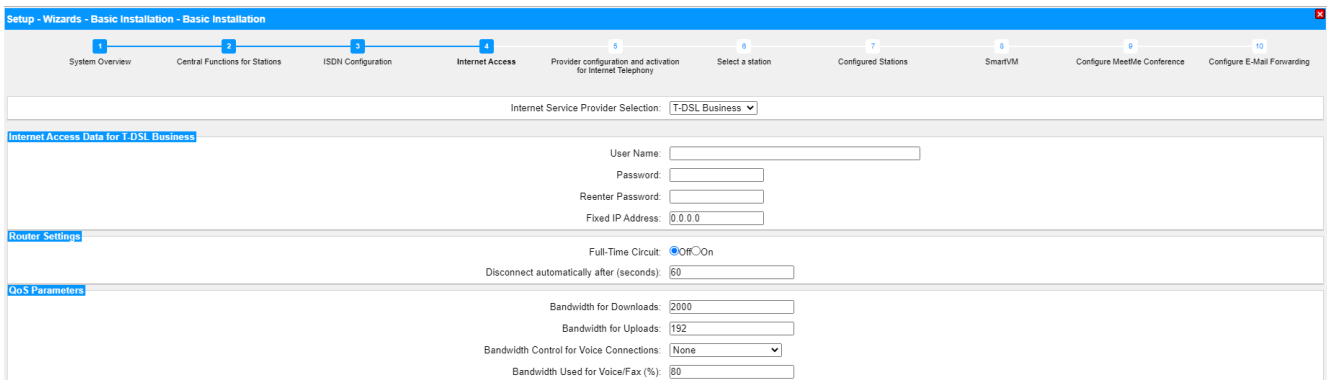

- 3) Select your ISP from the **Internet Service Provider Selection** drop-down list.
- 4) Enter the access data that you received from your ISP in the **Internet Access Data for...** area. The fields in this area are provider-specific. When entering your data, bear in mind that the input is case-sensitive!
- 5) Depending on your tariff model, select one of the following two options under **Full-Time Circuit** in the **Router Settings** area:
 - If you have a flat rate tariff model, enable the radio button **On**. In the **Forced Disconnect at (hour:min)** field, enter the time at which the Internet connection is to be interrupted (e.g., 01:30). Make sure that no data is exchanged with the Internet (e.g., software downloads or Internet telephony) during this time.
 - If you have a time-based tariff model, enable the radio button **Off**. In the **Disconnect automatically after (seconds)** field, enter the duration of inactivity after which the connection is to be dropped (e.g., 60 seconds).
- 6) Set the following values in the **QoS Parameters** area:
 - a) In the **Bandwidth for Downloads** and **Bandwidth for Uploads** fields, enter the bandwidth in Kbps for downloads and uploads, respectively, as provided by your ISP.
 - b) If you want to use Internet Telephony as well, open the drop-down list **Bandwidth Control for Voice Connections** and select the item **Upload only** or **Upload and Download**, as required. In the field **Bandwidth Used for Voice/Fax (%)**, enter how much bandwidth is to be reserved for voice and fax connections as a percentage value (default value: 80%).
- 7) Click **OK & Next**. You are taken to the **Configure DynDNS-Account** window.
- 8) If you want to use a VPN or remote access and do not have a public static IP address, you will need to have already applied for and set up a DynDNS account (at dyndns.org, for example).
 - a) If your desired DynDNS provider is included in the **Domain name** drop-down list, select it from that list (e.g., dyndns.org).
 - b) If your desired DynDNS provider is not included in the **Domain name** drop-down list, select the **User defined Domain** check box. Enter the desired DynDNS provider in the **Domain name** field and enter the update URL of the DynDNS provider in the **Update URL** field. The structure of this URL depends on the DynDNS provider. In addition,

customer-specific parameters (shown in *italics* in the example) must be supplemented.

```
http://www.anydns.info/update.php?
user=<username>&password=<pass>&host=<domain>&ip=<ipaddr>
```

- c) Enter the **User name** and the **Password** of your DynDNS account.
- d) Enter the host name assigned to you by the DynDNS provider, omitting the domain name, for instance, myhost, in the **Hostname** field. Your complete domain name would then be myhost.dyndns.org, for example.
- e) Test the DynDNS account with **Connection test**.
- f) After the test succeeds, click **OK**.
- g) Click **OK & Next**.
- 9) If you have a public static IP address or do not want to use a VPN or remote access, click **No DynDNS**.
- 10) Click **OK & Next**.

6.7.4.4 How to Configure Internet Access via the Standard ISP PPPoE

Prerequisites

You are in the **Configure Internet Access** window.

The following ISP-specific Internet access data is available to you:

Field	Description	Value from ISP
IP Parameters (only for a fixed IP address)		
Remote IP Address of the PPP Connection	IP address of your ISP's server.	
Local IP Address of the PPP Connection	IP address that was assigned to you by your ISP for Internet access.	
Authentication (via PAP or CHAP). PAP is seldom used, since the authentication is unencrypted.		
PPP User Name	User name that was assigned to you by your ISP for the PPP connection.	
PAP Authentication Mode	Authentication mode for the PPP connection over PAP: PAP Client , PAP Host or Not used .	
PAP Password	Password assigned to you by the ISP for PAP authentication	
CHAP Authentication Mode	Authentication mode for PPP connection via CHAP: CHAP Client , CHAP Host , CHAP Client and Host or Not used .	
CHAP Password	Password assigned to you by the ISP for CHAP authentication	
QoS Parameters of Interface		
Bandwidth for Downloads	Value of the full download bandwidth in Kbps provided by the ISP.	
Bandwidth for Uploads	Value of the full upload bandwidth in Kbps provided by the ISP.	

Optional: The data for a DynDNS account is available to you (name, password, host name, domain name of the DynDNS provider)

Step by Step

- 1) Disable the **No Internet Access** check box.
- 2) Activate the radio button **DSL at WAN Port directly** and click **OK & Next**.
- 3) From the **Internet Service Provider Selection** drop-down list, select the standard ISP Type **Provider PPPoE**.
- 4) The **IP parameters** check box in the **IP Parameters** area should only be enabled if the ISP requires an adjustment of these parameters. In this case, enter the values that you have received from your ISP in the **Remote IP Address of the PPP Connection**, **Local IP Address of the PPP Connection** and **Max. Data Packet Size (bytes)** fields. From the **IP Address Negotiation** drop-down list, select the item **Use configured IP address**.
- 5) Depending on your tariff model, select one of the following two options under **Full-Time Circuit** in the **Router Settings** area:
 - If you have a flat rate tariff model, enable the radio button **On**. In the **Forced Disconnect at (hour:min)** field, enter the time at which the Internet connection is to be interrupted (e.g., 01:30). Make sure that no data is exchanged with the Internet (e.g., software downloads or Internet telephony) during this time.
 - If you have a time-based tariff model, enable the radio button **Off**. In the **Disconnect automatically after (seconds)** field, enter the duration of inactivity after which the connection is to be dropped (e.g., 60 seconds).
- 6) The settings in the **Authentication** area depend on whether or not the ISP requires authentication via PPP.
 - Authentication required by ISP: Make sure that the check box **PPP Authentication** is enabled. Enter the Internet access name of the ISP as the PPP user name. The customary standard is the **CHAP Client** authentication mode.
 - Authentication not required by ISP: Make sure that the check box **PPP Authentication** is disabled.
- 7) If you want to use NAT, enable the **NAT** check box (enabled by default) in the **Address Translation** area.
- 8) Set the following values in the **QoS Parameters of Interface** area:
 - a) In the **Bandwidth for Downloads** and **Bandwidth for Uploads** fields, enter the bandwidth in Kbps for downloads and uploads, respectively, as provided by your ISP.
 - b) If you want to use Internet Telephony as well, open the drop-down list **Bandwidth Control for Voice Connections** and select the item **Upload only** or **Upload and Download**, as required. In the field **Bandwidth Used for Voice/Fax (%)**, enter how much bandwidth is to be reserved for voice and fax connections as a percentage value (default value: 80%).
- 9) Click **OK & Next**. You are taken to the **Configure DynDNS-Account** window.

- 10) If you want to use a VPN or remote access and do not have a public static IP address, you will need to have already applied for and set up a DynDNS account (at dyndns.org, for example).
 - a) If your desired DynDNS provider is included in the **Domain name** drop-down list, select it from that list (e.g., dyndns.org).
 - b) If your desired DynDNS provider is not included in the **Domain name** drop-down list, select the **User defined Domain** check box. Enter the desired DynDNS provider in the **Domain name** field and enter the update URL of the DynDNS provider in the **Update URL** field. The structure of this URL depends on the DynDNS provider. In addition, customer-specific parameters (shown in *italics* in the example) must be supplemented.

```
http://www.anydns.info/update.php?
user=<username>&password=<pass>&host=<domain>&ip=<ipaddr>
```
 - c) Enter the **User name** and the **Password** of your DynDNS account.
 - d) Enter the host name assigned to you by the DynDNS provider, omitting the domain name, for instance, myhost, in the **Hostname** field. Your complete domain name would then be myhost.dyndns.org, for example.
 - e) Test the DynDNS account with **Connection test**.
 - f) After the test succeeds, click **OK**.
 - g) Click **OK & Next**.
- 11) If you have a public static IP address or do not want to use a VPN or remote access, click **No DynDNS**.
- 12) Click **OK & Next**.

6.7.4.5 How to Configure Internet Access via a Standard ISP PPTP

Prerequisites

You are in the **Configure Internet Access** window.

The following ISP-specific Internet access data is available to you:

Field	Description	Value from ISP
IP Parameters (only for a fixed IP address)		
Remote IP Address of the PPP Connection	IP address of your ISP's server.	
Local IP Address of the PPP Connection	IP address that was assigned to you by your ISP for Internet access.	
PPTP Parameter		
Local IP Address of the Control Connection	IP address that was assigned to you by your ISP for the PPTP connection. The default value is 10.0.0.140.	
Remote IP Address of the Control Connection	IP address of your ISP's server for the PPTP connection. The default value is 10.0.0.138.	
Remote Netmask for the Control Connection	Subnet mask that was assigned to you by your ISP for the PPTP connection. The default value is 255.255.255.248.	

Field	Description	Value from ISP
Authentication (via PAP or CHAP). PAP is seldom used, since the authentication is unencrypted.		
PPP User Name	User name that was assigned to you by your ISP for the PPP connection.	
PAP Authentication Mode	Authentication mode for the PPP connection over PAP: PAP Client , PAP Host or Not used .	
PAP Password	Password assigned to you by the ISP for PAP authentication	
CHAP Authentication Mode	Authentication mode for PPP connection via CHAP: CHAP Client , CHAP Host , CHAP Client and Host or Not used .	
CHAP Password	Password assigned to you by the ISP for CHAP authentication	
QoS Parameters of Interface		
Bandwidth for Downloads	Value of the full download bandwidth in Kbps provided by the ISP.	
Bandwidth for Uploads	Value of the full upload bandwidth in Kbps provided by the ISP.	

Optional: The data for a DynDNS account is available to you (name, password, host name, domain name of the DynDNS provider)

Step by Step

- 1) Disable the **No Internet Access** check box.
- 2) Activate the radio button **DSL at WAN Port directly** and click **OK & Next**.
- 3) From the **Internet Service Provider Selection** drop-down list, select the standard ISP Type **Provider PPTP**.
- 4) The **IP parameters** check box in the **IP Parameters** area should only be enabled if the ISP requires an adjustment of these parameters. In this case, enter the values that you have received from your ISP in the **Remote IP Address of the PPP Connection**, **Local IP Address of the PPP Connection** and **Max. Data Packet Size (bytes)** fields. From the **IP Address Negotiation** drop-down list, select the item **Use configured IP address**.
- 5) Enter the values that you received from your ISP in the **PPTP Parameter** area.
- 6) If you have a time-based tariff model, select the **Short Hold** check box. In the **Short Hold Time (sec)** field, enter the duration of inactivity after which the connection is to be dropped (e.g., 60 seconds).
- 7) The settings in the **Authentication** area depend on whether or not the ISP requires authentication via PPP.
 - Authentication required by ISP: Make sure that the check box **PPP Authentication** is enabled. Enter the Internet access name of the ISP

as the PPP user name. Make the PAP and CHAP settings, as assigned to you by your ISP.

- Authentication not required by ISP: Make sure that the check box PPP Authentication is disabled.
- 8) If you want to use NAT, enable the **NAT** check box (enabled by default) in the **Address Translation** area.
 - 9) Set the following values in the **QoS Parameters of Interface** area:
 - a) In the **Bandwidth for Downloads** and **Bandwidth for Uploads** fields, enter the bandwidth in Kbps for downloads and uploads, respectively, as provided by your ISP.
 - b) If you want to use Internet Telephony as well, open the drop-down list **Bandwidth Control for Voice Connections** and select the item **Upload only** or **Upload and Download**, as required. In the field **Bandwidth Used for Voice/Fax (%)**, enter how much bandwidth is to be reserved for voice and fax connections as a percentage value (default value: 80%).
 - 10) Click **OK & Next**. You are taken to the **Configure DynDNS-Account** window.
 - 11) If you want to use a VPN or remote access and do not have a public static IP address, you will need to have already applied for and set up a DynDNS account (at dyndns.org, for example).
 - a) If your desired DynDNS provider is included in the **Domain name** drop-down list, select it from that list (e.g., dyndns.org).
 - b) If your desired DynDNS provider is not included in the **Domain name** drop-down list, select the **User defined Domain** check box. Enter the desired DynDNS provider in the **Domain name** field and enter the update URL of the DynDNS provider in the **Update URL** field. The structure of this URL depends on the DynDNS provider. In addition, customer-specific parameters (shown in *italics* in the example) must be supplemented.

```
http://www.anydns.info/update.php?
user=<username>&password=<pass>&host=<domain>&ip=<ipaddr>
```
 - c) Enter the **User name** and the **Password** of your DynDNS account.
 - d) Enter the host name assigned to you by the DynDNS provider, omitting the domain name, for instance, myhost, in the **Hostname** field. Your complete domain name would then be myhost.dyndns.org, for example.
 - e) Test the DynDNS account with **Connection test**.
 - f) After the test succeeds, click **OK**.
 - g) Click **OK & Next**.
 - 12) If you have a public static IP address or do not want to use a VPN or remote access, click **No DynDNS**.
 - 13) Click **OK & Next**.

6.7.4.6 How to Disable Internet Access

Prerequisites

You are in the **Configure Internet Access** window.

Step by Step

- 1) Leave the **No Internet Access** check box enabled.
- 2) Click on **OK & Next**.

6.7.5 Internet Telephony

The **Provider configuration and activation for Internet telephony** window is used to configure Internet telephony. You can configure predefined or new Internet Telephony Service Providers (ITSPs). You can configure one or several accounts for each ITSP. Up to 8 ITSPs may be active simultaneously.

You have the following options:

- **Configure a predefined ITSP**

You can use predefined ITSP templates. To do this, the own access data and phone numbers are entered in the template, and this is then activated.

- **Configure a new ITSP**

You can also add and activate a new ITSP.

Configuring a new ITSP is seldom required and can be very time-consuming. This option is therefore not described in the initial installation. Detailed information can be found in the chapter *Administrator Documentation, Configuring an ITSP*.

- **Disable Internet telephony**

You can disable Internet telephony.



Configuration examples can be found on the Internet at the **Unify Experts Wiki** under *OpenScape Business - SIP / ITSP Connectivity - PDF "OSBiz V2 Configuration for ITSP"*.

Assigning the ITSP Phone Numbers

- In the case of an **Internet Telephony Station Connection**, the ITSP provides individual numbers such as 70005555, 70005556, etc. These individual call numbers are then assigned manually as the internal call numbers of the subscribers.
- In the case of an **Internet telephony point-to-point connection**, the ITSP provides a call number range, e.g., (+49) 89 7007-100 to (+49) 89 7007-147. The call numbers from the range are then assigned manually as the internal call numbers of the subscribers.

These two connection types can be combined as appropriate.

Alternatively, the ITSP phone numbers can be entered as the DID call numbers of the subscriber for both connection types during the station configuration.

Internal call number	Name	DID
100	Andreas Richter	897007100
101	Susanne Mueller	897007101
102	Buddy Miller	897007102

Internal call number	Name	DID
104	Juan Martinez	70005555
105	Emilio Carrara	70005556

The ITSP call numbers thus result from the configured PABX number (e.g., country code 49) and the entered DID numbers in long format. This has advantages for the digit analysis and call management, even in an internetwork. The ITSP connection is thus DID-enabled for another node, for example.

6.7.5.1 How to Configure a Predefined ITSP

Prerequisites

You are in the **Provider configuration and activation for Internet Telephony** window.

The Internet connection is operational.

Your ITSP's Internet telephony access data is available (for example, user account, password and Internet telephony numbers).

Step by Step

- 1) Clear the **No call via Internet** check box. A country-specific list of the possible ITSPs is displayed. The list contains the predefined ITSPs for the selected country and any already created ITSPs.

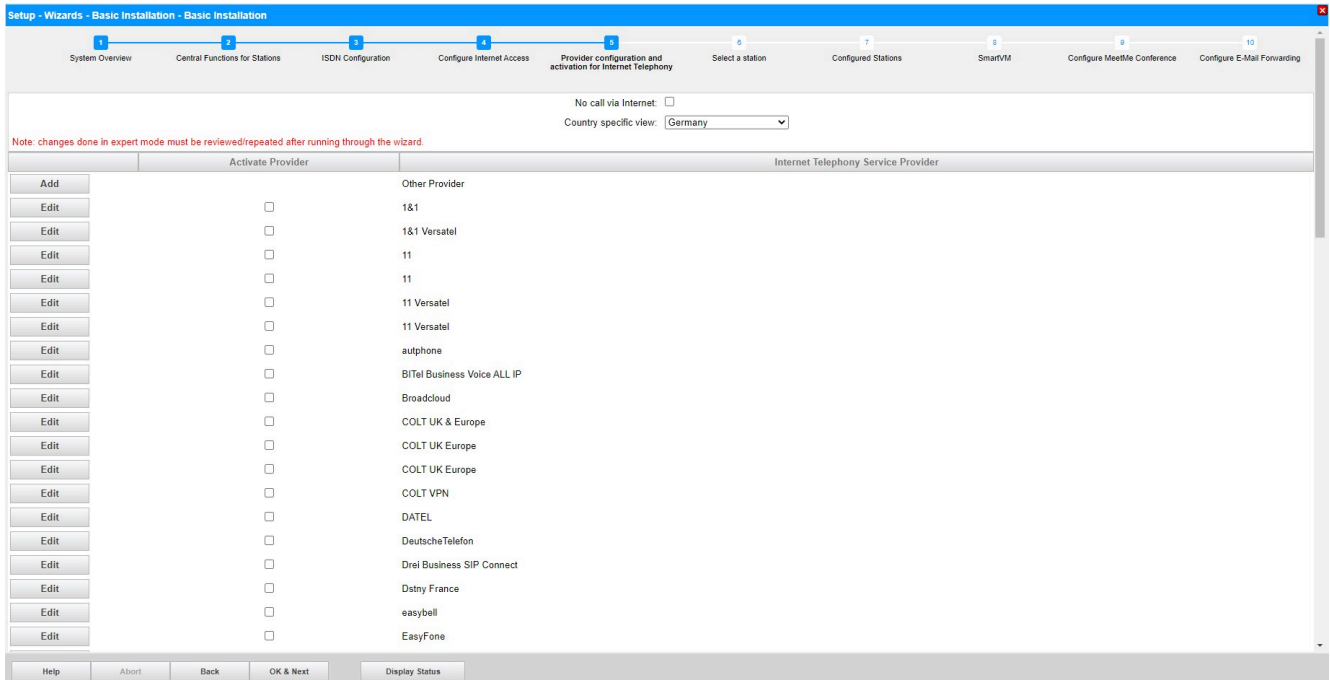

- 2) If you want to change the preset country, select the desired country from the **Country specific view** drop-down list to display the ITSPs that are available for this country.
- 3) If required, click **Display Status** to check which ITSPs have already been activated and which Internet telephony subscribers have already been

configured under each ITSP. You can activate a maximum of 8 ITSPs. Click **OK** when finished.

- 4) To configure Internet telephony stations, click **Edit** in the line associated with the relevant ITSP.
- 5) Activate the check box **Enable Provider**.
- 6) Click **OK & Next**.
- 7) Click **Add** to configure your ITSP accounts with the corresponding Internet telephony numbers. The fields that will then be displayed are provider-specific.

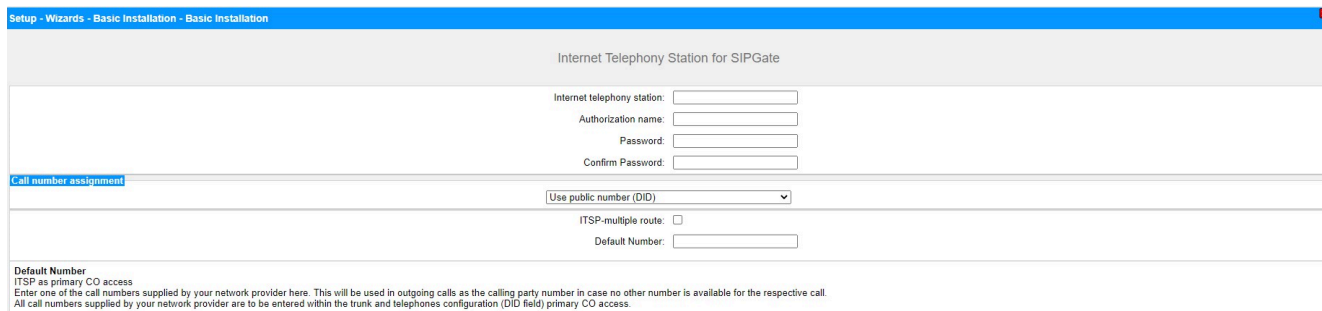

- 8) Enter the credentials for your account in the **Internet Telephony Station** field. You received this data from your ITSP. Depending on the ITSP, different designations are used for this, for example: SIP User, SIP ID, etc.
- 9) Enter the authorization name in the **Authorization name** field. You received this data from your ITSP. If you have not received any authorization name, enter the same data you entered under **Internet Telephony Station**.
- 10) Enter the password you received from the ITSP in the **New Password** and **Confirm Password** fields. Depending on the ITSP, different designations are used for this, for example: Password, SIP Password, etc.
- 11) Assignment of Internet telephony phone numbers - Option 1:
Use public number (DID): the Internet telephony phone numbers of your Internet telephony station connection or Internet telephony point-to-point connection are not entered here during the ITSP configuration, but when the configuring the stations, i.e. the telephones and subscribers (in the **DID** fields).

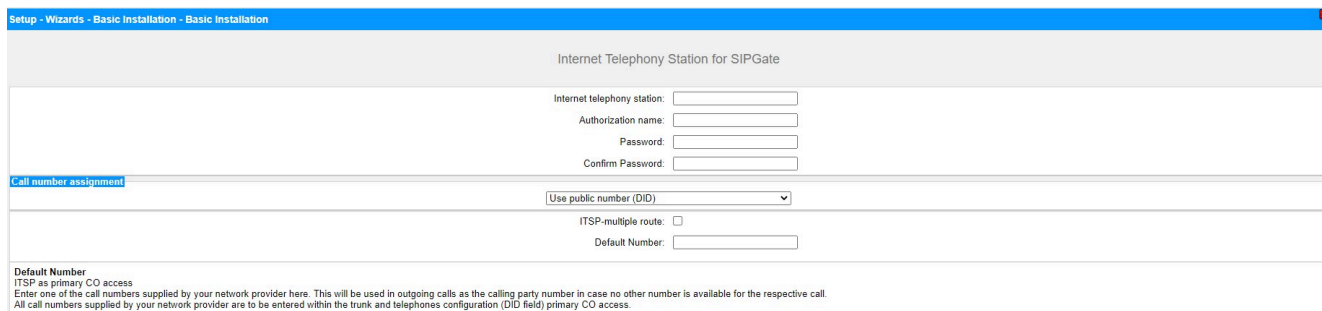

- a) Select the option field **Use public number (DID)** in the **Call number assignment** area.
- b) Under **Default Number**, enter the phone number to be used for outgoing calls to subscribers who do not have their own phone number.
- c) If your ITSP supports the "Mobile Extension (MEX)" feature, enter the MEX number provided by the ITSP (8 positions, digits only) under **MEX Number**.

12) Assignment of Internet telephony phone numbers - Option 2:

Use internal number (Callno) / Single entries: You have an Internet telephony station connection and have received individual call numbers as Internet telephony phone numbers (e.g. 70005555, 70005556,...). Then assign these single numbers to the internal call numbers of the subscribers.

Setup - Wizards - Basic Installation - Basic Installation

Internet Telephony Station for SIPGate

Internet telephony station:

Authorization name:

Password:

Confirm Password:

Call number assignment

Use public number (DID)

ITSP-multiple route:

Default Number:

Default Number
 ITSP as primary CO access
 Enter one of the call numbers supplied by your network provider here. This will be used in outgoing calls as the calling party number in case no other number is available for the respective call.
 All call numbers supplied by your network provider are to be entered within the trunk and telephones configuration (DID field) primary CO access.

- Select the option field **Use internal number (Callno) / Single entries** in the **Call number assignment** area.
- In the **Internet Telephony Phone Numbers** area, enter one of the Internet telephony phone numbers provided by the ITSP in the field next to the **Add** button and then click **Add**.
- To assign further Internet telephony numbers to the account, repeat step b).

13) Assignment of Internet telephony phone numbers - Option 3:

Use internal number (Callno) / Range entry: You have an Internet telephony point-to-point connection and have received a call number range as Internet telephony phone numbers (e.g., +49) 89 7007-100 to (+49) 89 7007-147. You then assign the call numbers from the call number range as the internal call numbers of the subscribers.

Setup - Wizards - Basic Installation - Basic Installation

Internet Telephony Station for SIPGate

Internet telephony station:

Authorization name:

Password:

Confirm Password:

Call number assignment

Use public number (DID)

ITSP-multiple route:

Default Number:

Default Number
 ITSP as primary CO access
 Enter one of the call numbers supplied by your network provider here. This will be used in outgoing calls as the calling party number in case no other number is available for the respective call.
 All call numbers supplied by your network provider are to be entered within the trunk and telephones configuration (DID field) primary CO access.

- Select the option field **Use internal number (Callno) / Range entry** in the **Call number assignment** area.
- Enter the system phone number under **System phone number (prefix)**.
- Enter the desired DID number range for the Internet telephony station in the 'from' and 'to' fields after Direct inward dialing band. The range entered by default is 100 - 147.

14) Click on OK & Next.

15) If you want to configure additional accounts and their associated Internet telephony numbers, repeat steps 7 through 14.

16) Click OK & Next. You will see an overview of which Internet telephony phone numbers are assigned to accounts.

- 17) Assign one internal station number each to every Internet telephony phone number.

This step is not required if you have selected option 1 for the assignment of the Internet telephony phone numbers. In this case, the assignment is made when the configuring the stations (i.e., the telephones and subscribers) in the **DID** field.

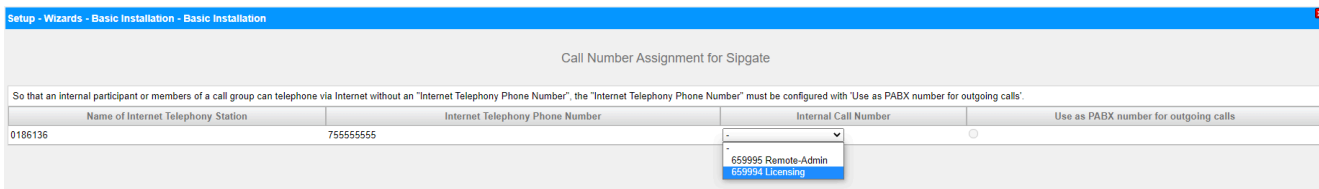

- a) To do this, select an internal call number in the appropriate line from the **Internal Call Number** drop-down list.
 - b) If subscribers without Internet telephony phone numbers or members of a call group are to be allowed to make external calls via the Internet, the radio button **Use as PABX number for outgoing calls** must be activated. The radio button can be activated for only one single Internet telephony phone number.
- 18) Click **OK & Next**. Here you see again the list of predefined and newly added ITSPs. The enabled ITSPs are identified with a check mark in the **Enable Provider** column. If you are having connection problems with already activated ITSP, you can register it again with **Restart ITSP**.
 - 19) Click **OK & Next**.
 - 20) Enter the upload speed of your Internet connection in the **Upstream up to (Kbps)** field. Please do not confuse this with the download speed!



The number of simultaneous Internet calls permitted is displayed in the **Number of Simultaneous Internet calls** field. If the voice quality deteriorates due to the network load, you will need to reduce the number.

- 21) Click **OK & Next**.
- 22) If you did not activate the full-time circuit when setting up your Internet access, you can now do this here. Without a permanent connection (full-time circuit), you cannot receive calls over the Internet. If the full-time circuit has already been set up, the fields described under a) to c) will not appear.
 - a) Enable the radio button **On** under **Full-Time Circuit**.
 - b) In the **Forced Disconnect at (hour:min)** field, enter the time at which the Internet connection is to be deactivated (e.g., 04:59).
 - c) Click **OK & Next**.

23) Enter the special numbers you want in the **Dialed digits** column.

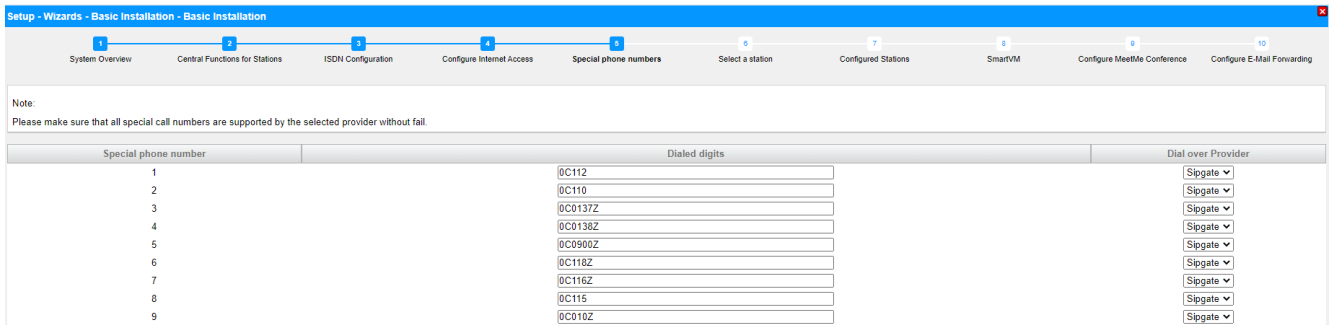

The following station number entries are valid:

- 0 to 9: allowed digits
- -: Field separator
- X: Any digit from 0 to 9
- N: Any digit from 2 to 9
- Z: One or more digits to follow up to the end of dialing
- C: Simulated dial tone (can be entered up to three times)

24) Click **OK & Next**. The status of your ITSP will be displayed.

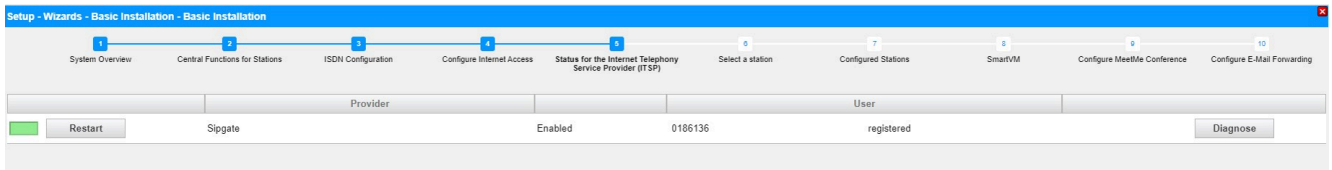

The configured ITSPs at which you are already registered are marked in green.

The configured ITSPs at which you are not yet registered are marked in orange.

25) Click **Next** followed by **Finish**.

6.7.5.2 How to Deactivate Internet Telephony

Prerequisites

You are in the **Provider configuration and activation for Internet Telephony** window.

Step by Step

- 1) Leave the **No call via Internet** check box selected.
- 2) Click **OK & Next** twice.

6.7.6 Stations

In the **Select a station - ...** window, you can configure the stations connected to the communication system.

Proceed as follows:

1) Configure analog stations

Analog stations include analog phones or analog fax devices, for example.

2) Configure U_{P0/E} stations

U_{P0/E} stations include system phones such as OpenStage 60 T.

3) Configure DECT stations

DECT stations are Cordless/DECT phones. DECT stations can only be configured if one or more Cordless base stations are connected and if the DECT phones have been registered at the base stations. Manager E is used to perform the configuration. For more detailed information on the Cordless configuration, see *Administrator Documentation, Configuring the Integrated Cordless Solution*

4) Configure the IP and SIP stations

IP and SIP stations include LAN phones or WLAN phones, for example.

6.7.6.1 How to Configure Analog Stations

Prerequisites

You are in the **Select a station - A/B Phones** window of the **Basic Installation** wizard.

A mainboard or a board with analog interfaces is available.

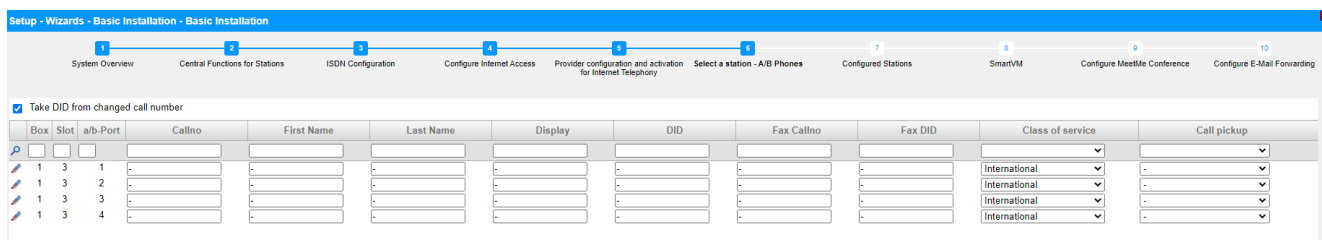

Step by Step

1) If you want a different direct inward dialing number for the station than the call number, enter a DID number for the station under **DID** in the row of the desired station:

- Only for a point-to-point connection:
Click in the desired field and type in the DID number using the keyboard. The DID number may also be identical to the internal station number.
- Only for a point-to-multipoint connection:
Select an MSN in the desired field via the drop-down list. The station can be internally reached via the internal station number 101, for example, and externally via the MSN 654321.
- For point-to-point and point-to-multipoint connections:
Select the entry **xxx - modifiable** (xxx is the internal station number) via the drop-down list in the desired field and type in the DID number using the keyboard or select an MSN from the drop-down list.

- 2) Enter the internal station number for the subscriber under **Call No** in the appropriate row of the desired subscriber. You can use the preset phone number or assign some other free number.
- 3) In the row of the desired station, under **Name**, enter a name in the format Last Name, First Name or First Name Last Name.



The name can consist of up to 16 characters, but must not include any diacritical characters such as umlauts or special characters.

- 4) If you want to set up a fax box for the subscriber (which can be used with the UC clients **myPortal for Desktop** or **myPortal for Outlook**, for example), proceed as follows:
 - a) In the row of the desired station, in the **Fax No.** field, enter the desired internal fax number at which the user can receive internal fax messages.
 - b) If you want to configure a DID number for the fax box, enter the desired external fax number under which the subscriber can receive external fax messages in the **Fax DID** field in the row of the desired subscriber.
- 5) Choose the desired Class of Service group in the row of the desired subscriber from the **Class of Service** drop-down list.
- 6) To add the subscriber to a call pickup group, select a call pickup group from the **Call pickup group** drop-down list in the row of the desired subscriber.

- 7) Make the settings described under this step only if needed:
 a) Click in the row of the desired analog station on the pencil icon **Edit**.

Setup - Wizards - Telephones / Subscribers - Analog Terminals

Change Station

Station

	Station	Fax
First Name:	<input type="text"/>	
Last Name:	<input type="text"/>	
Display: (for Subscriber):	<input type="text"/>	
Call number:	<input type="text"/>	<input type="text"/>
Direct inward dialing: (Number for Direct Inward Dialing)	<input type="text"/>	<input type="text"/>

Assign Internet Telephony Phone Number to station

Sipgate

Parameter

Device Type: -

Clip/Lin:

Access: 4SLAV 3-4

Extension Type:

Language:

Call signaling internal:
(Ringer pitch for internal calls):

Call signaling external:
(Ringer pitch for external calls):

ITSP Loc-ID:

Voicemail

UC Smart Mailbox type:

Recording:

Greeting:

Password Reset:

- b) In the **Clip/Lin** field, enter a phone number (DID number or MSN) to be displayed at the called party's extension instead of the own phone number in the case of an external call.

 This feature must be released by the network provider.

 At least one DID number should be configured. If not, the system does not take into account caller's CLIP number and the internal call number is formatted and sent as the Calling Party Number for the external call.

- c) Select the analog terminal type (Fax, for instance) from the **Extension Type** drop-down list.
- d) Select a DID number from the drop-down list in the **Direct inward dialing for Internet Telephony** area. A drop-down list is displayed for every active ITSP.

 The **DID for Internet Telephony** field is not visible if Internet telephony is not configured or if no Internet Telephony Service Provider has been activated.

- e) From the **Call signaling internal** drop-down list, select and assign one of a total of eight possible acoustic call signals for internal calls. The station then will then send the modified ringing tone to other internal stations,

thus enabling its calls to be distinguished from other internal stations (default: Ring type 1).

- f) From the **Call signaling external** drop-down list, select and assign one of a total of three possible acoustic call signals for external calls (default: Ring type 1).
 - g) Click on **OK & Next**.
 - h) Change the station flags as needed. For a description of the station flags, see *Administrator Documentation, Station > Station > Station Parameters*.
 - i) Click on **OK & Next**.
- 8) If you want to configure another analog station, click on **Store data** and repeat steps 1 through 7.
- 9) Click on **OK & Next**.

6.7.6.2 How to Configure UP0/E Stations

Prerequisites

You are in the **Select a station - UP0 Phones** window of the **Basic Installation** wizard.

A mainboard or a board with UP0 interfaces is available.

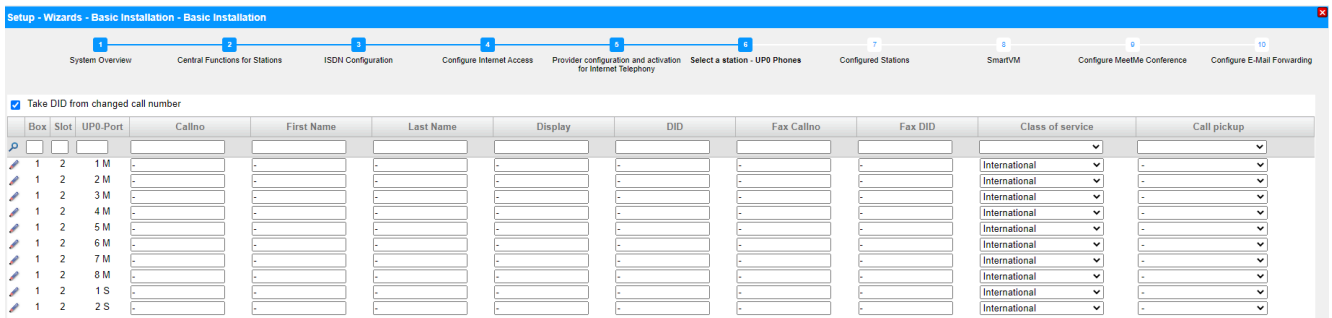

Step by Step

- 1) If you want a different direct inward dialing number for the station than the call number, enter a DID number for the station under **DID** in the row of the desired station:
 - Only for a point-to-point connection:

Click in the desired field and type in the DID number using the keyboard. The DID number may also be identical to the internal station number.
 - Only for a point-to-multipoint connection:

Select an MSN in the desired field via the drop-down list. The station can be internally reached via the internal station number 101, for example, and externally via the MSN 654321.
 - For point-to-point and point-to-multipoint connections:

Select the entry **xxx - modifiable** (xxx is the internal station number) via the drop-down list in the desired field and type in the DID number using the keyboard or select an MSN from the drop-down list.

- 2) Enter the internal station number for the subscriber under **Call No** in the appropriate row of the desired subscriber. You can use the preset phone number or assign some other free number.
- 3) In the row of the desired station, under **Name**, enter a name in the format *Last Name, First Name* or *First Name Last Name*.



The name can consist of up to 16 characters, but must not include any diacritical characters such as umlauts or special characters.

- 4) If you want to set up a fax box for the subscriber (which can be used with the UC clients **myPortal for Desktop** or **myPortal for Outlook**, for example), proceed as follows:
 - a) In the row of the desired station, in the **Fax No.** field, enter the desired internal fax number at which the user can receive internal fax messages.
 - b) If you want to configure a DID number for the fax box, enter the desired external fax number under which the subscriber can receive external fax messages in the **Fax Direct Inward Dialing** field in the row of the desired subscriber.
- 5) Choose the desired Class of Service group in the row of the desired subscriber from the **Class of Service** drop-down list.
- 6) To add the subscriber to a call pickup group, select a call pickup group from the **Call pickup group** drop-down list in the row of the desired subscriber.

- 7) Make the settings described under this step only if needed:
- a) Click in the row of the desired station on the pencil icon **Edit**.

Setup - Wizards - Telephones / Subscribers - UP0 Telephones

Change Station

Station

Station	Fax
First Name: <input type="text"/> Last Name: <input type="text"/> Display: (for Subscriber): <input type="text"/> Call number: <input type="text"/> Direct inward dialing: (Number for Direct Inward Dialing) <input type="text"/>	<input type="text"/> <input type="text"/>

Assign Internet Telephony Phone Number to station

Sipgate

Parameter

Device Type: -
 Clip/Lin:
 Language: German
 Call signaling internal:
 (Ringer pitch for internal calls) Ring type 1
 Call signaling external:
 (Ringer pitch for external calls) Ring type 1
 ITSP Loc-ID:

Voicemail

UC Smart Mailbox type: No MailBox
 Recording:
 Greeting: Greeting 1
 Password Reset:

- b) In the **Clip/Lin** field, enter a phone number (DID number or MSN) to be displayed at the called party's extension instead of the own phone number in the case of an external call.



This feature must be released by the network provider.



At least one DID number should be configured. If not, the system does not take into account caller's CLIP number and the internal call number is formatted and sent as the Calling Party Number for the external call.

- c) Select the type of TDM terminal from the **Extension Type** drop-down list.
- d) Do not change the default selection in the **Language** drop-down list. This setting has no relevance for TDM terminals.
- e) Select a DID number from the drop-down list in the **Direct inward dialing for Internet Telephony** area. A drop-down list is displayed for every active ITSP.



The **DID for Internet Telephony** field is not visible if Internet telephony is not configured or if no Internet Telephony Service Provider has been activated.

- f) From the **Call signaling internal** drop-down list, select and assign one of a total of eight possible acoustic call signals for internal calls. The station then will then send the modified ringing tone to other internal stations,

thus enabling its calls to be distinguished from other internal stations (default: Ring type 1).

- g) From the **Call signaling external** drop-down list, select and assign one of a total of three possible acoustic call signals for external calls (default: Ring type 1).
 - h) Click on **OK & Next**.
 - i) Change the station flags as needed. For a description of the station flags, see *Administrator Documentation*, **Station > Station > Station Parameters**.
 - j) Click on **OK & Next**.
- 8) If you want to configure another U_{P0/E} station, click on **Store data** and repeat steps 1 through 7.
- 9) Click on **OK & Next**.

6.7.6.3 How to Configure DECT Stations

Prerequisites

You are in the **Select a station - DECT Stations** window of the **Basic Installation** wizard.

To configure DECT stations, a base station must be connected, and the DECT phones must be logged in there. If this is not the case, skip this window. You can also configure the DECT stations later (see *Administrator Documentation*, *Configuring Stations*).

Step by Step

- 1) If you want a different direct inward dialing number for the station than the call number, enter a DID number for the station under **DID** in the row of the desired station:
 - Only for a point-to-point connection:

Click in the desired field and type in the DID number using the keyboard. The DID number may also be identical to the internal station number.
 - Only for a point-to-multipoint connection:

Select an MSN in the desired field via the drop-down list. The station can be internally reached via the internal station number 101, for example, and externally via the MSN 654321.
 - For point-to-point and point-to-multipoint connections:

Select the entry **xxx - modifiable** (xxx is the internal station number) via the drop-down list in the desired field and type in the DID number using the keyboard or select an MSN from the drop-down list.
- 2) Enter the internal station number for the subscriber under **Call No** in the appropriate row of the desired subscriber. You can use the preset phone number or assign some other free number.

- 3) If you want to set up a fax box for the subscriber (which can be used with the UC clients **myPortal for Desktop** or **myPortal for Outlook**, for example), proceed as follows:
 - a) In the row of the desired station, in the **Fax No.** field, enter the desired internal fax number at which the user can receive internal fax messages.
 - b) If you want to configure a DID number for the fax box, enter the desired external fax number under which the subscriber can receive external fax messages in the **Fax Direct Inward Dialing** field in the row of the desired subscriber.
- 4) In the row of the desired station, under **Name**, enter a name in the format `Last Name, First Name` or `First Name Last Name`.



The name can consist of up to 16 characters, but must not include any diacritical characters such as umlauts or special characters.

- 5) Choose the desired Class of Service group in the row of the desired subscriber from the **Class of Service** drop-down list.
- 6) To add the subscriber to a call pickup group, select a call pickup group from the **Call pickup group** drop-down list in the row of the desired subscriber.
- 7) If you want to change the DECT phone code (PIN), enter the new code in the row of the desired subscriber under **Mobile code**. The DECT subscribers must log on at the base station again with this code.

Initial Setup for OpenScape Business X1R

- 8) Make the settings described under this step only if needed:
 a) Click in the row of the desired station on the pencil icon **Edit**.

- b) In the **Clip/Lin** field, enter a phone number (DID number or MSN) to be displayed at the called party's extension instead of the own phone number in the case of an external call.

 This feature must be released by the network provider.

 At least one DID number should be configured. If not, the system does not take into account caller's CLIP number and the internal call number is formatted and sent as the Calling Party Number for the external call.

- c) Select the type of cordless device from the **Extension Type** drop-down list.
 d) Do not change the default selection in the **Language** drop-down list. This setting has no relevance for cordless devices.
 e) Select a DID number from the drop-down list in the **Direct inward dialing for Internet Telephony** area. A drop-down list is displayed for every active ITSP.

 The **DID for Internet Telephony** field is not visible if Internet telephony is not configured or if no Internet Telephony Service Provider has been activated.

- f) From the **Call signaling internal** drop-down list, select and assign one of a total of eight possible acoustic call signals for internal calls. The

station then will then send the modified ringing tone to other internal stations, thus enabling its calls to be distinguished from other internal stations (default: Ring type 1).

- g) From the **Call signaling external** drop-down list, select and assign one of a total of three possible acoustic call signals for external calls (default: Ring type 1).
- h) Click on **OK & Next**.
- i) Change the station flags as needed. For a description of the station flags, see *Administrator Documentation*, **Station > Station > Station Parameters**.
- j) Click on **OK & Next**.
- 9) If you want to configure another station, click on **Store Data** and repeat steps 1 through 8.
- 10) Click on **OK & Next**.

6.7.6.4 How to Configure IP and SIP Stations

Prerequisites

You are in the **Select a station - LAN Phones/WLAN Phones** window. A functional wireless LAN network is needed to operate WLAN phones.

Box	Slot	Callno	First Name	Last Name	Display	DID	Type	Fax Callno	Fax DID	Class of service	Call pickup
1	0		ppc0	x651000	x651000, ppc0	-	System Client	-	-	International	-
1	0	651001	hfa1	hfa1	hfa1, 651001	-	System Client	-	-	International	-
1	0	651002	hfa2	hfa2	hfa2, 651002	-	System Client	-	-	International	-
1	0	651003	hfa3	hfa3	hfa3, 651003	-	System Client	-	-	International	-
1	0	651004	hfa4	hfa4	hfa4, 651004	-	System Client	-	-	International	-
1	0	651005	hfa5	hfa5	hfa5, 651005	-	System Client	-	-	International	-
1	0	651007	hfa7	hfa7	hfa7, 651007	-	System Client	-	-	International	-
1	0	651009	hfa9	hfa9	hfa9, 651009	-	System Client	-	-	International	-
-	-	-	-	-	-	-	No Port	-	-	International	-
-	-	-	-	-	-	-	No Port	-	-	International	-

Step by Step

- 1) If you want a different direct inward dialing number for the station than the call number, enter a DID number for the station under **DID** in the row of the desired station:
 - Only for a point-to-point connection:

Click in the desired field and type in the DID number using the keyboard. The DID number may also be identical to the internal station number.
 - Only for a point-to-multipoint connection:

Select an MSN in the desired field via the drop-down list. The station can be internally reached via the internal station number 101, for example, and externally via the MSN 654321.
 - For point-to-point and point-to-multipoint connections:

Select the entry **xxx - modifiable** (xxx is the internal station number) via the drop-down list in the desired field and type in the DID number using the keyboard or select an MSN from the drop-down list.

- 2) Enter the internal station number for the subscriber under **Call No** in the appropriate row of the desired subscriber. You can use the preset phone number or assign some other free number.
- 3) In the row of the desired station, under **Name**, enter a name in the format `Last Name, First Name`.



The name can consist of up to 16 characters, but should not include any diacritical characters such as umlauts or special characters. The name specified here will be entered as the Last Name at the UC clients, but can be edited there.

- 4) Select the type of IP station (e.g., "System Client" or "SIP Client") from the **Type** drop-down list in the row of the desired station.
- 5) If you want to set up a fax box for the subscriber (which can be used with the UC clients **myPortal for Desktop** or **myPortal for Outlook**, for example), proceed as follows:
 - a) In the row of the desired station, in the **Fax No.** field, enter the desired internal fax number at which the user can receive internal fax messages.
 - b) If you want to configure a DID number for the fax box, enter the desired external fax number under which the subscriber can receive external fax messages in the **Fax Direct Inward Dialing** field in the row of the desired subscriber.
- 6) Choose the desired Class of Service group in the row of the desired subscriber from the **Class of Service** drop-down list.
- 7) To add the subscriber to a call pickup group, select a call pickup group from the **Call pickup group** drop-down list in the row of the desired subscriber.

- 8) Make the settings described under this step only if needed or for a SIP phone:
- Click in the row of the desired station on the pencil icon **Edit**.

- For SIP phones: If the SIP phone is to be operated in conjunction with a dual-mode mobile phone, enter the dialout prefix followed by the telephone number of the mobile phone (e.g., **0016012345678**) in the **Mobility** area under **Mobile phone number**. In addition, select this SIP client from the **Web Feature ID** drop-down list. (see *Administrator Documentation, Dual-Mode Telephony*).
- In the **Clip/Lin** field, enter a phone number (DID number or MSN) to be displayed at the called party's extension instead of the own phone number in the case of an external call.



This feature must be released by the network provider.



At least one DID number should be configured. If not, the system does not take into account caller's CLIP number and the internal call number is formatted and sent as the Calling Party Number for the external call.

- Select the language for the menu controls on the phone from the **Language** drop-down list.
- From the **Call signaling internal** drop-down list, select and assign one of a total of eight possible acoustic call signals for internal calls. The station then will then send the modified ringing tone to other internal

- stations, thus enabling its calls to be distinguished from other internal stations (default: Ring type 1).
- f) From the **Call signaling external** drop-down list, select and assign one of a total of three possible acoustic call signals for external calls (default: Ring type 1).
 - g) Only for SIP phones: Enable the **Authentication active** check box.
 - h) Only for SIP phones: Enter the authentication password in the **Password** and **Confirm password** fields.
 - i) Only for SIP phones: Enter the user ID for the authentication in the **SIP User ID / Username** field.
 - j) Only for SIP phones: Enter the associated zone for the authentication in the **Realm** field.
 - k) Click on **OK & Next**.
 - l) Change the station flags as needed. For a description of the station flags, see *Administrator Documentation*, **Station > Station > Station Parameters**.
 - m) Click on **OK & Next**.
- 9) If you want to configure another IP station, click on **Store data** and repeat steps 1 through 8.
 - 10) Click on **OK & Next**. A list of all configured stations appears. This list is effectively a dial plan.
 - 11) If required, click **Print** to print out the data of the configured stations.
 - 12) Then click **OK & Next**.

6.7.7 Configuring UC Suite

You can perform the automatic configuration of the UC solution UC Suite in the **Automatic Configuration of the Application Suite** window.



This window appears only if **Package with UC Suite** was selected during the application selection in the **Initial Installation** wizard.

6.7.7.1 How to Configure the UC Suite

Prerequisites

You are in the **Automatic Configuration of Application Suite** window.

Setup - Wizards - Basic Installation - Basic Installation

1
System Overview

2
Central Functions for Stations

3
ISDN Configuration

4
Configure Internet Access

5
Provider configuration and activation for Internet Telephony

6
Select a station

7
Configured Stations

8
Automatic Configuration of Application Suite

SIPQ-Interconnection 1: -
SIPQ-Interconnection 2: -

Application Suite is not configured.

Please press 'Ok & Next' for skipping this page or press 'Execute function' to proceed with the automatic Application Suite configuration.

Note that by pressing 'Execute function' SIPQ-Interconnection 1 will be overwritten and assigned to Application Suite profile.

Step by Step

Click on **Execute function**. The UC Suite is configured automatically. Once the progress bar shows 100%, click on **OK & Next**.

6.7.8 Configuring UC Smart Mailboxes

If you are using the UC solution UC Smart, you can perform the automatic configuration of the UC Smart voicemail boxes (Smart VM, Smart VoiceMail) in the **Automatic Configuration of Smart VM** window.



This window appears only if **Package with UC Smart** was selected during the application selection in the **Initial Installation** wizard.

6.7.8.1 How to Configure UC Smart Voicemail Boxes

Prerequisites

You are in the **Smart VM** window.

Setup - Wizards - Basic Installation - Basic Installation

1
System Overview

2
Central Functions for Stations

3
ISDN Configuration

4
Configure Internet Access

5
Provider configuration and activation
for Internet Telephony

6
Select a station

7
Configured Stations

8
SmartVM

- The automatic Smart VM configuration is an initial configuration and generates the necessary data to setup voicemail boxes or can be used to recover existing mailboxes with default settings. If there are already existing voicemail or autoattendant mailboxes, then all mailbox data will be deleted irrevocably! This affects also mailboxes created by the xml-import. If the corresponding intercept position call number (Smart VM) is configured, a mailbox is created for that intercept position. If the corresponding autoattendant call number (Smart VM) is configured, a mailbox is created for that autoattendant. A mailbox is created for each of the first 99 stations. MeetMe station needs to be already configured in order for a MeetMe mailbox to be created. The second group/hunt group, used for Smart VM, is recovered with default data. The third group/hunt group, used for autoattendant, is recovered with default data.
- Press "Execute function" to proceed with Smart VM configuration or press "Ok & Next" for skipping this page.

Step by Step

- 1) If the UC Smart voicemail boxes are not to be used, click on **OK & Next**. The configuration of the voicemail boxes will be skipped.
- 2) If the UC Smart voicemail boxes are to be used, click on **Execute function**. Voicemail boxes are then automatically configured for the first 100 subscribers. Once the progress bar shows 100%, click on **OK & Next**.



Existing UC Smart or UC Smart AutoAttendant voicemail boxes are irrevocably deleted in the process.

6.7.9 Conference Server Settings

The **MeetMe Conference** settings window can be used to define the call numbers and the dial-in numbers for conferences.

6.7.9.1 How to Edit the Conference Server Settings

Prerequisites

You are in the **Configure MeetMe Conference** window.

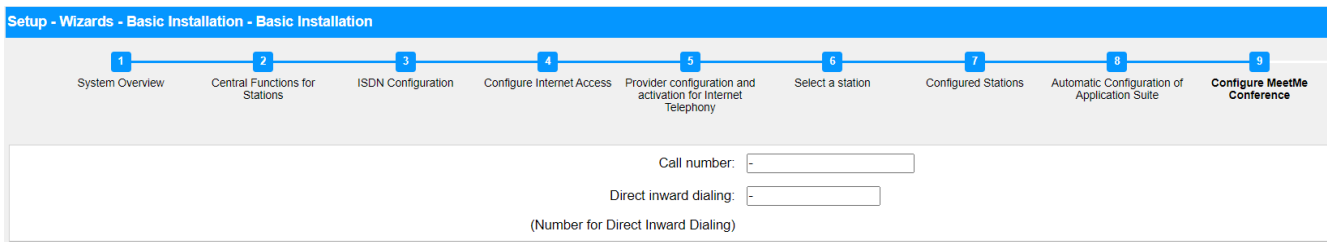

Step by Step

- 1) Enter a phone number for the conference in the **Call Number** field.
- 2) Enter the dial-in number for the conference (conference DID) with which subscribers can dial into an existing conference in the **Direct inward dialing** field.
- 3) Click on **OK & Next**.

6.7.10 E-mail Delivery (Optional)

You can configure the delivery of e-mails in the **Configure E-Mail Forwarding** window. These e-mails notify users of voicemail and fax messages and administrators of system messages.

You have the following options:

- Configuring the Sending of E-mails

You can specify an external E-mail server via which the e-mails are to be sent by OpenScape Business. Voicemails, fax messages and internal system messages can then be sent via this E-mail server to one or several different configurable e-mail addresses.



Entering the e-mail server is important if an e-mail with a link to the installation file(s) is to be automatically sent to the users of the UC Suite.

6.7.10.1 How to Configure the Sending of E-mails

Prerequisites

If the external E-mail server has been configured to use basic authentication, make sure an e-mail account with a password exists with an e-mail provider, and you know the access data for this account.

If the external E-mail server has been configured to use modern authentication (Microsoft OAuth 2.0 token-based authorization), as in the case of Exchange Online, make sure that:

- An application with the required permissions has been registered in Microsoft Azure Active Directory (Azure AD) for your OpenScape Business system to send emails.
- You know the Application (client) ID and the Directory (tenant) ID of the registered application.

Ask your Azure AD administrator to provide these values, if required.

- The email address that will appear as the sender of the emails belongs to the same Azure AD or tenant as the registered application.

You are in the **Configure E-Mail Forwarding** window of the **Basic Installation** wizard.

Setup - Wizards - Basic Installation - Basic Installation

1 System Overview 2 Central Functions for Stations 3 ISDN Configuration 4 Configure Internet Access 5 Provider configuration and activation for Internet Telephony 6 Select a station 7 Configured Stations 8 Automatic Configuration of Application Suite 9 Configure MeetMe Conference 10 **Configure E-Mail Forwarding**

Server Information

Outgoing Mail Server (SMTP)

Outgoing mail server port

This server requires an encrypted connection (TLS/SSL)

Logon Information

Authentication method

User Name

Password

Confirm Password

User Information (Sender)

E-Mail Address

All change notification recipients

E-Mail Address 1

E-Mail Address 2

Emergency Notifications Recipient

Emergency Recipient

Help Abort Back OK & Next Check e-mail forwarding

Figure 19: E-mail forwarding options when basic authentication method is selected

Step by Step

- 1) Enter the **Outgoing mail server (SMTP)** for the e-mail server to be used for sending e-mails. Ask your e-mail provider for the outgoing mail server if required.



Make sure that the name of the outgoing mail server can be resolved. If not, you must start the e-mail sending function via **Service Center > E-mail Forwarding** and then enter the IP address of the outgoing mail server instead of its name.

- 2) Enter the **Outgoing mail server port** for the server port to be used for sending e-mails. Ask your e-mail provider for the outgoing mail server if required.
- 3) If a secure connection is required, enable the **This server requires an encrypted connection (TLS/SSL)** check box. If required, check with your e-mail provider whether this option needs to be enabled.
- 4) If the external E-mail server has been configured to use basic authentication, proceed as follows:
 - a) From the **Authentication method** drop-down list, select **Basic**.
 - b) Enter the **User Name** of the e-mail account.
 - c) Enter the **Password** for the e-mail account and repeat it in the **Confirm Password** field.
- 5) If the external E-mail server has been configured to use modern authentication, proceed as follows:
 - a) From the **Authentication method** drop-down list, select **Microsoft OAuth 2.0**.
 - b) Enter the Application (client) ID obtained from the Microsoft Azure portal in the **Application ID** field.
 - c) Enter the Directory (tenant) ID obtained from the Microsoft Azure portal in the **Tenant** field.
- 6) Enter the **E-mail Address** that will appear as the sender of the emails.
- 7) Enter the **E-mail Address 1** to get a notification email when ALI tolerance has been used. You may also enter a second email address in the **E-mail Address 2** field.
- 8) In the **Emergency Recipient** field, enter the e-mail address of an on-site security officer to which an e-mail is sent when an emergency number is dialed.

The subject of the e-mail will be "New emergency call". The call number and the name of the caller, if configured, are included in the e-mail which are retrieved from the database of the system.

- 9) If you have selected **Microsoft OAuth 2.0** as authentication method, proceed as follows:
 - a) Click on **OK & Next**.
 - b) Wait for an authorization link and user code to appear.
The authorization code expires after some minutes.
 - c) Open the authorization link and enter the user code on the pop-up.
 - d) Sign in with the email address you have entered in step 6 on page 114 (**E-mail Address**).
The email address must be in the same Azure AD or tenant as the registered application.
 - e) After successful authentication, the pop-up displays a message as below:

```
You have signed in to the <application-name> on your device. You may now close this window..
```
 - f) Close the pop-up and return to WBM. If the authentication was successful, you will see the message `The authentication was successful!`.
- 10) If you want to check the entered e-mail settings, proceed as follows:
 - a) Click on **Check e-mail forwarding**.
 - b) Under **Send to e-mail address**, enter the e-mail address of any e-mail box that you can access. The test e-mail will be sent to that e-mail address.
 - c) Under **Subject in the e-mail**, enter a descriptive text so that you can identify the e-mail in your e-mail inbox.
 - d) Click on **Send Test E-mail**. The e-mail settings are verified, and the e-mail is sent to the specified e-mail address.
 - e) Check whether the e-mail has arrived in your e-mail inbox.
 - f) If the e-mail was sent correctly, click **Back** and proceed to the next step.
 - g) If the e-mail delivery failed, click **Back** and correct your e-mail settings.
- 11) Click on **OK & Next** followed by **Finish**. The basic installation is finished. Before you perform the backup mentioned in the wizard, you should activate the licenses.

6.8 Closing Activities

After the initial installation and the basic installation with the WBM have been completed, some important settings must still be made for the operation of OpenScape Business.

Proceed as follows:

1) Activate and assign licenses

The licenses procured with OpenScape Business must be activated within a period of 30 days. The time period begins the next time you log on to the WBM. After this time period expires, the communication system will only operate in restricted mode. Once the licenses have been activated successfully, they must be assigned to the stations and lines. In a standalone system, system-wide features are enabled automatically upon activation.

2) Provision the UC Smart client for installation (only for UC Smart)

3) How to Provision the UC Suite Clients for Installation (for UC Suite only)

The UC Suite clients are part of UC Suite. The installation files for the UC Client are accessible via the WBM and can be made available to the IP stations automatically or manually.

In addition, the administrator has the option of performing a silent installation. The silent installation/uninstallation is a command-line based method to automatically install, uninstall or modify UC Suite PC clients on a PC without requiring any further user inputs. For more information, see *Administrator Documentation, Silent Installation/Uninstallation for UC Suite PC Clients*.

4) Go through the product-specific security checklist with the customer and document any deviations.

5) Perform a data backup

All previous changes to OpenScape Business must be backed up. The backup can be stored as a backup set on a USB storage device or in the internal network.

6.8.1 How to Activate and Assign the Licenses

Prerequisites

You are logged on to the WBM with the **Advanced** profile.

You know the LAC (License Authorization Code) for releasing the license and have a user ID and password for accessing the license server.

You need Internet access to connect to the license server.

Step by Step

- 1) Activate license online:
 - a) In the navigation bar, click on **Setup**.
 - b) In the navigation tree, click **Wizards > Basic Installation**.
 - c) Click on **Edit** to start the **Licensing** wizard.

Setup - Wizards - Basic Installation - Licensing

Activate License Online

Licenses with Locking ID: 00-1a-e8-5d-37-81

License Authorization Code (LAC)

I have the user name and password for the License Server and want to log on.

User name

Password

Note: The response from the License Server can take up to 90 seconds !

Please enter the [registration data](#) first. Only then can the license file be activated.

- d) Enter the appropriate LAC in the **License Authorization Code (LAC)** field.
- e) Select the check box **I have the user name and password for the License Server and want to log on**.
- f) Enter the **User Name** and **Password** for logging into the License Server.
- g) Click on **OK & Next**. The connection to the license server is established, and the licenses are released.

- 2) Assign licenses to stations:
 - a) Click on **License Management** in the navigation bar.
 - b) In the navigation tree, navigate to the desired type of subscriber under **Local User Licenses > ...**. You will be shown a list of all subscribers of the selected subscriber type.
 - c) In the row of the desired subscriber, select the check box in the **User license** column (first column with check boxes).

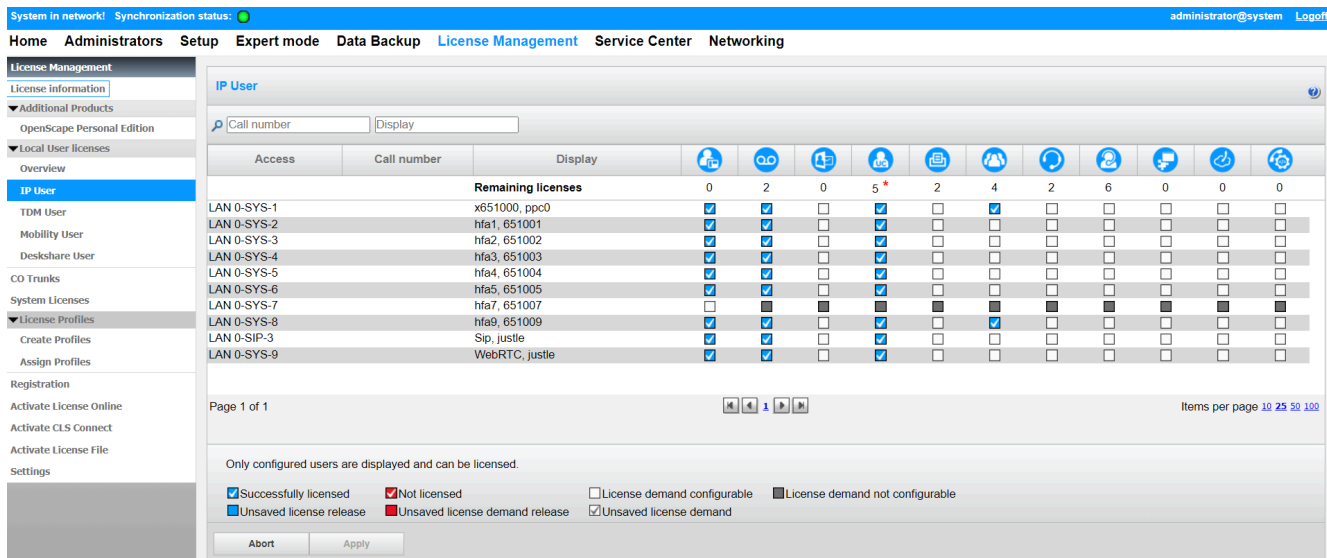

- d) Activate the user-oriented licenses in the row of the desired subscriber by selecting the appropriate check boxes.



User-oriented licenses can be assigned to a subscriber only if a station license (user license) was assigned to the subscriber earlier (step c).

- e) Click on **OK & Next**. A check is performed to determine whether there are enough licenses for your assignment.

If sufficient licenses are available, the licensing of the subscriber is completed.
- f) If licenses are missing, the errors are indicated by displaying a check box shaded in red. Correct these errors and repeat step e.

- 3) Assign licenses to trunks:
 - a) For SIP trunks: In the **License demand for number of simultaneous Internet calls in this node** area, enter the number of Internet calls that can be conducted simultaneously via an ITSP.
 - b) Click on **OK & Next**.



The number of licensed SIP trunks must not exceed the number of trunk licenses purchased.

6.8.2 How to Provision the UC Smart Client for Installation

Prerequisites

You are logged on to the WBM with the **Advanced** profile.

The hardware and software for using UC myPortal @work are available.



Licenses are required to use the UC Smart client myPortal @work.

Step by Step

- 1) Click on **Service Center** in the navigation bar.
- 2) Click on **Software** in the navigation tree.
- 3) Click on the Download icon of **myPortal @work** and save the installation file on a shared network drive.
- 4) Send the two installation files to the users of myPortal @work.
- 5) Alternatively, you can also send the users of myPortal @work the link with which they can access the installation file:

```
https://<IP address of the communication system>/
management/downloads/myPortalAtWorkSetup.exe
```

6.8.3 How to Provision the UC Suite Clients for Installation

Prerequisites

You are logged on to the WBM with the **Advanced** profile.

The hardware and software for using the UC Suite are available.



Licenses are required to use the UC Suite clients.

Step by Step

- 1) To enable the installation files to be provided automatically to a station, make sure that the following steps have been performed:
 - a) The e-mail addresses of the stations and the associated subscriber data must have either been already imported via an XML file or entered later under **Setup > UC Suite > User Directory**.
 - b) An e-mail server must have been specified.



You can also enter an E-mail server later under **Service Center > E-mail Forwarding**.

All subscribers whose e-mail addresses are known receive an e-mail with a link to the installation directory of the UC clients and Getting Started Instructions. The installation folder also includes a Readme file with information on installing the software on client PCs.

- 2) If the required steps for automatic notification are not fulfilled, you can also make the installation files available manually. To do this, proceed as follows:
 - a) Click on **Service Center** in the navigation bar.
 - b) Click on **Software** in the navigation tree.
 - c) Click on the desired UC client and save the zipped installation file on a shared network drive.
 - d) Click in the navigation tree on **Documents** and select **User Guide** from the drop-down list.
 - e) Click on the documentation of the desired UC client and save the documentation file on a shared network drive.
 - f) Send the zipped installation file and the documentation file to the users of the UC clients by e-mail or inform the users about the storage location of these files.
 - g) The zip file with the installation files also includes a Readme file. Notify the users that the installation of the UC clients must be performed in accordance with the installation notes in the Readme file.
- 3) Alternatively, you can also send the UC users links through which they can directly access the installation files of the UC clients.
 - a) Click on **Service Center** in the navigation bar.
 - b) Click on **Software** in the navigation tree.
 - c) Click on the **Show Application Links** button. You will be presented with multiple links, depending on the used operating system and the desired UC client. For example:

```
https://<IP address of the communication system>/  
management/downloads/install-common.zip
```

6.8.4 How to Perform a Data Backup

Prerequisites

You are logged on to the WBM with the **Advanced** profile.

For a backup to a USB storage device (USB stick or USB hard disk), the USB device must be connected to the USB server port.



For more information on backing up data, see *Administrator Documentation, Immediate Backup*.

Step by Step

- 1) Click on **Backup and Restore** in the navigation bar.
- 2) In the navigation tree, click **Backup - Immediate**.
- 3) Enter a comment for the backup set in the **Comment** field in the **Name** area so that the backup set can be easily identified if needed later for a restore. Avoid the use of diacritical characters such as umlauts and special characters in your input.
- 4) Activate the target drive on which the backup set is to be saved in the **Devices** area.
- 5) Click on **OK & Next**. The progress of the backup process is displayed in a separate window.

- 6) The backup was successful if the message **Backup completed successfully!** appears. Click on **Finish**.
- 7) If you are using a USB stick as the backup medium, wait until the LED of the USB stick stops blinking. This ensures that the backup has been successfully saved on the USB stick. You can then safely remove the USB stick.
- 8) This completes the initial startup with WBM. Exit the WBM by right-clicking the **Logout** link on the top right of the screen and then close the window.



If a new software version for the communication system is available, you will be notified about this on the home page of the WBM, provided the Internet connection was set up correctly. If a new software version is available, perform an update (see *Administrator Documentation, Updating the Communication System*).

6.9 Commissioning of IP Phones

The commissioning of IP phones can be facilitated by the existence of a DHCP server that supplies an IP phone with important (network-specific) data that is needed to log into the communication system.

Network-Specific Data

In order to log into the communication system, an IP phone requires some network-specific data. This data can be stored in the DHCP server or be entered directly at the IP phone. The advantage of a DHCP server is that all connected IP phones are automatically supplied with the relevant data.

The following data is required by the IP phone:

- IP address of the communication system
- IP address of DLS server

In addition, the IP phone needs its own call number. This must be entered manually when logging in at the phone.

Registration of SIP Phones

For security reasons, it is recommended that SIP phones register at the communication system. To do this, the registration information on the IP phone and the communication system must match.

The following data is required for the login:

- SIP user ID
- SIP password
- SIP realm (optional)

Use a non-trivial SIP password that complies with the following rules:

- At least 8 characters
- At least one uppercase letter (A - Z)
- At least one lowercase letter (a - z)
- At least one digit (0-9)
- At least one special character

Use a SIP user ID that does not include the phone number.

 More information on configuring SIP telephones can be found at http://wiki.unify.com/wiki/SIP_devices_configuration_examples.

Using the Internal DHCP Server

If the internal DHCP server of the communication system is used, the network-specific data will already be stored there. In order to enable an IP phone to register at the communication system, only the specified call number must be entered at the IP phone. In the case of SIP phones, the SIP registration data at the SIP phone and at the communication system must match.

Using an External DHCP Server with Network-specific Data

If an external DHCP server is used, the network-specific data must be stored there. In order to enable an IP phone to register at the communication system, only the specified call number must be entered at the IP phone. In the case of SIP phones, the SIP registration data at the SIP phone and at the communication system must match.

Using an External DHCP Server without Network-specific Data

If an external DHCP server in which the network-specific data cannot be stored is used, this must be entered at the IP phone. To enable an IP phone to register at the communication system, the defined call number and IP address of the communication system must be entered at the phone, and the settings for the Deployment Service may need to be changed. In the case of SIP phones, the SIP registration data at the SIP phone and at the communication system must match.

6.9.1 How to Configure an IP Phone

Prerequisites

The IP phone is connected to the internal network and operational.

 The sample configuration described here uses an OpenStage 40/60/80 IP system telephone. The same settings must also be made for any other IP phone. For more information, refer to the manual supplied with your IP phone.

Step by Step

- 1) To reach the administration mode of the IP system telephone, press the appropriate key for the Settings/Applications menu on the phone.
- 2) Scroll through the Settings options until Admin and confirm this with the OK key.
- 3) Enter administrator password (123456 by default) and confirm your selection with the OK key.

- 4) If you are using the DHCP server of the communication system in the internal network, skip the next step.
- 5) If you are not using the DHCP server of the communication system in the internal network, you will need to enter the IP addresses of the Deployment Server (DLS) and the communication system so that the software of the IP system telephone can be updated automatically. This applies only to IP system telephones. Proceed as follows:
 - a) Scroll to `Network` and confirm your selection with the OK key.
 - b) Scroll to `Update service (DLS)` and confirm your selection with the OK key.
 - c) Scroll to `DLS address` and confirm your selection with the OK key.
 - d) Specify the IP address of the communication system (`192.168.1.2` by default) as the Deployment Server and confirm your entry with the OK key.
 - e) Scroll to `Save & Exit` and confirm your selection with the OK key.
 - f) Scroll to `IPv4 configuration` and confirm your selection with the OK key.
 - g) Scroll to `Route (default)` and confirm your selection with the OK key.
 - h) Specify the IP address of the communication system (`192.168.1.2` by default) and confirm your entry with the OK key.
 - i) Scroll to `Save & Exit` and confirm your selection with the OK key.
 - j) Navigate one menu level back with the Back key.
- 6) Specify the call number of the phone:
 - a) Scroll to `System` and confirm your selection with the OK key.
 - b) Scroll to `Identity` and confirm your selection with the OK key.
 - c) Scroll to `Terminal number` and confirm your selection with the OK key.
 - d) Enter the set phone number (e.g., `120`) and confirm your selection with the OK key.
 - e) Scroll to `Save & Exit` and confirm your selection with the OK key.
- 7) Navigate one menu level back with the Back key.
- 8) If the system telephone needs to be restarted due to the changes made, the menu item `Restart` will appear in the `Admin` menu. Confirm the `Restart` with the OK key and then also confirm `Yes` with the OK key. The system telephone performs a reboot and logs in to the communication system.

6.9.2 How to Configure a SIP Phone

Prerequisites

The SIP phone is connected to the customer LAN and operational.



The configuration described here uses an OpenStage 40/60/80 SIP system telephone as an example. The same settings must also be made for another SIP phone. For more information, refer to the manual supplied with your SIP phone.

Step by Step

- 1) To reach the administration mode of the SIP system telephone, press the appropriate key for the Settings/Applications menu on the phone.
- 2) Scroll through the `Settings` options until `Administrator (Admin)` and confirm this with the OK key.
- 3) Enter administrator password (`123456` by default) and confirm your selection with the OK key.
- 4) If you are using the DHCP server of the communication system in the internal network, skip the next step.
- 5) If you are not using the DHCP server of the communication system in the internal network, you will need to enter the IP addresses of the Deployment Server (DLS) and the communication system so that the software of the SIP system telephone can be updated automatically. This applies only to SIP system telephones. Proceed as follows:
 - a) Scroll to `Network` and confirm your selection with the OK key.
 - b) Scroll to `Update service (DLS)` and confirm your selection with the OK key.
 - c) Scroll to `DLS address` and confirm your selection with the OK key.
 - d) Specify the IP address of the communication system (`192.168.1.2` by default) as the Deployment Server and confirm your entry with the OK key.
 - e) Scroll to `Save & Exit` and confirm your selection with the OK key.
 - f) Scroll to `IPv4 configuration` and confirm your selection with the OK key.
 - g) Scroll to `Route (default)` and confirm your selection with the OK key.
 - h) Specify the IP address of the communication system (`192.168.1.2` by default) and confirm your entry with the OK key.
 - i) Scroll to `Save & Exit` and confirm your selection with the OK key.
 - j) Navigate one menu level back with the Back key.
- 6) Specify the SNTP time settings:
 - a) Scroll to `Date and time` and confirm your selection with the OK key.
 - b) Scroll to `Time source` and confirm your selection with the OK key.
 - c) Scroll to `SNTP IP address` and confirm your selection with the OK key.
 - d) Specify the IP address of the communication system (`192.168.1.2` by default) and confirm your entry with the OK key.
 - e) Scroll to `Timezone offset` and confirm your selection with the OK key.
 - f) Enter the deviation between the local time and UTC (Universal Time Coordinated) in hours (Germany: `1`) and confirm this with the OK button.
 - g) Scroll to `Save & Exit` and confirm your selection with the OK key.
 - h) Navigate one menu level back with the Back key.

- 7) Specify the call number of the phone:
 - a) Scroll to `System` and confirm your selection with the OK key.
 - b) Scroll to `Identity` and confirm your selection with the OK key.
 - c) Scroll to `Terminal number` and confirm your selection with the OK key.
 - d) Enter the set phone number (e.g., 120) and confirm your selection with the OK key.
 - e) Scroll to `Save & Exit` and confirm your selection with the OK key.
- 8) Specify the SIP authentication data:
 - a) Scroll to `Registration` and confirm your selection with the OK key.
 - b) Scroll to `SIP Session` and confirm your selection with the OK key.
 - c) Note the `Realm`, or enter a new realm (e.g., OSBIZ-SIP), if necessary.
 - d) Note the `User ID`, or enter a new user ID (e.g., SIP-120), if necessary.
 - e) Specify a `Password` for registering at the SIP server.
 - f) Scroll to `Save & Exit` and confirm your selection with the OK key.
- 9) Use the Back key to go back to the `Admin` menu.
- 10) If the system telephone needs to be restarted due to the changes made, the menu item `Restart` will appear in the `Admin` menu. Confirm the `Restart` with the OK key and then also confirm `Yes` with the OK key. The system telephone performs a reboot and logs in to the communication system.

6.10 Reasons for System Restart

6.10.1 System restart for OpenScape Business X1R

OpenScape Business system may restart for the following reasons:

Reset Actions via Reset Button and Service Center

Action Reset Button	Event Log Entry	Customer Trace - Event Viewer
Reset	Reset button restart action	System restarts because of RESET BUTTON RESTART action.
Power off	Reset button shutdown action	System restarts because of RESET BUTTON SHUTDOWN action.
Reload	Reset button reload action	System restarts because of RESET BUTTON RELOAD action.

Action Admin Portal	Event Log Entry	Customer Trace - Event Viewer
Reset	Admin/Portal restart	System restarts because of ADMIN/PORTAL RESTART.
Power off	Admin/Portal shutdown	System restarts because of ADMIN/PORTAL SHUTDOWN.
Reload	Admin/Portal reload	System restarts because of ADMIN/PORTAL RELOAD.

Software Update and Configuration Restarts

Action	Event Log Entry	Customer Trace - Event Viewer
Software Upgrade Success	Software update Admin/Portal – Restart ¹	System restart because of SOFTWARE UPDATE. System restart because of ADMIN/PORTAL RESTART. ¹
Software Upgrade Failure Switchback Reset	Software switchback	System restart because of SOFTWARE UPDATE. System restart because of ADMIN/PORTAL RESTART.
Software Configuration and Administration restarts	Admin/Software Delayed Restart	System restart because of ADMIN or SOFTWARE RESET.

Application and system failure restarts

Action	Event Log Entry	Customer Trace - Event Viewer
Application Failures Reset By Observer	Process Failure	System restart because of PROCESS FAILURE
System and OS Failures Power failure Linux Kernel Failure	Power down or watch dog or kernel oops	System restart because of POWER DOWN or WATCH DOG or KERNEL OOPS

¹ Software update initiates two system restarts, second restart triggered automatically by admin/portal.

Error Reasons

Action	Event Log Entry	Customer Trace - Event Viewer
Undefined Entry ²	Error! no reason available!	System restart because of < Error Missing Entry >
Unknown Reason ³	Unknown reason	System restart because of < Unknown Reason >

² System reset and power off initiated by console commands (requires root access).

³ The reason of restart is available, but it's undefined. Error should be reported.

7 Integrated Cordless Solution

OpenScape Business Cordless is integrated cordless solution for the operation of cordless telephones (DECT phones) via the communication system. With the connected DECT phones, the HFA features of OpenScape Business can be used.

7.1 System Overview

The integrated Cordless solution enables the direct connection (DECT Light) of base stations to the communication system.

In the integrated cordless solution, the DECT phones are internal, system-specific stations as opposed to separate DECT systems, which are connected via standard interfaces.

The connection of OpenScape Business base stations for the operation of DECT phones can be implemented via:

- Direct connection to the U_{P0/E} interfaces of the OCCSBR and OCCSAR central control board of OpenScape Business X1R.

The Cordless radio technology corresponds to the DECT (Digital Enhanced Cordless Telecommunications) Standard. The entire radio area administered by the system is made up of base stations, which together form either a complete network of overlapping radio cells or individual radio "islands". The size of a radio cell is dependent on the local/structural factors.

The integrated Cordless solution supports GAP-enabled mobile telephones from third-party manufacturers. The full scope of HFA services can, however, only be used with approved DECT phones.



OpenScape Business X1R does not support multi-SLC.



The description of the configuration can be found in the OpenScape Business Administrator Documentation (*Administrator Documentation, Configuring the Integrated Cordless Solution*).

CMAe Option

By using the CMAe subboard on the mainboards the ADPCM conversion and echo cancellation functions (48 channels for CMAe) are made available. Up to four calls can be conducted per base station. Up to seven base stations can be connected to the U_{P0/E} interfaces of the mainboards OCCSBR and OCCSAR.

If no CMA is installed, a maximum of two calls can be conducted per base station. In this case, the ADPCM conversion is performed directly by the DECT base station.



In case no CMAe is installed, no echo handling functions are available.

7.1.1 System Configuration

Up to 7 base stations can be connected, and up to 16 DECT phones can be used.

The following table shows the maximum possible system configuration of the integrated Cordless solution.

⚠ WARNING Risk of electric shock through contact with live wires!

Use separate ground wires to provide protective grounding for the system boxes of your communication system as well as all main distribution frames and patch panels before connecting the base stations.

NOTICE The base stations BS4 (S30807-U5491-X), BS3/1 (S30807-H5482-X), BS3/3 (S30807-H5485-X) and BS3/S (X30807-X5482-X100) are being phased out and can no longer be ordered. However, they can still be connected to OpenScape Business X1R.

In the event of a failure, the current base stations should be used.

OpenScape Business	Clock Module	Max. number of BaseStation BS when connected via 1xUP0	Ports/ Simultaneous calls per BS	Max. number of registered devices	Max. number of simultaneous calls
X1R	–	7	1/2	16	14
	CMAe	7	1/4	16	16

7.1.2 Traffic capacity

The traffic capacity inside different radio cells (for example, in offices, warehouses or garage areas) varies according to the subscribers.

The following tables provide reference values for the traffic capacity of individual base stations. These values apply to a single radio cell not having overlapping ranges with other radio cells (without overload handling).

A distinction is made here, depending on whether the connection of the base station occurs via one $U_{P0/E}$ interface (= four simultaneously available voice channels), two $U_{P0/E}$ interfaces (= eight simultaneously available voice channels) or three $U_{P0/E}$ interfaces (= 12 simultaneously available voice channels) of a Cordless board.

Table 7: Traffic capacity of single base stations with 50 mErl per subscriber

	Connecting the base station					
	1 x U _{P0/E}		2 x U _{P0/E}		3 x U _{P0/E}	
Grade Of Service (GOS)	0.1 %	1 %	0.1 %	1 %	0.1 %	1 %
Number of stations per base station	11	16	42	62	84	118
Traffic capacity	0.55 erlangs	0.8 erlangs	2.1 erlangs	3.1 erlangs	4.2 erlangs	5.9 erlangs

Table 8: Traffic capacity of single base stations with 100 mErl per subscriber

	Connecting the base station					
	1 x U _{P0/E}		2 x U _{P0/E}		3 x U _{P0/E}	
Grade Of Service (GOS)	0.1 %	1 %	0,1 %	1 %	0,1 %	1 %
Number of stations per base station	7	8	21	31	42	59
Traffic capacity	0.7 erlangs	0.8 erlangs	2.1 erlangs	3.1 erlangs	4.2 erlangs	5.9 erlangs

Table 9: Traffic capacity of single base stations with 200 mErl per subscriber

	Connecting the base station					
	1 x U _{P0/E}		2 x U _{P0/E}		3 x U _{P0/E}	
Grade Of Service (GOS)	0.1 %	1 %	0.1 %	1 %	0.1 %	1 %
Number of stations per base station	4	5	10	15	21	29
Traffic capacity	(0.8 erlangs)	1 erlangs	2.1 erlangs	3.1 erlangs	4.2 erlangs	5.9 erlangs

7.1.3 Grade Of Service (GOS)

The Grade of Service indicates the availability (i.e., successful setup) and loss (i.e., the termination) of call connections in cordless solutions.

To calculate the capacity limits, the following assumptions are made: 1 % GOS per radio interface and 0.1 % on the PCM highway of the communication system and on the networking connections. A GOS of 1 % for availability means that an average of one call out of 100 cannot be made. For a call from handset

to handset, 1 % GoS per radio interface means that an average of two calls out of 100 (2 %) cannot be made.

Radio field quality and the number of available channels are crucial elements for setting up a call and for call breakdowns in cordless connections. Poor radio field quality results in high breakdown rates, low availability, and poor voice quality. This may occur if the physical structure of buildings (a lot of metal, machinery, tin, etc.) causes inhomogeneous fields and reflections. In such cases, a GOS of 1% or 2% cannot be achieved. The interference described can also occur when using other DECT devices (such as cordless headsets or cordless phones).

7.1.4 Single-Cell Mode

Single-cell mode allows up to 8 DECT telephones that are registered together to a base station and are in one call group to ring simultaneously. Only one B channel is occupied in the process. The DECT phone that answers the call uses this B channel. The single-cell mode is only supported for DECT Light. Only one base station (BS3/S, BS4 or BS5) may be connected to a U_{P0/E} interface of the OCCM/OCCMR mainboard.

By contrast, in the multi-cell mode (when more than one base station is connected), the number of DECT phones that can ring simultaneously is equal to the number of free B-channels. This restriction does not apply in single-cell mode (when only one base station is connected), since only one B-channel is used.

NOTICE

The system automatically switches from single-cell mode to multi-cell mode if an additional BS5 base station is connected or if a BS4 or BS3/S base station is replaced with a BS5 base station and more BS5 base stations are additionally connected. In these cases, the first BS5 base station automatically restarts and switches to multi-cell mode.

The switch from multi-cell mode back to single-cell mode requires a manually initiated system restart after the additional base stations have been removed.

7.2 Testing a Cordless Solution

To ensure trouble-free operation of a cordless solution, a number of different tests must be conducted after the initial startup. The test results must be documented in the building/site plan.

7.2.1 Checking the Base Stations and the Radio Coverage

After the initial startup of a cordless solution, a test of the base stations and the radio coverage (area coverage) must be conducted.

NOTICE

The following information refers to measurements performed with DECT phones. The resulting measurement values are not very precise and thus represent only a rough estimate. In addition, different values may be recorded on each DECT phone even though the ambient conditions are identical.

If greater accuracy is required, the measurements should be performed with a special service tool for cordless systems (such as the HCS Locator Pro, for example).

Base Station Test

The purpose of this test is to check the functions of all base stations.

- Test the radio link (synchronicity) between the DECT phone and the base station
- Measure the following values:

- RSSI (Received Signal Strength Indication)

Field strength of the radio signals received from a base station, normalized to a maximum of 100.

If the RSSI value is < 50 , the radio connection to the base station is no longer guaranteed. An acceptable RSSI value is > 50 (> -60 dBm).

- FRAQ (Frame Quality)

Transmission quality in %

Values of 95 % to 100 % are satisfactory (for short periods, values of 90 % to 94 % are non-critical). Sustained values below 95% result in transmission errors.

Test the radio coverage (area coverage)

The purpose of this test is to check whether the necessary field strength and the transmission quality is attained throughout the entire radio network.

Using a DECT phone (with the measuring mode enabled), move around the radio coverage area and check whether an RSSI value > 50 (> -60 dBm) and a FRAQ value $> 95\%$ are achieved throughout the area. Areas in building corners or behind metal structures, in particular, should be checked carefully (by verifying the RSSI values several times).

Activating the range warning feature is useful in this context. Exceeding the range limit (border zone of the radio range) is then signaled by a warning tone.

In these border zones of the radio range, the radio connection to the base station may be lost.

Presentation of the Measurement Results

The following value is an example of the display of a measurement result on a DECT phone of type OpenStage SL4 Professional (Gigaset SL4 Professional):

087-7-02-20-100

- 087 = Field strength (RSSI) of the radio signals received from the base station (maximum value = 100)
- 7 = Frequency (value range 0 to 9)
- 02 = Time slot of the receiving channel on which the measurement was performed (value range 0 to 11).
- 20 = Identification of the base station via the Radio Fixed Part Identity RFPI as a hexadecimal number (20 corresponds to decimal 32)
- 100 = Transmission quality (FRAQ) in %

7.2.1.1 Testing Base Stations



The following information refers to the operation of a DECT phone of the type OpenStage SL4 Professional (Gigaset SL4 Professional).

The default language for measuring mode is English.

Step by Step

- 1) Move with the DECT phone close to a base station to be tested.
- 2) Holding the DECT phone directly below, beside or above the base station to be tested, turn it off and on again.
 - If a radio link (synchronicity) with the base station exists, this will be indicated in the display as *Station 1*, for example.
Continue with step 3.
 - If there is no radio link (synchronicity) with the base station, this will be indicated by a flashing display (for example, *Station 1* will be shown flashing).
Repeat step 2 with another DECT telephone. If no radio link can be established with this DECT phone as well, replace the base station.
- 3) Turn off the DECT phone.
- 4) Press the keys **1**, **4** and **7** simultaneously together with **Hang up** key in order to activate the service mode.
Service appears on the display.
- 5) Enter the code **76200** to bring up the service menu.
- 6) In the service menu, navigate to the item **Measuring mode** and confirm the selection with the **OK** key.
This enables the measuring mode.
- 7) In the service menu, navigate to the item **Measuring time** and confirm the selection with the **OK** key.
- 8) Set the desired measuring time using the control keys (< = to reduce the measuring time, and > = to increase the measuring time).
The displayed value range for the measuring time is between 06 and 16. This corresponds to a measuring cycle between 1 and 2.5 seconds.
The recommended value of 16, which corresponds to a measuring cycle of 2.5 seconds.
- 9) Confirm the set values by pressing the **Save** key.

- 10) Turn off the DECT phone.
- 11) Turn on the DECT phone again.

After switching on the DECT phone, the measurement values are shown on the display and updated on the basis of the set measuring cycle.

For example: 087-7-02-20-100 (see [Checking the Base Stations and the Radio Coverage](#))

- If the required measurement values (RSSI value > 50 (> - 60 dBm), FRAQ > 95%) are achieved, continue with step 12.
- If the required measurement values (RSSI value > 50 (> - 60 dBm), FRAQ > 95%) are not achieved, repeat steps 3 through 11 with another DECT phone.

If this DECT phone does not reach the required measurement values either, replace the base station.

- 12) Repeat the testing for all other base stations.

7.2.1.2 Check the Radio Coverage



The following information refers to the operation of a DECT phone of the type OpenStage SL4 Professional (Gigaset SL4 Professional).
The default language for the measuring mode is English.

Step by Step

- 1) Turn off the DECT phone.
- 2) Press the keys **1**, **4** and **7** simultaneously together with **Hang up** key in order to activate the service mode.
Service appears on the display.
- 3) Enter the code **76200** to bring up the service menu.
- 4) In the service menu, navigate to the item **Measuring mode** and confirm the selection with the **OK** key.
This enables the measuring mode.
- 5) In the service menu, navigate to the item **Measuring time** and confirm the selection with the **OK** key.
- 6) Set the desired measuring time using the control keys (< = to reduce the measuring time, and > = to increase the measuring time).
The displayed value range for the measuring time is between 06 and 16.
This corresponds to a measuring cycle between 1 and 2.5 seconds.
The recommended value of 16, which corresponds to a measuring cycle of 2.5 seconds.
- 7) Confirm the set values by pressing the **Save** key.
- 8) Turn off the DECT phone.

- 9) Turn on the DECT phone again.

After switching on the DECT phone, the measurement values are shown on the display and updated on the basis of the set measuring cycle.

Example: 087-7-02-20-100

- 10) With a DECT phone, move around the area in question and determine whether an RSSI value > 50 (> -60 dBm) and a FRAQ value > 95 % are reached throughout the area.

Pay particular attention to areas in building corners and behind metal structures (by measuring the RSSI values several times).



Enable the "Range warning" feature (Tones menu). Exceeding the range limit (border zone of the radio range) is then signaled by a warning tone.

In these radio area border zones, the radio connection to the base station may be lost.

- 11) Draw the coverage area with an RSSI value > 50 in the building/site plan.

7.2.2 Documentation of the Test Results

The test results of the radio coverage (area coverage) must be entered or marked in the building/site plan.

The following data should be documented:

- Installation locations of the base stations and their Radio Fixed Part Identity RFPI
- Radio range with an RSSI value > 50

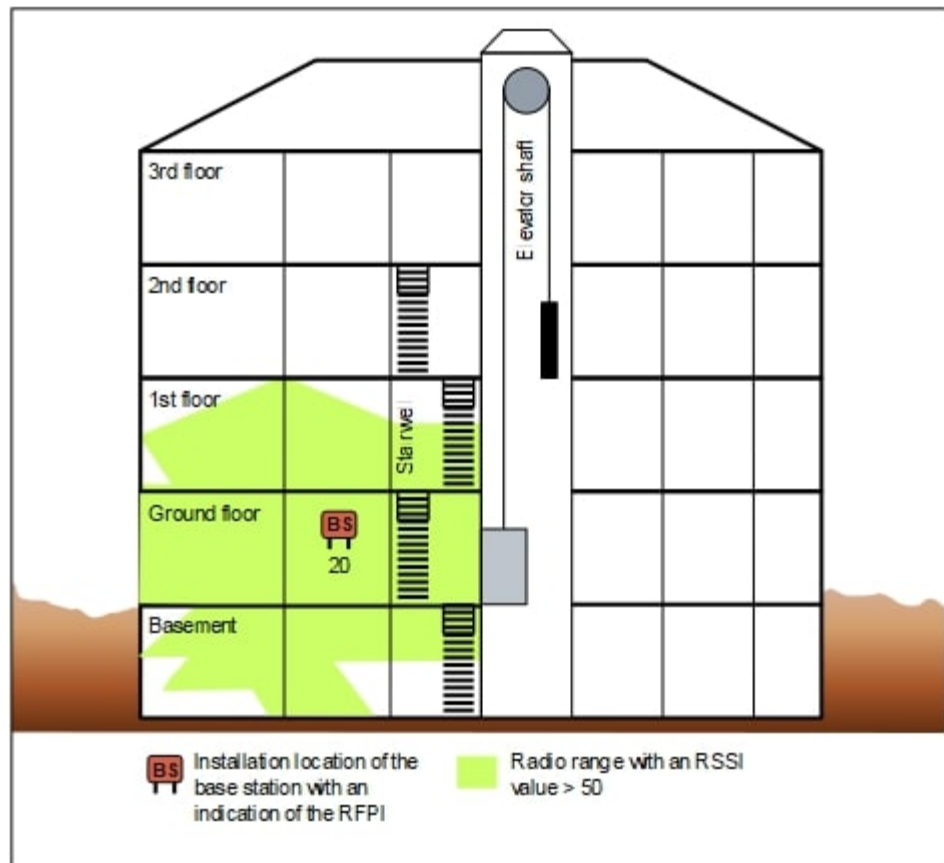

Figure 20: Example for the Documentation of Test Results in a Building Plan

7.3 Troubleshooting

Here you will learn how to troubleshoot and correct potential disruptions and errors.

Synchronization symbol on the display of DECT phones

- No synchronization to base station: Flashing display of Station XY
 - DECT phone not logged on?
Remedy: Log in the DECT phone.
 - If the DECT phone is logged into multiple systems, is it switched to the correct system? Is automatic system selection activated?
Remedy: Check the registration of the DECT phone. If necessary, log in the DECT phone again.
 - Base station defective?
Remedy: [Check base stations.](#)

- Synchronization to the base station: Steady display of `Station XY`, but no action is possible.
 - An error tone can be heard when the line key is pressed: Temporary overload status (all the base station speech paths are busy).
Remedy: Wait, and try again.
 - DECT phone has not completed the location request (contact of the DECT phone to the communication system) successfully.
Remedy: Repeat location request by switching off the DECT phone and then switching it on again.
 - DECT phone is no longer registered.
Remedy: Log in the DECT phone again.

DECT telephone

- Problems when logging in:
 - Are the "home cordless board" and at least one base station (within range of the DECT phone) as well as the Cordless board to which this base station is connected operational (is the green LED lit on the Cordless board?)
 - If the DECT phone is to be registered via a "current-location cordless board", the extension connections must be operational.

A connection to the extension connection port must be tested by using a corded phone. If the call succeeds, the connection is OK. Otherwise, an error has occurred, and the configuration of the extension connection must be checked.
 - Is a sufficiently accurate clock pulse supply ensured by the communication system?

If the station display on a registered DECT phone is not permanently active, this could indicate a bad clock pulse supply. For example, if `Base Search` occasionally appears in the idle state.
- No visual user prompts:
 - When logging in the DECT phone, was the line key pressed before the "Silent Call" arrived?

Remedy: Log in the DECT phone again and wait for Silent Call. If the error persists, the phone involved is an unauthorized DECT phone.

Silent Call means a short automatic call (on some devices this is like 2 rings). If you are registering an inactive call number (which has not been used before, it looks black at WBM and gray in KDS) then the registration is completed with one silent call. If you are registering an active call number that has been used before (looks green at WBM and KDS) then the registration is completed with two silent calls.

8 Appendix

The appendix contains reference information such as hardware capacity limits, the interface ranges for subscriber lines, the maximum cable lengths for trunk connections and direct CorNet NQ/QSIG wiring and the country-specific ring frequencies for analog subscriber line modules. In addition, it also includes information on the power requirements of the boards and connectable telephones, key modules, adapters and base stations.

8.1 Interface Ranges for Subscriber Lines

The following table lists the maximum possible interface ranges for subscriber lines when using cables of type J-Y (ST) 2x2x0.6 (0.6 mm conductor diameter).

Table 10: Interface Ranges for Subscriber Lines (for J-Y (ST) 2x2x0.6, (0.6 mm conductor diameter)

Interface	Range	Loop resistance
a/b	< 2000 m	520 ohms
U _{P0/E} : master	< 1000 m	230 ohms
U _{P0/E} : master-slave configuration	< 100 m	23 ohms

